



CARBITTOOL

Product Catalogue

Router Bits and Accessories

STATEMENT OF QUALITY



Over 40 years of manufacturing focus with an ongoing commitment to introducing new technology.

Carbitool has a long standing reputation for excellence in the manufacture of carbide tools for the woodworking, cabinetry, joinery, furniture, timber and panel industries. Using the latest CNC (computerised numerical controlled) technology, Carbitool is committed to ongoing product development and quality improvement.

With a comprehensive range of woodworking tools including; router bits, saw blades, planer blades, drills, countersinks for timber and a range of engineering products such as slot drills, carbide endmills and burs, vee bits, cemented carbide rod, strips and disposable inserts, hss metal cutting saws and saw sharpening supplies.

Carbitool was founded by Neil Hamilton in Victoria, Australia in 1974. Since then with the demand for high quality tools increasing exponentially, Carbitool expanded and acquired four Melbourne and Sydney manufacturing businesses to meet market expectation.

In 2018, Carbitool became a division of Sutton Tools, an Australian family owned company, manufacturing world class cutting tools for over 100 years, forming part of its global business serving industry, trades, hobbyists and retailers worldwide.



CARBIDE GRINDING

Australian Made ANCA MX7 Linear and MX7 grinding machines with automatic loaders ensure Carbitool router bits are manufactured to exact tolerances with superior cutting edge sharpness.

DIAMOND GRINDING

Diamond grinding machines are used to manufacture PCD and CBN tools, that have high cutting edge accuracy, surface finish, as well as accurate repeatability. These high specifications are a requirement for the automotive, aerospace, woodworking and general engineering industries.

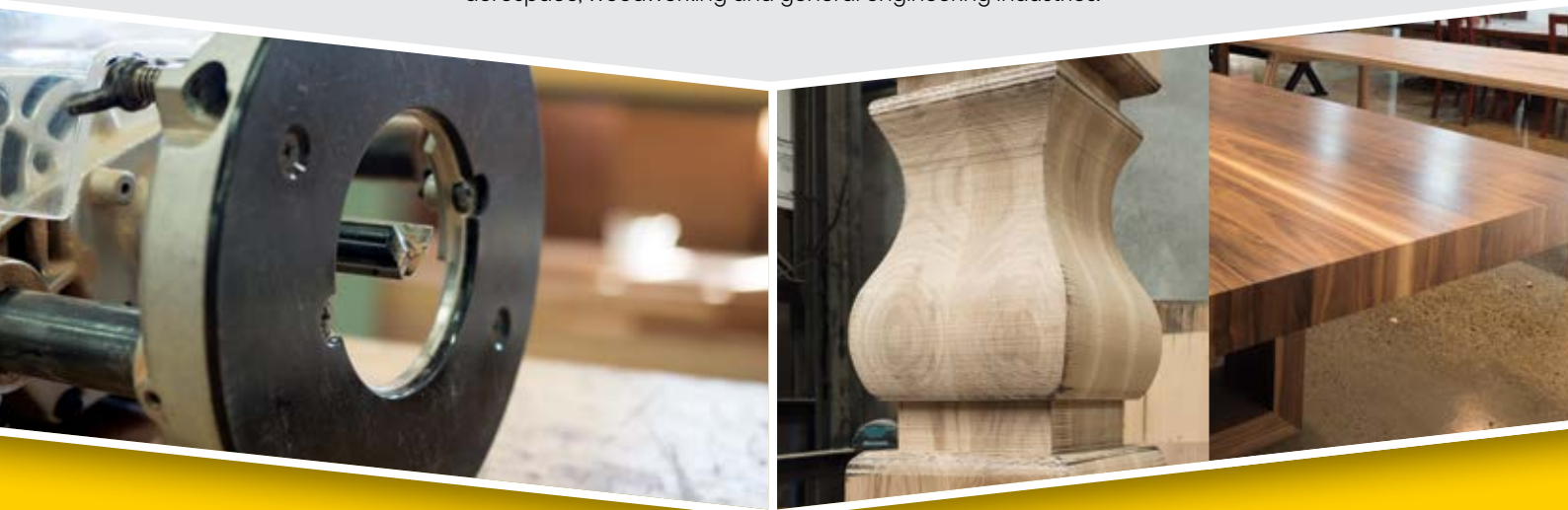

ABBREVIATIONS AND DESCRIPTIONS

- Prefix H = High Speed Steel
- Prefix T = Carbide Tipped or Solid Carbide
- Suffix A = Carbide Tip on Nose (Pilot Panel Bits)
- Suffix B = Ball Bearing Guide
- Suffix E/C = End Cutting
- Suffix M = Metric Size

Note: The last two numerical digits denote cutting size ie.

Metric T 216 M = 16mm Dia.
Imperial T 224 = 24/32 = 3/4" Dia.

- Suffix S = Single Flute
- Suffix 3/8 = 3/8" Diameter Shank
- Suffix 1/2 = 1/2" Diameter Shank
- Suffix 10mm = 10 mm Diameter Shank
- Suffix 5/16 = 5/16" Diameter Shank

- Affix X = Long Series Router Bits. Not guaranteed against breakage
- Affix XX = Extra Long Series Router Bits. Not guaranteed against breakage

- A = Cutting Width
- B = Flute Length
- C = Overall Length. On router bits with bearings. Includes bearing and screw.

- E = Pilot Width or Bearing Width
- ID = Inside Diameter
- T = Wood Thickness
- G = Depth of Cut
- Bevel = Bevel
- R, R1, R2 = Radius / Radii

Product Group		Discount Group		A		B		C	
R577		Z0906							
Part No.	inch	mm	inch	mm	inch	mm	inch	mm	
HIGH SPEED STEEL									
HT12	17/32	13.5	3/8	9.5	1-3/8	35			

Product Group		Discount Group		A		B		C	
R578		Z0904							
Part No.	inch	mm	inch	mm	inch	mm	inch	mm	
CARBIDE TIPPED									
T112	45/64	18	0.365	9.2	1-3/4	44.4			
T128	1-15/64	31.3	5/8	15.9	2	50.8			
T128 1/2									
T128 1/2									

Part No.	inch	mm	inch	mm	inch	mm
T 502 B	5/8	15.9	5/16	7.9	1-7/8	47
T 502 MB	21/32	16.7	11/32	8.7	17/8	47
T 504 B	3/4	19	1/2	12.7	2	50.8
T 504 MB	13/16	20.6	7/16	11.1	2	50.8
T 506 B	7/8	22.2	15/32	12	2	50.8
T 506 B 1/2	7/8	22.2	15/32	12	2-1/2	63.5
T 505 MB	7/8	22.5	15/32	12	2	50.8
T 506 MB	31/32	24.7	33/64	13	2-3/4	69.9
T 508 B	1	25.4	1/2	12.7	2	50.8
T 508 B 1/2	1	25.4	1/2	12.7	2-1/2	63.5
T 510 B	1-1/8	28.6	1/2	12.7	2	50.8
T 510 B 1/2	1-1/8	28.6	1/2	12.7	2-5/8	66.7
T 512 B	1-1/4	31.8	5/8	15.9	2-1/4	57.1

Product Group		Discount Group		A		B		C		R Radius		Shank		Barcode
R613		Z0904												
Part No.	inch	mm	inch	mm	inch	mm	inch	mm	inch	mm	inch	mm	inch	mm
T 502 B	5/8	15.9	5/16	7.9	1-7/8	47	1/16	1.6	1/4	-	9314350006096			
T 502 MB	21/32	16.7	11/32	8.7	17/8	47	5/64	2	1/4	-	9314350014671			
T 504 B	3/4	19	1/2	12.7	2	50.8	1/8	3.2	1/4	-	9314350006102			
T 504 MB	13/16	20.6	7/16	11.1	2	50.8	1/8	3.2	1/4	-	9314350006102			
T 506 B	7/8	22.2	15/32	12	2	50.8	3/8	9.5	1/2	-	9314350006102			
T 506 B 1/2	7/8	22.2	15/32	12	2-1/2	63.5	3/8	9.5	1/2	-	9314350006102			
T 505 MB	7/8	22.5	15/32	12	2	50.8	5/8	15.9	1/2	-	9314350006102			
T 506 MB	31/32	24.7	33/64	13	2-3/4	69.9	5/8	15.9	1/2	-	9314350006102			
T 508 B	1	25.4	1/2	12.7	2	50.8	5/8	15.9	1/2	-	9314350006102			
T 508 B 1/2	1	25.4	1/2	12.7	2-1/2	63.5	5/8	15.9	1/2	-	9314350006102			
T 510 B	1-1/8	28.6	1/2	12.7	2	50.8	5/8	15.9	1/2	-	9314350006102			
T 510 B 1/2	1-1/8	28.6	1/2	12.7	2-5/8	66.7	5/8	15.9	1/2	-	9314350006102			
T 512 B	1-1/4	31.8	5/8	15.9	2-1/4	57.1	5/8	15.9	1/2	-	9314350006102			
T 512 B 1/2	1-1/4	31.8	5/8	15.9	2-1/4	57.1	5/8	15.9	1/2	-	9314350006102			
T 510 MB 1/2	1-9/32	32	2-1/2	63.5	1/4	6.35	1/4	6.35	1/2	-	9314350006102			
T 512 MB 1/2	1-7/16	36	2-1/2	63.5	1/4	6.35	1/4	6.35	1/2	-	9314350006102			
T 516 B	1-1/2	38	3/4	19	2-1/2	63.5	3/8	9.5	1/2	-	9314350006102			
T 516 B 1/2	1-1/2	38	3/4	19	2-1/2	63.5	3/8	9.5	1/2	-	9314350006102			
T 520 B 1/2	1-3/4	44.5	7/8	22.2	3-1/4	82	5/8	15.9	1/2	-	9314350006102			
T 524 B 1/2	2	50.8	1	25.4	3-1/4	82	3/4	19	1/2	-	9314350006102			
T 528 B 1/2	2-1/4	57.1	1-1/4	31.8	3-5/8	92	1	25.4	1/2	-	9314350006102			
T 532 B 1/2	2-1/2	63.5	1-1/4	31.8	3-5/8	92	1	25.4	1/2	-	9314350006102			
T 540 B 1/2	3	76.2	1-1/2	38	3-3/4	95	1-1/4	31.8	1/2	-	9314350006102			

EDGE FORMING BITS

ROUTER BITS

2 Flute - Rounding Over Bit with Pilot - Carbide Tipped

• Gives extra smooth chatter free cuts due to precise tool geometry
• Can be converted to a beading bit by using bearing TB B

Product Group		Discount Group		A		B		C		R Radius		Shank		Barcode
R613		Z0904												
Part No.	inch	mm	inch	mm	inch	mm	inch	mm	inch	mm	inch	mm	inch	mm
T502 B	5/8	15.9	5/16	7.9	1-7/8	47	1/16	1.6	1/4	-	9314350006096			
T502 MB	21/32	16.7	11/32	8.7	17/8	47	5/64	2	1/4	-	9314350014671			
T504 B	3/4	19	1/2	12.7	2	50.8	1/8	3.2	1/4	-	9314350006102			
T504 MB	13/16	20.6	7/16	11.1	2	50.8	1/8	3.2	1/4	-	9314350006102			
T506 B	7/8	22.2	15/32	12	2	50.8	3/8	9.5	1/2	-	9314350006102			
T506 B 1/2	7/8	22.2	15/32	12	2-1/2	63.5	3/8	9.5	1/2	-	9314350006102			
T505 MB	7/8	22.5	15/32	12	2	50.8	5/8	15.9	1/2	-	9314350006102			
T506 MB	31/32	24.7	33/64	13	2-3/4	69.9	5/8	15.9	1/2	-	9314350006102			
T508 B	1	25.4	1/2	12.7	2	50.8	5/8	15.9	1/2	-	9314350006102			
T508 B 1/2	1	25.4	1/2	12.7	2-1/2	63.5	5/8	15.9	1/2	-	9314350006102			
T510 B	1-1/8	28.6	1/2	12.7	2	50.8	5/8	15.9	1/2	-	9314350006102			
T510 B 1/2	1-1/8	28.6	1/2	12.7	2-5/8	66.7	5/8	15.9	1/2	-	9314350006102			
T512 B	1-1/4	31.8	5/8	15.9	2-1/4	57.1	5/8	15.9	1/2	-	9314350006102			
T512 B 1/2	1-1/4	31.8	5/8	15.9	2-1/4	57.1	5/8	15.9	1/2	-	9314350006102			
T510 MB 1/2	1-9/32	32	2-1/2	63.5	1/4	6.35	1/4	6.35	1/2	-	9314350006102			
T512 MB 1/2	1-7/16	36	2-1/2	63.5	1/4	6.35	1/4	6.35	1/2	-	9314350006102			
T516 B	1-1/2	38	3/4	19	2-1/2	63.5	3/8	9.5	1/2	-	9314350006102			
T516 B 1/2	1-1/2	38	3/4	19	2-1/2	63.5	3/8	9.5	1/2	-	9314350006102			
T520 B 1/2	1-3/4	44.5	7/8	22.2	3-1/4	82	5/8	15.9	1/2	-	9314350006102			
T524 B 1/2	2	50.8	1	25.4	3-1/4	82	3/4	19	1/2	-	9314350006102			
T528 B 1/2	2-1/4	57.1	1-1/4	31.8	3-5/8	92	1	25.4	1/2	-	9314350006102			
T532 B 1/2	2-1/2	63.5	1-1/4	31.8	3-5/8	92	1	25.4	1/2	-	9314350006102			
T540 B 1/2	3	76.2	1-1/2	38	3-3/4	95	1-1/4	31.8	1/2	-	9314350006102			

2 Flute - Rounding Over Fillet Bit with Ball Bearing Guide - Carbide Tipped

• These bits are very popular for table and bench tops
• Profiles are variable by raising and lowering the bit
• Produces partial or elliptical radius

Product Group		Discount Group		A		B		C		Bearing No.		Shank		Barcode
R613		Z0904												
Part No.	inch	mm	inch	mm	inch	mm	inch	mm	inch	mm	inch	mm	inch	mm
TB09 B 1/2	2-1/4	57.1	1-1/8	28.6	3-1/4	82	TB9	1/2	12.7	9314350007369				
TB09 B 1/2	2-1/4	57.1	1-1/8	28.6	3-1/4	82	TB9	1/2	12.7	9314350007376				
TB09 B 1/2	2-1/4	57.1	1-1/8	28.6	3-1/4	82	TB9	1/2	12.7	9314350007383				
TB09 B 1/2	2-1/4	57.1	1-1/8	28.6	3-1/4	82	TB9	1/2	12.7	9314350007390				

1. Always keep collet clean. Replace when worn. 80% of all tool breakage is directly traced to worn "ovalised" collets. Resolve breakage by changing to a new collet.
 2. Insert shank a minimum 19mm (3/4") into collet. Holding only the upper edge of the shank by the lower portion of the collet will inevitably lead to Router Bit breakage, spindle nose wear, and collet bell-mouthing.
 3. Tighten the collet securely.
 4. Store your bits in a original packaging. Do not let them lay loose in your tool box.
 5. Clean ball bearings with solvent, then submerge them in thin oil lubricant.
 6. Have your tools serviced by a professional service shop. A properly sharpened tool is vital to the success, quality and profitability of your operation. Remove the tool for servicing whenever poor job finish or increased feed pressure indicates a dull cutting edge. Also remove the tool for servicing at the slightest sign of a chip or nick in the cutting edge.
 7. If a bit is available in 2 shank sizes, we recommend the use of the larger shank (eg; 1/2" diameter when 1/4" and 1/2" are available). This is to ensure better stability and less chatter.
 8. Whenever possible use your Router Table and Fence. Router bits over 1-1/2" diameter should only be used in bench mounted or overhead router machines. This method is recommended for all sizes.
 9. The larger the diameter the more passes are needed and slower speeds are recommended. When using bits larger than 2" (50 mm) diameter, care should be taken to ensure that speeds, feed rate and number of passes are appropriate for the diameter of the bits used. Consult the operations manual of your routing machine and/or your routing machine supplier for specific advice. See Router Speed Guide below.
 10. Router bits turn clockwise in the free hand position and anticlockwise when inverted in a router table. Always feed your workpiece against the rotation. Work holding jigs should be used in these instances. Failure to do so may harm router bits or cause injury.
- 11. WHEN USING A ROUTING MACHINE, PROTECTION AGAINST INJURY SHOULD ALWAYS BE USED.**
- Ear Muffs, Safety Glasses
 - Dust Mask And/Or Extraction Procedures

ROUTER SPEED GUIDE

ROUTER BIT DIAMETER	ROUTER BIT CUTTING LENGTH	WOOD	PLASTICS	ALUMINIUM & NON FERROUS METALS
Up to 26mm	Max 38mm	24 000	18 000	14 000
Up to 26mm	38.1mm +	18 000	14 000	12 000
26.1-50mm	Max 50mm	18 000	14 000	12 000
26.1-50mm	50.1mm +	16 000	12 000	10 000
50.1-63mm	Max 63mm	16 000	12 000	10 000
50.1-63mm	63.1mm +	12 000	10 000	9 000
63.1-77mm	Max 75mm	12 000	10 000	9 000

SPIRAL FLUTE WOOD ROUTERS FEED RATE (m/min) BASED ON 1/2" DIAM. TOOL CUTTING 19MM STOCK AT 18000RPM.

TOOL	HARD WOOD	SOFT WOOD	COMPOSITES (MDF, ETC.)
1 Flute Compression	3-15	3-15	3-12
2 Flute Compression	10-25	10-30	10-15
3 Flute Compression	12-35	12-40	15-30
4 Flute Compression	12-35	12-40	15-40
4 Flute Combined Compression	25-45	25-45	25-50
2 Flute Standard Spiral	5-10	5-11	5-11
3 Flute Standard Sprial	5-12	5-13	5-11
3 Flute Roughing	15-25	15-25	12-25
3 Flute Chipbreaker	12-35	12-40	15-30
4 Flute Rougher/Finisher	20-45	20-45	25-50

Actual feed rates will be subject to the effect of variables such as workpiece and machine rigidity, type of material (hard/soft wood), collet condition, horsepower, top edge wear, etc.

Best to start at a moderate feed rate and increase until desired finish is attained.

For smaller diameter tools (-) reduce feed rate.

For larger diameter tools (+) increase feed rate.

RESHARPENING:

Tools can be returned to Carbitool for regrinding service. Contact us at (03) 9555 2966 for more information.



ROUTER BITS

5

A wide range of premium quality Router Bits for various profiles and cuts including; • straight • edge & face forming • face moulding • joining • grooving • laminate trim • panel door • pilot panel • raised panel • slotting cutters • trim saws and more.



ECONOCUT ROUTER BITS

97

Economy range of Router Bits for various profiles and cuts.



REPLACEABLE INSERT BITS

105

Router Bits for various profiles and cuts with replaceable inserts.



DIAMOND TIPPED (PCD) & COATED ROUTER BITS

115

Diamond coated Router Bits for various profiles and cuts including; • straight • trim • diamond tipped flush trim • chamfer • inverted chamfer • rounding over • vee groove • hinge boring drills • through drills and more.



DRILLING & BORING BITS

125

A selection of tools for drilling and boring including; • through boring drills • hinge boring drills • drill countersinks • brad point drills • dowel drills • forstner bits • spade bits • step drills • glass and tile drills and more.



SAW BLADES

139

Cutting blades for various applications including; • bench saw blades • cold saw blades • diamond coated saw blades • hand saws • all purpose magic saws and more.



PLANER & BUZZER BLADES

153

Blades for planers and buzzers including; • corrugated back knives • electric hand planer blades • solid carbide planer knives • solid tungsten carbide knives • thin planer/buzzer blades



ACCESSORIES

157

A range of tools and accessories for various applications including; • gauges • guides • table and clamps • bearings • bearing assemblies • collets • arbors • sharpening stones • safety aids and more.

PRODUCT INDEX

169

Full index of all part numbers and page references in this catalogue.



ROUTER BITS

PLASTIC



6 STRAIGHT BITS

NON FERROUS METALS



8 STRAIGHT BITS

WOOD



39 EDGE AND FACE FORMING BITS



51 EDGE FORMING BITS



77 FACE MOULDING BITS



34 GROOVE FORMING BITS



84 JOINING BITS



26 LAMINATE TRIM BITS & CUTTERS



87 PANEL DOOR BITS



88 PANEL DOOR & WINDOW BITS



23 PILOT PANEL BITS



89 RAISED PANEL BITS

96 ROUTER BIT KITS



93 SLOTTING CUTTERS & ASSEMBLIES



72 SOLID SURFACE BITS



8 STRAIGHT BITS



25 TRIM SAWS

Spiral Flute - Up Cut - Solid Carbide - For Plastic

- Single flute
- For plastics including Bakelite, Acetate, Plexi, PVC, Nylon etc

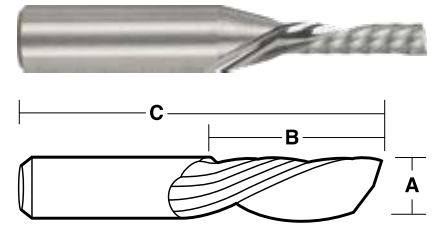

<i>Product Group</i>		<i>Discount Group</i>								
R800		Z0913		Up Cut						
Part No.	A		B		C		Shank		Barcode	
	inch	mm	inch	mm	inch	mm	inch	mm		
TSPR 02 MS	-	2	-	8	1-1/2	38.1	5/64	2	9314350014145	
TSPR 03 MS	-	3	-	10	1-1/2	38.1	1/8	3	9314350014152	
TSPR 04 S	1/8	3.18	1/2	12.7	1-1/2	38.1	1/4	6.35	9314350014176	
TSPR 04 MS	-	4	-	12	2	50.8	5/32	4	9314350014169	
TSPR 06 S	3/16	4.75	5/8	16	2	50.8	1/4	6.35	9314350014183	
TSPR 08 S	1/4	6.35	3/4	19	2	50.8	1/4	6.35	9314350014190	
TXSPR 08 S	1/4	6.35	1-1/2	38.1	3-5/32	80	1/4	6.35	9314350016880	

<i>Product Group</i>		<i>Discount Group</i>								
R801		Z0913		Down Cut						
Part No.	A		B		C		Shank		Barcode	
	inch	mm	inch	mm	inch	mm	inch	mm		
TSPL 02 MS	-	2	-	8	1-1/2	38.1	5/64	2	9314350014084	
TSPL 03 MS	-	3	-	10	1-1/2	38.1	1/8	3	9314350014091	
TSPL 04 S	1/8	3.18	1/2	12.7	1-1/2	38.1	1/4	6.35	9314350014114	
TSPL 04 MS	-	4	-	12	2	50.8	5/32	4	9314350014107	
TSPL 06 S	3/16	4.75	5/8	16	2	50.8	1/4	6.35	9314350014121	
TSPL 08 S	1/4	6.35	3/4	19	2	50.8	1/4	6.35	9314350014138	
TXSPL 08 S	1/4	6.35	1-1/2	38.1	3-5/32	80	1/4	6.35	9314350024267	

Single Flute - For Hard Plastic & Aluminium

- Solid Carbide
- For hard plastics and aluminium

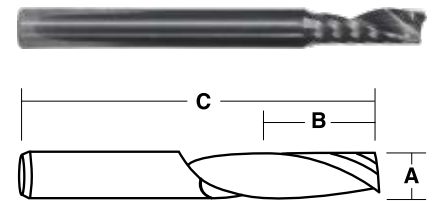

<i>Product Group</i>		<i>Discount Group</i>								
R802		Z0912								
Part No.	A		B		C		Shank		Barcode	
	inch	mm	inch	mm	inch	mm	inch	mm		
TSP08 SH	1/4	6.35	3/4	19	2-1/2	63.5	1/4	6.35	9314350017573	

Single Flute - Edge Round - For Plastic

- Solid Carbide
- For rounding the edge on plastic sheets or parts

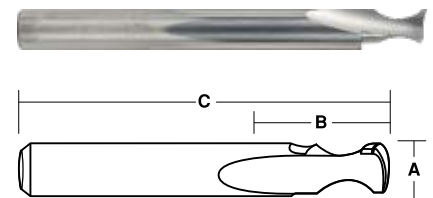

<i>Product Group</i>		<i>Discount Group</i>									
R803		Z0912									
Part No.	A		B		C		R Radius		Shank		Barcode
	inch	mm	inch	mm	inch	mm	inch	mm	inch	mm	
TSPER08 S	1/4	6.35	3/8	9.5	2-1/2	63.5	1/4	6.35	1/4	6.35	9314350017580

2 Flute - Foam Cutter

- Solid Carbide
- Ideal for cutting low density foam materials at high feed rates
- Suitable for soft spongy upholstery foam

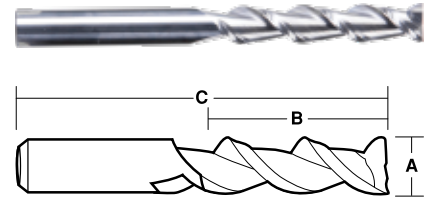

Product Group R804 **Discount Group** Z0912

Part No.	A		B		C		Shank		Barcode
	inch	mm	inch	mm	inch	mm	inch	mm	
TSFHH08	1/4	6.35	2	50.4	4	101.6	1/4	6.35	9314350017771
TSFHH12 3/8	3/8	9.5	2	50.4	4	101.6	3/8	9.525	9314350017511

3 Flute - Polystyrene Bit

- Solid Carbide
- For polystyrene
- Suitable for surfboard foam

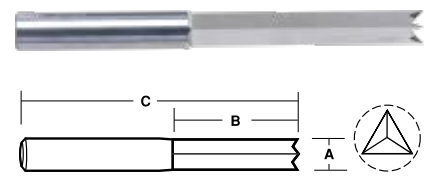

Product Group R805 **Discount Group** Z0912

Part No.	A		B		C		Shank		Barcode
	inch	mm	inch	mm	inch	mm	inch	mm	
TSF 8	1/4	6.35	2-1/4	57.1	4	101.6	1/4	6.35	9314350020009
TSF12 3/8	3/8	9.5	2-1/4	57.1	4	101.6	3/8	9.525	9314350020016

Single Spoon Flute - For Plastic & Aluminium

- Solid Carbide
- For aluminium and some soft plastics
- Cost effective solution for obtaining excellent finish in most plastics

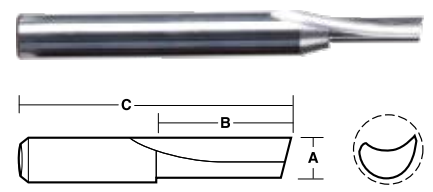

Product Group R806 **Discount Group** Z0912

Part No.	A		B		C		Shank		Barcode
	inch	mm	inch	mm	inch	mm	inch	mm	
TSP 04 S	1/8	3.18	5/16	7.94	2-1/4	57.15	1/4	6.35	9314350016804
TSP 04 MS	5/32	4	1/2	12.7	2-1/4	57.15	1/4	6.35	9314350024335
TSP 06 S	3/16	4.75	1/2	12.7	2-1/4	57.15	1/4	6.35	9314350017597
TSP 06 MS	15/64	6	5/8	16	2-1/4	57.15	1/4	6.35	9314350025059
TSP 08 S	1/4	6.35	5/8	16	2-1/4	57.15	1/4	6.35	9314350017603



2 Flute – For Non Ferrous Metals – Solid Carbide

- For non ferrous metals eg Aluminium, Laminates etc
- Down cut are ideal for trimming laminates and through cutting
- Down cut pushes chips below the workpiece.
- Up cut are ideal for groove slotting and routing

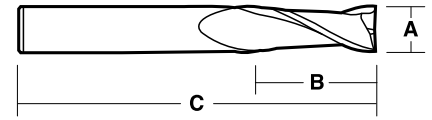

Product Group		Discount Group								
R807		Z0912		Up Cut						
Part No.	A		B		C		Shank		Barcode	
	inch	mm	inch	mm	inch	mm	inch	mm		
TSR 8	1/4	6.35	3/4	19	2-1/2	63.5	1/4	6.35	9314350000612	
TXSR 8	1/4	6.35	1	25.4	2-1/2	63.5	1/4	6.35	9314350016781	
TSR 12 3/8	3/8	9.53	1	25.4	2-1/2	63.5	3/8	9.53	9314350000629	
TSR 16 1/2	1/2	12.7	1-1/4	31.75	3	76.2	1/2	12.7	9314350000636	

Product Group		Discount Group								
R808		Z0912		Down Cut						
Part No.	A		B		C		Shank		Barcode	
	inch	mm	inch	mm	inch	mm	inch	mm		
TSL 8	1/4	6.35	3/4	19	2-1/2	63.5	1/4	6.35	9314350000582	
TXSL 8	1/4	6.35	1	25.4	2-1/2	63.5	1/4	6.35	9314350016798	
TSL 12 3/8	3/8	9.53	1	25.4	2-1/2	63.5	3/8	9.53	9314350000599	
TSL 16 1/2	1/2	12.7	1-1/4	31.75	3	76.2	1/2	12.7	9314350000605	

3 Flute – Roughing Spiral Bit – Up Cut – Solid Carbide

- For increased feed rates to give fast routing of hard materials
- Chip breaker to break swarf into smaller particles for easier ejection

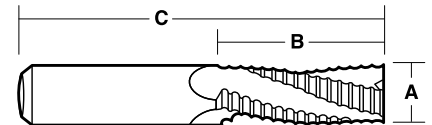

Product Group		Discount Group								
R809		Z0912		Up Cut						
Part No.	A		B		C		Shank		Barcode	
	inch	mm	inch	mm	inch	mm	inch	mm		
TSRR 8	1/4	6.35	3/4	19.05	2-1/2	63.5	1/4	6.35	9314350016637	
TSRR 8 M	-	8	-	25	-	63	1/4	6.35	9314350016644	
TSRR 12 3/8	3/8	9.53	1	25.4	2-1/2	63.5	3/8	9.53	9314350016651	
TSRR 10 M	-	10	-	25	-	75	25/64	10	9314350016675	
TSRR 12 M	-	12	-	32	-	75	15/32	12	9314350016682	
TSRR 16 1/2	1/2	12.7	1-1/4	31.75	3	76.2	1/2	12.7	9314350016699	
TSRR 16 M	-	16	-	35	-	92	5/8	16	9314350016705	
TSRR 20 M	-	20	-	40	-	104	25/32	20	9314350016712	

Product Group		Discount Group								
R810		Z0912		Down Cut						
Part No.	A		B		C		Shank		Barcode	
	inch	mm	inch	mm	inch	mm	inch	mm		
TSLR 12 3/8	3/8	9.53	1	25.4	2-1/2	63.5	3/8	9.53	9314350018471	
TSLR 16 1/2	1/2	12.7	1-1/4	31.75	3	76.2	1/2	12.7	9314350018488	
TSLR 16 M	-	16	-	35	-	92	5/8	16	9314350018496	

3 Flute - Chipbreaker Spiral Bit - Up Cut - Solid Carbide

- Staggered chip breaker grind on each flute to produce small chips
- Obtains a clean cut at high feed rates
- minimises vibration
- For hardwoods and dense materials

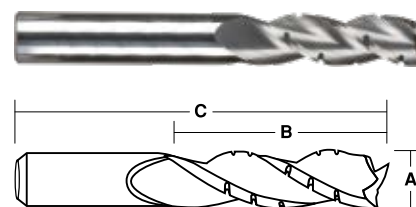

ROUTER BITS

<u>Product Group</u>		<u>Discount Group</u>								
R811		Z0912		Up Cut						
Part No.	A		B		C		Shank		Barcode	
	inch	mm	inch	mm	inch	mm	inch	mm		
TSRCB 12 3/8	3/8	9.5	1-1/4	31.8	3	76.2	3/8	9.53	9314350017788	
TXSRCB 16 1/2	1/2	12.7	1-3/4	44.4	3-5/8	92	1/2	12.7	9314350017566	
TSRCB 16 M	-	16	-	41	-	92	5/8	16	9314350017795	

<u>Product Group</u>		<u>Discount Group</u>								
R812		Z0912		Down Cut						
Part No.	A		B		C		Shank		Barcode	
	inch	mm	inch	mm	inch	mm	inch	mm		
TSLCB 12 3/8	3/8	9.5	1-1/4	31.8	3	76.2	3/8	9.53	9314350017801	
TXSLCB 16 1/2	1/2	12.7	1-3/4	44.4	3-5/8	92	1/2	12.7	9314350017818	
TSLCB 16 M	-	16	-	41	-	92	5/8	16	9314350017825	

4 Flute - Rougher Finisher Bit - Up Cut - Solid Carbide

- Staggered chip breaker grind on alternate flutes produces small chips
- Obtains a clean cut at high feed rates
- minimises vibration

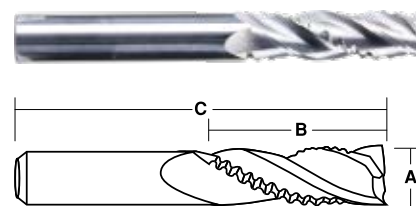

<u>Product Group</u>		<u>Discount Group</u>								
R813		Z0912		Up Cut						
Part No.	A		B		C		Shank		Barcode	
	inch	mm	inch	mm	inch	mm	inch	mm		
T4SRRF12 3/8	3/8	9.5	1-1/4	31.75	3	76.2	3/8	9.53	9314350018396	
T4SRRF 16 1/2	1/2	12.7	1-1/4	31.75	3	76.2	1/2	12.7	9314350018597	
T4XSRRF 16 1/2	1/2	12.7	1-1/2	38	3-5/8	92	1/2	12.7	9314350018426	

<u>Product Group</u>		<u>Discount Group</u>								
R814		Z0912		Down Cut						
Part No.	A		B		C		Shank		Barcode	
	inch	mm	inch	mm	inch	mm	inch	mm		
T4SLRF12 3/8	3/8	9.5	1-1/4	31.75	3	76.2	3/8	9.53	9314350018402	
T4SLRF 16 1/2	1/2	12.7	1-1/4	31.75	3	76.2	1/2	12.7	9314350018419	
T4XSLRF 16 1/2	1/2	12.7	1-1/2	38	3-5/8	92	1/2	12.7	9314350018603	



2 Flute - Finishing Spiral Bit - Solid Carbide

- For superior edge finish on hardwoods, softwoods, laminates, composites etc
- Up cut brings the swarf up and out of the cut
- Down cut drives the swarf down and out of the cut

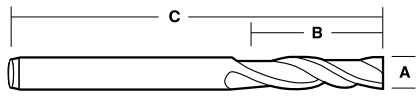

Product Group R815 **Discount Group** Z0912

Up Cut

Part No.	A		B		C		Shank		Barcode
	inch	mm	inch	mm	inch	mm	inch	mm	
TSRW 4	1/8	3.18	1/2	12.7	2-1/4	57.15	1/4	6.35	9314350010567
TSRW 5	5/32	3.96	5/8	16	2-1/4	57.15	1/4	6.35	9314350015456
TSRW 6	3/16	4.75	3/4	19	2-1/4	57.15	1/4	6.35	9314350015463
TSSRW 8	1/4	6.35	5/8	16	2	50.8	1/4	6.35	9314350018160
TSRW 8	1/4	6.35	3/4	19	2-1/2	63.5	1/4	6.35	9314350008571
TXSRW 8	1/4	6.35	1	25.4	2-1/2	63.5	1/4	6.35	9314350015487
TSRW 10 5/16	5/16	7.94	1	25.4	2-1/2	63.5	5/16	7.938	9314350010550
TSRW 10 1/2	5/16	7.94	1	25.4	3	76.2	1/2	12.7	9314350010543
TSRW 8 M	-	8	-	25	-	63	5/16	8	9314350015470
TSRW 12 3/8	3/8	9.53	1	25.4	2-1/2	63.5	3/8	9.53	9314350008588
TSRW 12 1/2	3/8	9.53	1	25.4	3	76.2	1/2	12.7	9314350012301
TSRW 10 M	-	10	-	25	-	75	25/64	10	9314350015395
TSRW 12 M	-	12	-	32	-	75	15/32	12	9314350015401
TSRW 16 1/2	1/2	12.7	1-1/4	31.75	3	76.2	1/2	12.7	9314350008595
TXSRW 16 1/2	1/2	12.7	1-1/4	31.75	4	101.6	1/2	12.7	9314350015425
TXXSRW 16 1/2	1/2	12.7	2	50.8	4	101.6	1/2	12.7	9314350015432
TSRW 16 M	-	16	-	35	-	92	5/8	16	9314350015418
TSRW 20 M	-	20	-	40	-	104	25/32	20	9314350015449

TiN Coated - Up Cut

Part No.	Barcode
TTSRW 4	9314350010598
TTSRW 5	9314350015760
TTSRW 6	9314350015777
TTSSRW 8	9314350025042
TTSRW 8	9314350008601
TTXSRW 8	9314350015791
TTSRW 10 5/16	9314350010581
TTSRW 10 1/2	9314350010574
TTSRW 8 M	9314350015784
TTSRW 12 3/8	9314350008618
TTSRW 12 1/2	9314350012295
TTSRW 10 M	9314350015708
TTSRW 12 M	9314350015715
TTSRW 16 1/2	9314350008625
TTXSRW 16 1/2	9314350015739
TTXSRW 16 1/2	9314350015746
TTSRW 16 M	9314350015722
TTSRW 20 M	9314350015753

Product Group R816 **Discount Group** Z0912

Down Cut

Part No.	A		B		C		Shank		Barcode
	inch	mm	inch	mm	inch	mm	inch	mm	
TSLW 4	1/8	3.18	1/2	12.7	2-1/4	57.15	1/4	6.35	9314350015333
TSLW 5	5/32	3.96	5/8	16	2-1/4	57.15	1/4	6.35	9314350015340
TSLW 6	3/16	4.75	3/4	19	2-1/4	57.15	1/4	6.35	9314350015357
TSLW 8	1/4	6.35	3/4	19	2-1/2	63.5	1/4	6.35	9314350015364
TXSLW 8	1/4	6.35	1	25.4	2-1/2	63.5	1/4	6.35	9314350015388
TSLW 10 5/16	5/16	7.94	1	25.4	2-1/2	63.5	5/16	7.938	9314350015227
TSLW 10 1/2	5/16	7.94	1	25.4	3	76.2	1/2	12.7	9314350015234
TSLW 8 M	-	8	-	25	-	63	5/16	8	9314350015371
TSLW 12 3/8	3/8	9.53	1	25.4	2-1/2	63.5	3/8	9.53	9314350015258
TSLW 12 1/2	3/8	9.53	1	25.4	3	76.2	1/2	12.7	9314350015265
TSLW 10 M	-	10	-	25	-	75	25/64	10	9314350015241
TSLW 12 M	-	12	-	32	-	75	15/32	12	9314350015272
TSLW 16 1/2	1/2	12.7	1-1/4	31.75	3	76.2	1/2	12.7	9314350015289
TXSLW 16 1/2	1/2	12.7	1-1/4	31.75	4	101.6	1/2	12.7	9314350015302
TXXSLW 16 1/2	1/2	12.7	2	50.8	4	101.6	1/2	12.7	9314350015319
TSLW 16 M	-	16	-	35	-	92	5/8	16	9314350015296
TSLW 20 M	-	20	-	40	-	104	25/32	20	9314350015326

TiN Coated - Down Cut

Part No.	Barcode
TTSLW 4	9314350015647
TTSLW 5	9314350015654
TTSLW 6	9314350015661
TTSLW 8	9314350015678
TTXSLW 8	9314350015692
TTSLW 10 5/16	9314350015531
TTSLW 10 1/2	9314350015548
TTSLW 8 M	9314350015685
TTSLW 12 3/8	9314350015562
TTSLW 12 1/2	9314350015579
TTSLW 10 M	9314350015555
TTSLW 12 M	9314350015586
TTSLW 16 1/2	9314350015593
TTXSLW 16 1/2	9314350015616
TTXSLW 16 1/2	9314350015623
TTSLW 16 M	9314350015609
TTSLW 20 M	9314350015630

3 Flute - Finishing Spiral Bit - Solid Carbide

- Produces extremely smooth finishes
- Use for natural timber and composites

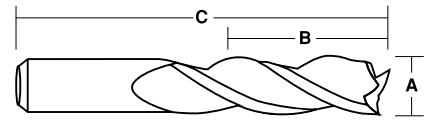

ROUTER BITS

Product Group		Discount Group								
R817		Z0912		Up Cut						
Part No.	A		B		C		Shank		Barcode	
	inch	mm	inch	mm	inch	mm	inch	mm		
T3SRW8	1/4	6.35	3/4	19	2-1/2	63	1/4	6.35	9314350017474	
T3SRW12 3/8	3/8	9.5	1-1/4	31.75	3	76	3/8	9.53	9314350017481	
T3SRW16 1/2	1/2	12.7	1-1/4	31.75	3	76	1/2	12.7	9314350017498	

Product Group		Discount Group								
R818		Z0912		Down Cut						
Part No.	A		B		C		Shank		Barcode	
	inch	mm	inch	mm	inch	mm	inch	mm		
T3SLW8	1/4	6.35	3/4	19	2-1/2	63	1/4	6.35	9314350017740	
T3SLW12 3/8	3/8	9.5	1-1/4	31.75	3	76	3/8	9.53	9314350017757	
T3SLW16 1/2	1/2	12.7	1-1/4	31.75	3	76	1/2	12.7	9314350017764	

Spiral Bit with Ball End

- Solid Carbide
- Used for round bottom work where extra depth and a superior finish is required

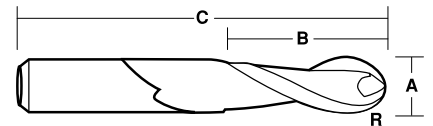

Product Group		Discount Group									
R819		Z0912									
Part No.	A		B		C		R Radius		Shank		Barcode
	inch	mm	inch	mm	inch	mm	inch	mm	inch	mm	
TSRWB 8	1/4	6.35	3/4	19	2-1/2	63.5	1/8	3.2	1/4	6.35	9314350020023
TSRWB 12 3/8	3/8	9.5	1	25.4	3	76.2	3/16	4.8	3/8	9.53	9314350020030
TSRWB 16 1/2	1/2	12.7	1-1/4	31.8	3	76.2	1/4	6.35	1/2	12.7	9314350017504

Single Flute - Compression Bit

- Advanced tool geometry to achieve higher feed rates
- Geometry minimizes chipping and furring on the top and bottom surfaces
- Ideal for cutting double sided laminates and natural timbers.

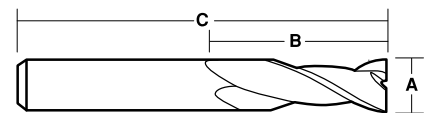

Product Group		Discount Group								
R820		Z0912								
Part No.	A		B		C		Shank		Barcode	
	inch	mm	inch	mm	inch	mm	inch	mm		
TSRM 12 3/8	3/8	9.53	1	25.4	3	76.2	3/8	9.53	9314350016729	
TSRM 10 M	-	10	-	25	-	75	25/64	10	9314350016736	
TSRM 12 M	-	12	-	32	-	83	15/32	12	9314350016743	
TSRM 16 1/2	1/2	12.7	1-1/4	31.8	3	76.2	1/2	12.7	9314350016750	
TSRM 16 M	-	16	-	35	-	92	5/8	16	9314350016767	
TSRM 20 M	-	20	-	40	-	104	25/32	20	9314350016774	



Compression Bits

- Advanced tool geometry to achieve higher feed rates
- Geometry minimises chipping and furring on the top and bottom surfaces
- Ideal for cutting double sided laminates and natural timbers.

2 Flute - Compression Bit

<i>Product Group</i>		<i>Discount Group</i>											
R821		Z0912											
Part No.	A		B		B1		C		Shank		Barcode		
	inch	mm	inch	mm	inch	mm	inch	mm	inch	mm			
T2ESRM08	1/4	6.35	7/8	22.2	-	8	2-1/2	63.5	1/4	6.35	9314350017283		
T2ESRM8M	-	8	-	25	-	8	-	63	5/16	8	9314350017306		
T2ESRM12 3/8	3/8	9.5	1-1/8	28	-	8	3	76	3/8	9.53	9314350017313		
T2ESRM10M	-	10	-	28	-	8	-	75	25/64	10	9314350017702		
T2SRM16 1/2	1/2	12.7	1	25.4	-	10	3	76	1/2	12.7	9314350017337		
T2XSRM16 1/2	1/2	12.7	1-3/8	35	-	10	3-5/8	92	1/2	12.7	9314350017351		

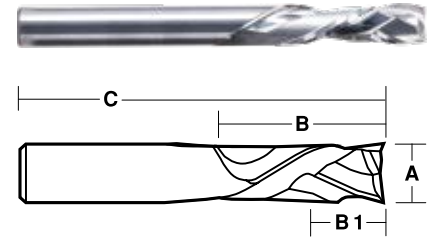

2 Flute - Compression Bit - For Mortising - Short Up Cut

<i>Product Group</i>		<i>Discount Group</i>											
R822		Z0912											
Part No.	A		B		B1		C		Shank		Barcode		
	inch	mm	inch	mm	inch	mm	inch	mm	inch	mm			
T2SRM08 Q	1/4	6.35	7/8	22.2	-	5	2-1/2	63.5	1/4	6.35	9314350017290		
T2SRM8M Q	-	8	-	25	-	5	-	63	5/16	8	9314350017696		
T2SRM12 3/8 Q	3/8	9.5	7/8	22.2	-	5	3	76	3/8	9.53	9314350017320		
T2SRM10M Q	-	10	-	22.2	-	5	-	75	25/64	10	9314350017719		
T2SRM16 1/2 Q	1/2	12.7	1	25.4	-	6.35	3	76	1/2	12.7	9314350017344		
T2XSRM16 1/2 Q	1/2	12.7	1-5/8	41.3	-	6.35	3-5/8	92	1/2	12.7	9314350017368		

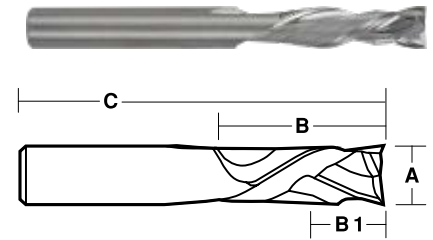

3 Flute - Compression Bit

- 3 Flute allows for increased high speed machining with high spindle speeds

<i>Product Group</i>		<i>Discount Group</i>											
R823		Z0912											
Part No.	A		B		B1		C		Shank		Barcode		
	inch	mm	inch	mm	inch	mm	inch	mm	inch	mm			
T3ESRM12 3/8	3/8	9.5	1-1/8	28.6	-	8	3	76	3/8	9.53	9314350017382		
T3ESRM12 12M	3/8	9.5	-	22	-	8	-	80	15/32	12	9314350046320		
T3ESRM10M	-	10	-	28	-	8	-	75	25/64	10	9314350017726		
T3SRM16 1/2	1/2	12.7	1	25.4	-	10	3	76	1/2	12.7	9314350017405		
T3XSRM16 1/2	1/2	12.7	1-3/8	35	-	10	3-5/8	92	1/2	12.7	9314350017429		

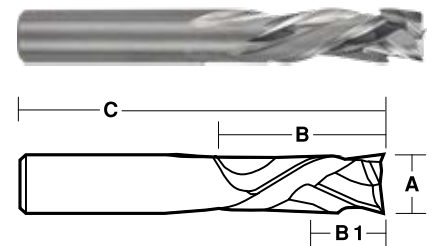

3 Flute - Compression Bit For Mortising - Short Upcut

- Advanced tool geometry to achieve higher feed rates

Product Group	Discount Group
R824	Z0912

Part No.	A		B		B1		C		Shank		Barcode
	inch	mm	inch	mm	inch	mm	inch	mm	inch	mm	
T3SRM12 3/8 Q	3/8	9.5	7/8	22.2	-	5	3	76	3/8	9.53	9314350017399
T3SRM10M Q	-	10	-	22.2	-	5	-	75	25/64	10	9314350017733
T3SRM16 1/2 Q	1/2	12.7	1	25.4	-	6.35	3	76	1/2	12.7	9314350017412
T3XSRM16 1/2 Q	1/2	12.7	1-5/8	41	-	6.35	3-5/8	92	1/2	12.7	9314350017436

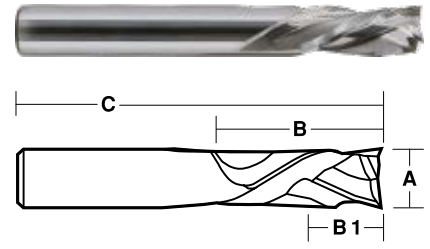

4 Flute - Compression Bit

- 4 Flute allows for increased high speed machining with high spindle speeds

Product Group	Discount Group
R825	Z0912

Part No.	A		B		B1		C		Shank		Barcode
	inch	mm	inch	mm	inch	mm	inch	mm	inch	mm	
T4SRM16 1/2	1/2	12.7	1	25.4	-	10	3	76	1/2	12.7	9314350017443
T4XSRM16 1/2	1/2	12.7	1-3/8	35	-	10	3-5/8	92	1/2	12.7	9314350017467

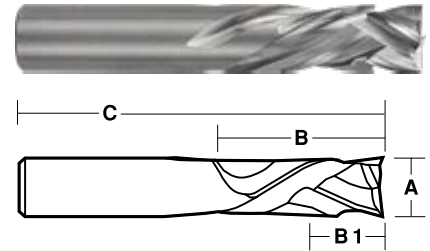

4 Flute - Compression Bit For Mortising - Short Up Cut

- 4 Flute allows for increased high speed machining with high spindle speeds

Product Group	Discount Group
R826	Z0912

Part No.	A		B		B1		C		Shank		Barcode
	inch	mm	inch	mm	inch	mm	inch	mm	inch	mm	
T4SRM16 1/2 Q	1/2	12.7	1	25.4	-	6.35	3	76	1/2	12.7	9314350017450
T4XSRM16 1/2 Q	1/2	12.7	1-5/8	41	-	6.35	3-5/8	92	1/2	12.7	9314350017276

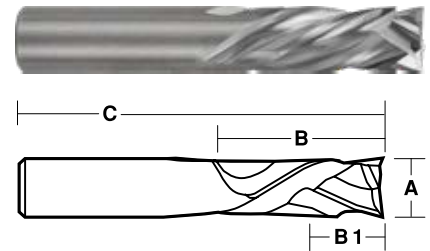

4 Flute - Combined Rougher/Finisher Compression Bit

- Advanced tool geometry to achieve higher feed rates
- Geometry minimises chipping and furring on the top and bottom surfaces

Product Group	Discount Group
R827	Z0912

Part No.	A		B		B1		C		Shank		Barcode
	inch	mm	inch	mm	inch	mm	inch	mm	inch	mm	
T4SRMRF16 1/2	1/2	12.7	1	25.4	-	10	3	76	1/2	12.7	9314350017528
T4XSRMRF16 1/2	1/2	12.7	1-3/8	35	-	10	3-5/8	92	1/2	12.7	9314350017535
T4XSRMRF16 1/2	1/2	12.7	1-3/4	44.4	-	10	3-5/8	92	1/2	12.7	9314350017542

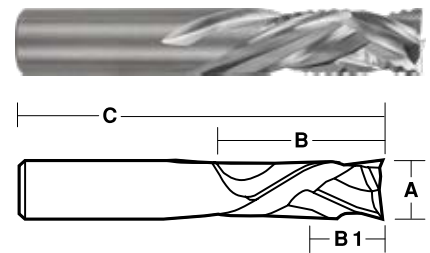

4 Flute - Combined Rougher/Finisher Compression Bit - Short Up Cut

- Chip breaker flute to break swarf into smaller particles
- Achieves high feed rates for easy ejection

Product Group	Discount Group
R828	Z0912

Part No.	A		B		B1		C		Shank		Barcode
	inch	mm	inch	mm	inch	mm	inch	mm	inch	mm	
T4SRMRF10M Q	-	10	-	22.2	-	5	-	75	25/64	10	9314350019621

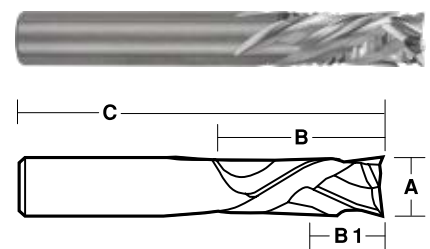

Fibreglass Bit – Solid Carbide – Diamond Cut

- Cutters with end cutting capability (E/C) can be used for plunge routing
- For routing highly abrasive materials ie. glass epoxy and fibreglass

Product Group **Discount Group**
R829 Z0912

Part No.	A		B		C		Shank		Barcode
	inch	mm	inch	mm	inch	mm	inch	mm	
TG 8	1/4	6.35	3/4	19	2	50.8	1/4	6.35	9314350000520
TG 12 3/8	3/8	9.5	1	25.4	2-1/2	63.5	3/8	9.53	9314350000544
TG 16 1/2	1/2	12.7	1	25.4	3	76	1/2	12.7	9314350000568

Product Group **Discount Group**
R835 Z0912

Part No.	A		B		C		Shank		Barcode
	inch	mm	inch	mm	inch	mm	inch	mm	
TG 8 E/C	1/4	6.35	3/4	19	2	50.8	1/4	6.35	9314350000537
TG 12 3/8 E/C	3/8	9.5	1	25.4	2-1/2	63.5	3/8	9.53	9314350000551
TG 16 1/2 E/C	1/2	12.7	1	25.4	3	76	1/2	12.7	9314350000575

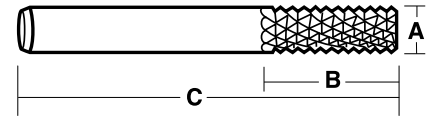

Fibreglass Bit with Pilot – Solid Carbide – Diamond Cut

- Used for trimming fibreglass sheets.
- Pilot enables the tool to run on frames or templates

Product Group **Discount Group**
R830 Z0912

Part No.	A		B		C		Shank		Barcode
	inch	mm	inch	mm	inch	mm	inch	mm	
TG 8 P	1/4	6.35	3/4	19	2-1/2	63	1/4	6.35	9314350017665
TG 12 3/8 P	3/8	9.5	3/4	19	-	83	3/8	9.53	9314350017672
TG 16 1/2 P	1/2	12.7	7/8	22	3	76	1/2	12.7	9314350017689

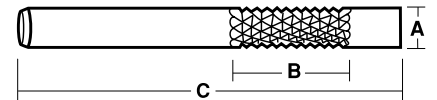

Single Flute - Straight Flute - HSS

- For general purpose routing and grooving.
- Excellent chip clearance
- Can be used to rout aluminium, zinc, copper and other soft metals

Product Group R500 **Discount Group** Z0906

Part No.	A		B		C		Shank		Barcode
	inch	mm	inch	mm	inch	mm	inch	mm	
H 204 S	1/8	3.2	3/8	9.5	1-5/8	41	1/4	6.35	9314350003019
H 205 S	5/32	4	5/16	7.9	2	50.8	1/4	6.35	9314350000025
H 204 MS	5/32	4	5/16	7.9	2	50.8	1/4	6.35	9314350000032
H 208 S	1/4	6.35	3/4	19	2	50.8	1/4	6.35	9314350003033

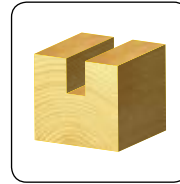
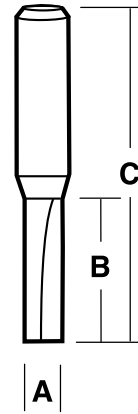

2 Flute - Straight Flute - HSS

- For general purpose routing, grooving and rebating

Product Group R501 **Discount Group** Z0906

Part No.	A		B		C		Shank		Barcode
	inch	mm	inch	mm	inch	mm	inch	mm	
H 208	1/4	6.35	5/8	15.9	1-5/8	41	1/4	6.35	9314350003040
HX 208	1/4	6.35	1-1/8	28.6	2-3/8	60	1/4	6.35	9314350003057
H 210	5/16	7.9	3/4	19	1-3/4	44.4	1/4	6.35	9314350003064
H 212	3/8	9.5	3/4	19	1-3/4	44.4	1/4	6.35	9314350003071
H 214	7/16	11.1	3/4	19	1-3/4	44.4	1/4	6.35	9314350000063
H 216	1/2	12.7	3/4	19	1-3/4	44.4	1/4	6.35	9314350003088
H 213 M	33/64	13	3/4	19	1-3/4	44.4	1/4	6.35	9314350000070
H 220	5/8	15.9	5/8	15.9	1-3/4	44.4	1/4	6.35	9314350000087
H 216 M	5/8	16	5/8	15.9	1-3/4	44.4	1/4	6.35	9314350000094
H 219 M	3/4	19	5/8	15.9	1-3/4	44.4	1/4	6.35	9314350003095
H 224	3/4	19	5/8	15.9	1-3/4	44.4	1/4	6.35	9314350003101

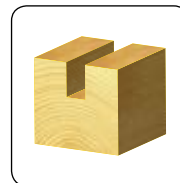
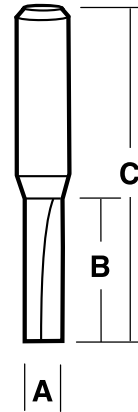

2 Flute - Straight Flute - HSS

- For general purpose routing, grooving and rebating

Product Group R502 **Discount Group** Z0906

Part No.	A		B		C		Shank		Barcode
	inch	mm	inch	mm	inch	mm	inch	mm	
H 1416	1/2	12.7	1-1/4	31.8	2-3/4	70	1/2	12.7	9314350003132

ROUTER BITS



Single Flute - Straight Flute - Solid Carbide

- For general purpose routing and grooving.
- Excellent chip clearance
- Suitable for a wide range of materials, hardwood, softwood, acrylic sheet, etc

Product Group R503 **Discount Group** Z0912

Part No.	A		B		C		Shank		Barcode
	inch	mm	inch	mm	inch	mm	inch	mm	
T 202 S	1/16	1.6	3/16	4.8	1-1/2	38.1	1/4	6.35	9314350003149
T 202 MS	5/64	2	3/16	4.8	1-1/2	38.1	1/4	6.35	9314350003156
T 203 S	3/32	2.4	3/16	4.8	1-1/2	38.1	1/4	6.35	9314350003163
T 203 MS	-	3	1/4	6.35	1-1/2	38.1	1/4	6.35	9314350003170
T 204 S	1/8	3.2	5/16	7.9	1-1/2	38.1	1/4	6.35	9314350003187
T 205 S	5/32	4	3/8	9.5	1-1/2	38.1	1/4	6.35	9314350003194
T 204 MS	5/32	4	7/16	11.1	1-1/2	38.1	1/4	6.35	9314350003200
T 206 S	3/16	4.8	1/2	12.7	1-1/2	38.1	1/4	6.35	9314350003217
T 205 MS	-	5	1/2	12.7	1-1/2	38.1	1/4	6.35	9314350003224
T 207 S	7/32	5.5	1/2	12.7	1-1/2	38.1	1/4	6.35	9314350003231
T 206 MS	15/64	6	5/8	15.9	1-1/2	38.1	1/4	6.35	9314350003248
T 208 S	1/4	6.35	5/8	15.9	1-1/2	38.1	1/4	6.35	9314350003255

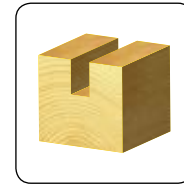
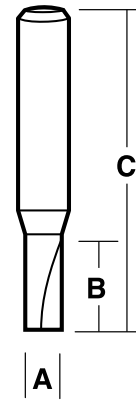

Single Flute - Straight Flute - Solid Carbide - Long Series

- For maximum rigidity use the standard length bits (above) where possible
- Suitable for a wide range of materials, hardwood, softwood, acrylic sheet, etc

Product Group R504 **Discount Group** Z0912

Part No.	A		B		C		Shank		Barcode
	inch	mm	inch	mm	inch	mm	inch	mm	
T 1804 S	1/8	3.2	1/2	12.7	2-1/4	57.1	1/4	6.35	9314350003262
T 1804 MS	5/32	4	5/8	15.9	2-1/4	57.1	1/4	6.35	9314350003279
T 1806 S	3/16	4.8	3/4	19	2-1/4	57.1	1/4	6.35	9314350003286
T 1805 MS	-	5	3/4	19	2-1/4	57.1	1/4	6.35	9314350003293
T 1806 MS	15/64	6	1	25.4	2-1/4	57.1	1/4	6.35	9314350003309
T 1808 S	1/4	6.35	1	25.4	2-1/4	57.1	1/4	6.35	9314350003316

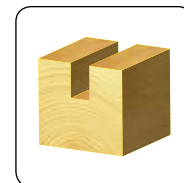
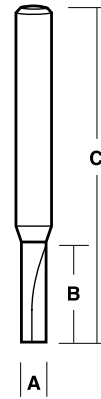

2 Flute - Straight Flute - Solid Carbide

- For all general purpose routing, grooving, rebating.
- For longer life in routing abrasive type materials

Product Group R505 **Discount Group** Z0912

Part No.	A		B		C		Shank		Barcode
	inch	mm	inch	mm	inch	mm	inch	mm	
T 206 M	15/64	6	5/8	16	1-1/2	38.1	1/4	6.35	9314350003323
TX 206 M	15/64	6	1-1/8	28.6	2-1/4	57.1	1/4	6.35	9314350003330
T 208	1/4	6.35	5/8	15.9	1-1/2	38.1	1/4	6.35	9314350003347
TX 208	1/4	6.35	1-1/8	28.6	2-1/4	57.1	1/4	6.35	9314350003354
TXX 208	1/4	6.35	1-1/8	28.6	2-1/2	63.5	1/4	6.35	9314350003361

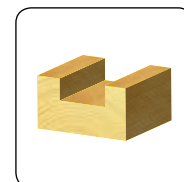
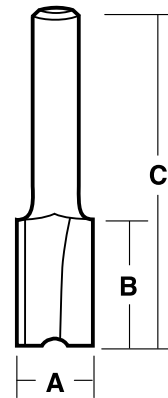

2 Flute - Carbide Tipped

- For all general purpose routing, grooving, rebating.

Product Group **Discount Group**
 R506 Z0904

Part No.	A		B		C		Shank		Barcode
	inch	mm	inch	mm	inch	mm	inch	mm	
T 207 M	-	7	3/4	19	1-3/4	44.4	1/4	6.35	9314350003378
T 209	9/32	7.1	3/4	19	1-3/4	44.4	1/4	6.35	9314350000117
T 210	5/16	7.9	3/4	19	1-3/4	44.4	1/4	6.35	9314350003385
T 208 M	5/16	8	3/4	19	1-3/4	44.4	1/4	6.35	9314350003392
TX 208 M	5/16	8	1	25.4	2	50.8	1/4	6.35	9314350009202
T 209 M	23/64	9	3/4	19	1-3/4	44.4	1/4	6.35	9314350003408
T 212	3/8	9.5	3/4	19	1-3/4	44.4	1/4	6.35	9314350003415
TX 212	3/8	9.5	1	25.4	2	50.8	1/4	6.35	9314350003422
T 210 M	25/64	10	3/4	19	1-3/4	44.4	1/4	6.35	9314350003439
TX 210 M	25/64	10	1	25.4	2	50.8	1/4	6.35	9314350000124
T 211 M	7/16	11	3/4	19	1-3/4	44.4	1/4	6.35	9314350003446
T 214	7/16	11.1	3/4	19	1-3/4	44.4	1/4	6.35	9314350000131
T 212 M	15/32	12	3/4	19	1-3/4	44.4	1/4	6.35	9314350003453
T 216	1/2	12.7	3/4	19	1-3/4	44.4	1/4	6.35	9314350003460
TX 216	1/2	12.7	1	25.4	2	50.8	1/4	6.35	9314350003477
T 213 M	33/64	13	3/4	19	1-3/4	44.4	1/4	6.35	9314350003484
TX 213 M	33/64	13	1	25.4	2	50.8	1/4	6.35	9314350003491
T 214 M	35/64	14	3/4	19	1-3/4	44.4	1/4	6.35	9314350003507
T 218	9/16	14.3	3/4	19	1-3/4	44.4	1/4	6.35	9314350000148
T 215 M	19/32	15	3/4	19	1-3/4	44.4	1/4	6.35	9314350003514
T 220	5/8	15.9	3/4	19	1-3/4	44.4	1/4	6.35	9314350003521
TX 220	5/8	15.9	1	25.4	2	50.8	1/4	6.35	9314350000155
T 216 M	5/8	16	3/4	19	1-3/4	44.4	1/4	6.35	9314350003538
TX 216 M	5/8	16	1	25.4	2	50.8	1/4	6.35	9314350009219
T 216.5 M	21/32	16.5	3/4	19	1-3/4	44.4	1/4	6.35	9314350003545
T 217 M	43/64	17	3/4	19	1-3/4	44.4	1/4	6.35	9314350003552
T 222	11/16	17.5	3/4	19	1-3/4	44.4	1/4	6.35	9314350000162
T 218 M	45/64	18	3/4	19	1-3/4	44.4	1/4	6.35	9314350003569
TX 218 M	45/64	18	1	25.4	2	50.8	1/4	6.35	9314350003576
T 218.5 M	-	18.5	3/4	19	1-3/4	44.4	1/4	6.35	9314350003583
T 219 M	3/4	19	3/4	19	1-3/4	44.4	1/4	6.35	9314350003590
T 224	3/4	19	3/4	19	1-3/4	44.4	1/4	6.35	9314350003606
T 219.5 M	49/64	19.5	3/4	19	1-3/4	44.4	1/4	6.35	9314350003613
T 220 M	-	20	3/4	19	1-3/4	44.4	1/4	6.35	9314350003620
T 226	13/16	20.6	3/4	19	1-3/4	44.4	1/4	6.35	9314350000179
T 221 M	53/64	21	3/4	19	1-3/4	44.4	1/4	6.35	9314350003637
T 222 M	-	22	3/4	19	1-3/4	44.4	1/4	6.35	9314350000186
T 228	7/8	22.2	3/4	19	1-3/4	44.4	1/4	6.35	9314350000193
T 225 M	63/64	25	3/4	19	1-3/4	44.4	1/4	6.35	9314350003644
T 232	1	25.4	3/4	19	1-3/4	44.4	1/4	6.35	9314350003651

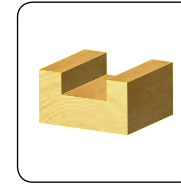
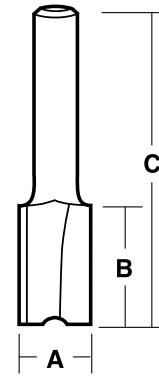

Single Flute - Carbide Tipped

- For all general purpose routing, grooving, rebating.
- Excellent chip clearance
- Suitable for a wide range of materials

Product Group **Discount Group**
 R507 Z0904

Part No.	A		B		C		Shank		Barcode
	inch	mm	inch	mm	inch	mm	inch	mm	
T 1410 MS	25/64	10	1	25.4	2-5/8	67	1/2	12.7	9314350008731
T 1413 MS	33/64	13	1-1/2	38.1	3-5/32	80.2	1/2	12.7	9314350008557
T 1416 MS	5/8	16	1-1/2	38.1	3-5/32	80.2	1/2	12.7	9314350008564

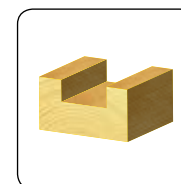
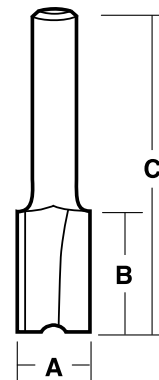

ROUTER BITS



2 Flute – Solid Carbide Insert

- For all general purpose routing, grooving, rebating.
- For longer life in routing abrasive type materials

Product Group	Discount Group
R508	Z0912

Part No.	A		B		C		Shank		Barcode
	inch	mm	inch	mm	inch	mm	inch	mm	
T1406 M	15/64	6	5/8	15.9	2-3/4	70	1/2	12.7	9314350003668
T1408	1/4	6.35	5/8	15.9	2-3/4	70	1/2	12.7	9314350003675
T1410	5/16	7.9	3/4	19	2-7/8	73	1/2	12.7	9314350003682
T1408 M	5/16	8	3/4	19	2-7/8	73	1/2	12.7	9314350003699

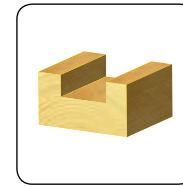
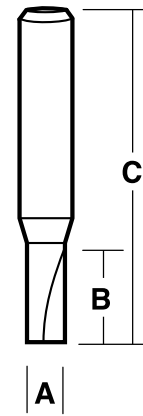

2 Flute – Carbide Tipped

- For all general purpose routing, grooving, rebating.
- For longer life in routing abrasive type materials

Product Group	Discount Group
R509	Z0904

Part No.	A		B		C		Shank		Barcode
	inch	mm	inch	mm	inch	mm	inch	mm	
T1409 M	23/64	9	1	25.4	2-3/4	70	1/2	12.7	9314350000209
T1412	3/8	9.5	1	25.4	2-3/4	70	1/2	12.7	9314350003705
T1410 M	25/64	10	1	25.4	2-3/4	70	1/2	12.7	9314350003712
T1411 M	7/16	11	1	25.4	2-3/4	70	1/2	12.7	9314350000216
T1414	7/16	11.1	1	25.4	2-3/4	70	1/2	12.7	9314350000223
T1412 M	15/32	12	1	25.4	2-3/4	70	1/2	12.7	9314350003729
TX 1412 M	15/32	12	1-1/4	31.8	3	76	1/2	12.7	9314350009226
T1416	1/2	12.7	1-1/4	31.8	3	76	1/2	12.7	9314350003736
TX 1416	1/2	12.7	2	50.8	3-3/4	95	1/2	12.7	9314350003743
T1413 M	33/64	13	1-1/4	31.8	3	76	1/2	12.7	9314350003750
TX 1413 M	33/64	13	2	50.8	3-3/4	95	1/2	12.7	9314350003767
T1414 M	35/64	14	1-1/4	31.8	3	76	1/2	12.7	9314350000230
T1418	9/16	14.3	1-1/4	31.8	3	76	1/2	12.7	9314350000247
T1415 M	19/32	15	1-1/2	38.1	3-1/4	82	1/2	12.7	9314350000254
T1420	5/8	15.9	1-1/2	38.1	3-1/4	82	1/2	12.7	9314350003774
TX 1420	5/8	15.9	2	50.8	3-3/4	95	1/2	12.7	9314350003781
T1416 M	5/8	16	1-1/2	38.1	3-1/4	82	1/2	12.7	9314350003798
TX 1416 M	5/8	16	2	50.8	3-3/4	95	1/2	12.7	9314350003804
T1416.5 M	21/32	16.5	1-1/2	38.1	3-1/4	82	1/2	12.7	9314350003811
T1417 M	43/64	17	1-1/2	38.1	3-1/4	82	1/2	12.7	9314350003828
T1422	11/16	17.5	1-1/2	38.1	3-1/4	82	1/2	12.7	9314350000261
T1418 M	45/64	18	1-1/2	38.1	3-1/4	82	1/2	12.7	9314350003835
TX 1418 M	45/64	18	2	50.8	3-3/4	95	1/2	12.7	9314350003842
T1418.5 M	-	18.5	1-1/2	38.1	3-1/4	82	1/2	12.7	9314350003859
T1419 M	3/4	19	1-1/2	38.1	3-1/4	82	1/2	12.7	9314350003866
TX 1419 M	3/4	19	2	50.8	3-3/4	95	1/2	12.7	9314350003873
T1424	3/4	19	1-1/2	38.1	3-1/4	82	1/2	12.7	9314350003880
TX 1424	3/4	19	2	50.8	3-3/4	95	1/2	12.7	9314350003897
T1419.5 M	49/64	19.5	1-1/2	38.1	3-1/4	82	1/2	12.7	9314350003903
T1420 M	-	20	1-1/2	38.1	3-1/4	82	1/2	12.7	9314350003910
T1426	13/16	20.6	1-1/2	38.1	3-1/4	82	1/2	12.7	9314350003927
T1428	7/8	22.2	1-1/2	38.1	3-1/4	82	1/2	12.7	9314350003934

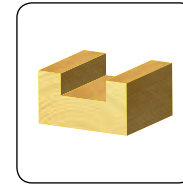
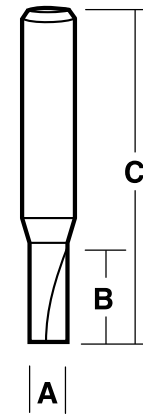

Part No.	A		B		C		Shank		Barcode
	inch	mm	inch	mm	inch	mm	inch	mm	
T1425 M	63/64	25	1-1/2	38.1	3-1/4	82	1/2	12.7	9314350003941
T1432	1	25.4	1-1/2	38.1	3-1/4	82	1/2	12.7	9314350003958
T1436	1-1/8	28.6	1-1/4	31.8	3	76	1/2	12.7	9314350000278
T1432 M	-	32	1-1/4	31.8	3	76	1/2	12.7	9314350003965
T1435 M	1-3/8	35	1-1/4	31.8	3	76	1/2	12.7	9314350000285
T1448	1-1/2	38.1	1-1/4	31.8	3	76	1/2	12.7	9314350003972
T1452	1-5/8	41.3	1-1/4	31.8	3	76	1/2	12.7	9314350000292
T1456	1-3/4	44.4	1-1/4	31.8	3	76	1/2	12.7	9314350000308
T1460	1-7/8	47.6	1-1/4	31.8	3	76	1/2	12.7	9314350000315
T1464	2	50.8	1-1/4	31.8	3	76	1/2	12.7	9314350000322

2 Flute - End Cutting - Carbide Tipped

- For plunge cutting deep or repetitive holes
- Also for normal groove, trim and rebate routing

Product Group R510
Discount Group Z0904

Part No.	A		B		C		Shank		Barcode
	inch	mm	inch	mm	inch	mm	inch	mm	
T1410 ME/C	25/64	10	1	25.4	2-3/4	70	1/2	12.7	9314350000346
T1413 ME/C	33/64	13	1-1/4	31.8	3	76	1/2	12.7	9314350000353
T1416 ME/C	5/8	16	1-1/2	38.1	3-1/4	82	1/2	12.7	9314350000360
T1418 ME/C	45/64	18	1-1/2	38.1	3-1/4	82	1/2	12.7	9314350000377
T1419 ME/C	3/4	19	1-1/2	38.1	3-1/4	82	1/2	12.7	9314350000384
T1425 ME/C	63/64	25	1-1/2	38.1	3-1/4	82	1/2	12.7	9314350000391
T1432 MEC	-	32	1-1/4	31.8	3	76	1/2	12.7	9314350000407

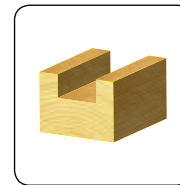
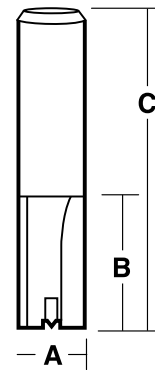

Straight Bit with Down Shear

- Reduces top edge breakout
- Ideal for veneered and laminated boards

Product Group R511
Discount Group Z0904

Part No.	A		B		C		Shank		Barcode
	inch	mm	inch	mm	inch	mm	inch	mm	
TSH1424	3/4	19	1-1/2	38.1	3-1/4	82	1/2	12.7	9314350015166
TSHX1424	3/4	19	1-61/64	50	3-23/37	94.5	1/2	12.7	9314350015197

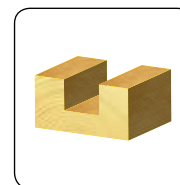
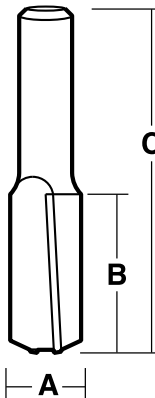

Single Flute - Rip & Slotter Bit - Solid Carbide

- A slotting and fast cutting roughing bit

Product Group R512 **Discount Group** Z0912

Part No.	A		B		C		Shank		Barcode
	inch	mm	inch	mm	inch	mm	inch	mm	
T 803-509	1/4	6.35	3/8	9.5	1-1/2	38.1	1/4	6.35	9314350000339

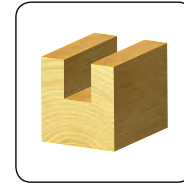
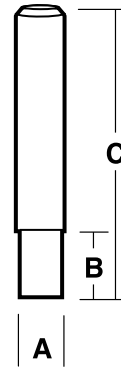

2 Flute - Slot Mortise Bit - End Cutting with Chip Breaker - Solid Carbide

- A long series bit for slot mortise joints*
- These bits are not guaranteed against breakage

Product Group R513 **Discount Group** Z0912

Part No.	A		B		C		Shank		Barcode
	inch	mm	inch	mm	inch	mm	inch	mm	
TSM 1408 M	5/16	8	1-1/2	38.1	3-5/8	92	1/2	12.7	9314350000674
TSM 1409.5 M	3/8	9.5	1-1/2	38.1	3-5/8	92	1/2	12.7	9314350000681

*Due to the extreme length of these bits they should be used in a table mounted routing machine only.

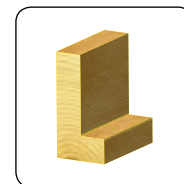
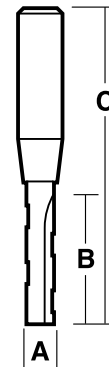

2 Flute - Slot Mortise Bit - End Cutting with Chip Breaker - Carbide Tipped

- A long series bit for slot mortise joints*
- These bits are not guaranteed against breakage

Product Group R514 **Discount Group** Z0904

Part No.	A		B		C		Shank		Barcode
	inch	mm	inch	mm	inch	mm	inch	mm	
TSM 1413 M	33/64	13	2	50.8	3-3/4	95	1/2	12.7	9314350000698

*Due to the extreme length of these bits they should be used in a table mounted routing machine only.

2 Flute - Lock Mortise Cutter - Carbide Tipped

- Standard bits have a 12/32 NEF thread to suit the Stanley machine
- Bits marked UNF fit the Porter Cable Machine eg. Archer

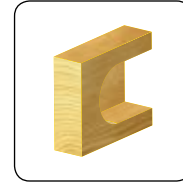
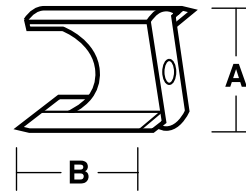

Product Group	Discount Group
R516	Z0904

Part No.	A		B		Thread	Barcode
	inch	mm	inch	mm		
TLM10	5/8	15.9	3/4	19	12/32 NEF	9314350000483
TLM12	3/4	19	3/4	19	12/32 NEF	9314350000490
TLM12 UNF	3/4	19	0.59	15	1/4 UNF	9314350012943
TLM13 UNF	13/16	20.6	0.59	15	1/4 UNF	9314350019683
TLM14	7/8	22.2	1	25.4	12/32 NEF	9314350000506
TLM14 UNF	7/8	22.2	0.59	15	1/4 UNF	9314350012950
TLM16	1	25.4	1	25.4	12/32 NEF	9314350000513
TLM16 UNF	1	25.4	0.59	15	1/4 UNF	9314350012967

Extension arbors - 96mm long are available to suit both NEF (TA22) and UNF (TA24) threads. TA22 for NEF, TA24 for UNF (see page 173).

2 Flute - Hinge Mortise Bit

- Can be used as a fast cutting stair tread bit or making mortises from edge of work

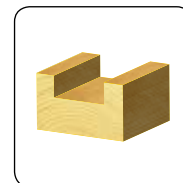
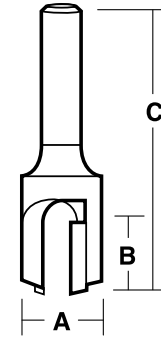

Product Group	Discount Group
R517	Z0906

Part No.	A		B		C		Shank		Barcode
	inch	mm	inch	mm	inch	mm	inch	mm	
HIGH SPEED STEEL 1/4" SHANK									
H 2016	1/2	12.7	13/32	10.3	-	50	1/4	6.35	9314350000704

Product Group	Discount Group
R518	Z0904

Part No.	A		B		C		Shank		Barcode
	inch	mm	inch	mm	inch	mm	inch	mm	
CARBIDE TIPPED 1/4" SHANK									
T 2016	1/2	12.7	13/32	10.3	-	42	1/4	6.35	9314350000711
CARBIDE TIPPED 1/2" SHANK									
T 1622 1/2	11/16	17.5	3/4	19	2-1/2	63.5	1/2	12.7	9314350000728
T 1624 1/2	3/4	19	3/4	19	2-1/2	63.5	1/2	12.7	9314350000735
T 1626 1/2	13/16	20.6	3/4	19	2-1/2	63.5	1/2	12.7	9314350000742
T 1628 1/2	7/8	22.2	3/4	19	2-1/2	63.5	1/2	12.7	9314350000759

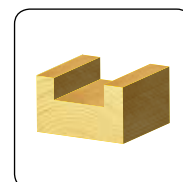
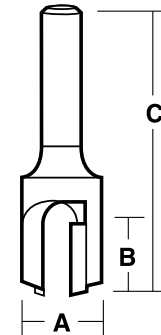

ROUTER BITS



2 Flute – For Scheer Routers – Solid Carbide

- 10mm internal thread

Product Group R519 **Discount Group** Z0904

Part No.	A		B		C		Shank		Barcode
	inch	mm	inch	mm	inch	mm	inch	mm	
TFRNA 8	1/4	6.35	5/8	15.9	2-3/16	55	-	-	9314350000414

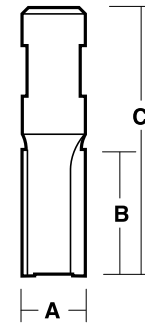

TFRNA 8

2 Flute – For Scheer Routers – Carbide Tipped

- 10mm internal thread

Product Group R520 **Discount Group** Z0904

Part No.	A		B		C		Shank		Barcode
	inch	mm	inch	mm	inch	mm	inch	mm	
TFRNA 12	3/8	9.5	3/4	19	2-3/16	55	-	-	9314350000421
TFRNA 16	1/2	12.7	3/4	19	2-3/16	55	-	-	9314350000438
TFRNA 20	5/8	16	1-1/4	31.8	2-3/8	60	-	-	9314350000445
TFRNA 24	3/4	19	1-1/4	31.8	2-3/8	60	-	-	9314350000452

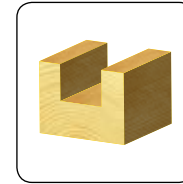

TFRNA 12

Staggered Tip Bit – Solid Carbide Insert

- A fast cutting roughing bit for heavy stock removal
- Staggered tips provide high chip clearance

Product Group R521 **Discount Group** Z0912

Part No.	A		B		C		Shank		Barcode
	inch	mm	inch	mm	inch	mm	inch	mm	
TST1409.5 M	3/8	9.5	1-1/2	38.1	3-5/8	92	1/2	12.7	9314350000643

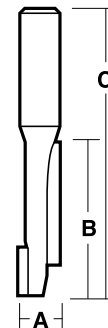

TST 1409.5 M

Staggered Tip Bit – Carbide Tipped

- A fast cutting roughing bit for heavy stock removal
- Staggered tips provide high chip clearance

Product Group R522 **Discount Group** Z0912

Part No.	A		B		C		Shank		Barcode
	inch	mm	inch	mm	inch	mm	inch	mm	
TST1413 M	33/64	13	1-3/4	44.5	3-1/2	89	1/2	12.7	9314350000650
TSTX1413 M	33/64	13	2-1/4	57.1	4	102	1/2	12.7	9314350000667

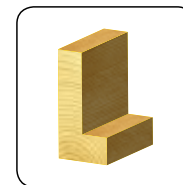

TST 1413 M

Single Flute - Flush Trimming Bit with Pilot - Carbide Tipped

- For edge trimming of laminated sink tops
- General purpose flush trimming

Product Group R523 **Discount Group** Z0904

Part No.	A		B		C		Shank		Barcode
	inch	mm	inch	mm	inch	mm	inch	mm	
T1910	5/16	8	13/16	20.6	2-3/8	65	1/4	6.35	9314350000858

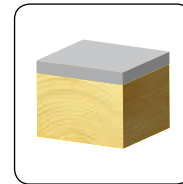
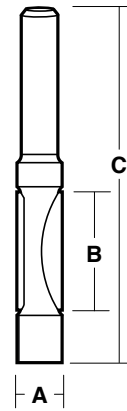

ROUTER BITS

2 Flute - Flush Trimming Bit with Pilot - Carbide Tipped

- For edge trimming of laminated sink tops
- General purpose flush trimming

Product Group R524 **Discount Group** Z0904

Part No.	A		B		C		Shank		Barcode
	inch	mm	inch	mm	inch	mm	inch	mm	
T1910-2	5/16	8	13/16	20.6	2-3/8	63	1/4	6.35	9314350000889

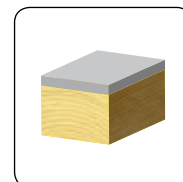
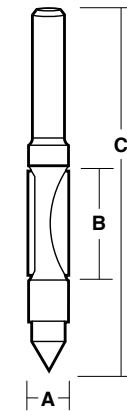

Single Flute - Combination Flush Trimming Bit with Pilot & Drill Point - HSS

- This bit drills it's own hole for blind routing in plywood and soft metals
- Eliminates fitting edges at window and floor openings

Product Group R525 **Discount Group** Z0906

Part No.	A		B		C		Shank		Barcode
	inch	mm	inch	mm	inch	mm	inch	mm	
H1508	1/4	6.35	3/4	19	2-3/8	60	1/4	6.35	9314350000933
H1512 3/8	3/8	9.5	7/8	22.2	2-5/8	67	3/8	9.53	9314350000957
H1516 1/2	1/2	12.7	1-1/8	28.6	3-5/8	92	1/2	12.7	9314350000964

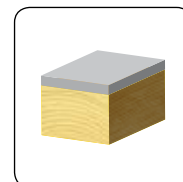
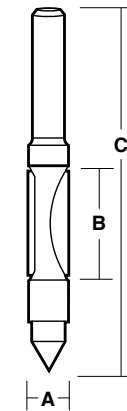

Single Flute - Combination Flush Trimming Bit with Pilot & Drill Point - Solid Carbide

- This bit drills it's own hole for blind routing in plywood and soft metals
- Eliminates fitting edges at window and floor openings

Product Group R526 **Discount Group** Z0912

Part No.	A		B		C		Shank		Barcode
	inch	mm	inch	mm	inch	mm	inch	mm	
T1508	1/4	6.35	25/32	20	2-1/2	63.5	1/4	6.35	9314350000971

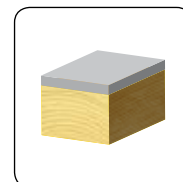
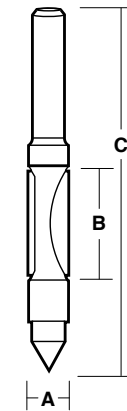

Single Flute - Combination Flush Trimming Bit with Pilot & Drill Point - Carbide Tipped

- This bit drills it's own hole for blind routing in plywood and soft metals
- Eliminates fitting edges at window and floor openings

Product Group R527 Discount Group Z0904

Part No.	A		B		C		Shank		Barcode
	inch	mm	inch	mm	inch	mm	inch	mm	
T1510	5/16	8	13/16	20.6	2-61/64	75	1/4	6.35	9314350000988
T1512 3/8	3/8	9.5	1	25.4	3-3/16	81	3/8	9.53	9314350000995
T1516 1/2	1/2	12.7	1	25.4	3-5/8	92	1/2	12.7	9314350001008

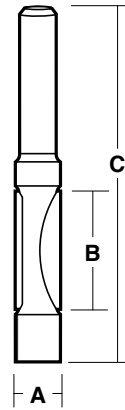

2 Flute - Combination Flush Trimming Bit with Pilot & Drill Point - Carbide Tipped

- This bit drills it's own hole for blind routing in plywood and soft metals
- Eliminates fitting edges at window and floor openings

Product Group R528 Discount Group Z0904

Part No.	A		B		C		Shank		Barcode
	inch	mm	inch	mm	inch	mm	inch	mm	
T1510 - 2	5/16	8	13/16	20.6	2-3/4	70	1/4	6.35	9314350001015

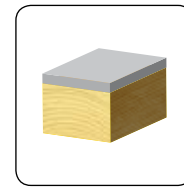

Spiral Down Cut - Combination Flush Trimming Bit with Pilot & Drill Point - HSS

- Used extensively in the caravan repair and manufacturing industries
- For drilling and trimming sheet aluminium, aluminium composite panel etc

Product Group R529 Discount Group Z0906

Part No.	A		B		C		Shank		Barcode
	inch	mm	inch	mm	inch	mm	inch	mm	
HSF1508	1/4	6.35	3/4	19	2-3/4	70	1/4	6.35	9314350001084
HSF1512 3/8	3/8	9.5	25/32	20	3	76	3/8	9.53	9314350001091
HSF1516 1/2	1/2	12.7	1-3/4	44.4	4-1/2	115	1/2	12.7	9314350001107

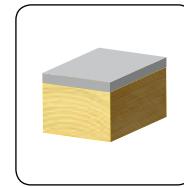
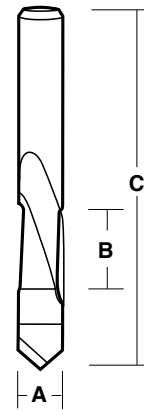

Slotting Cutter Assemblies – Solid Carbide

- Solid carbide cutters give great rigidity for thin slotting cuts
- Twelve teeth
- Suitable for a wide range of materials

Product Group	Discount Group
R530	Z0912

Part No.	A		B		C		Arbor No.	Shank		Barcode
	inch	mm	inch	mm	inch	mm		inch	mm	
TA 900-1.2 M	1-1/4	31.8	3/64	1.2	1-5/8	41	TA 11	1/4	6.35	9314350001503
TA 900-1.6 M	1-1/4	31.8	1/16	1.6	1-5/8	41	TA 11	1/4	6.35	9314350001510
T 900-1.2 M	1-1/4	31.8	3/64	1.2	Cutter Only		-	-	-	9314350009875
T 900-1.6 M	1-1/4	31.8	1/16	1.6	Cutter Only		-	-	-	9314350009882

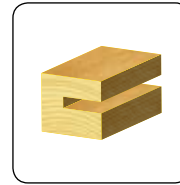
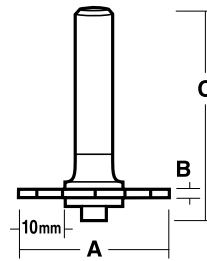

Slotting Cutter Assemblies with Ball Bearing Guide – Solid Carbide

- Solid carbide cutters give great rigidity for thin slotting cuts
- Twelve teeth
- Suitable for a wide range of materials

Product Group	Discount Group
R531	Z0912

Part No.	A		B		C		Arbor No.	Shank		Barcode
	inch	mm	inch	mm	inch	mm		inch	mm	
TA 900-1.2 MB	1-1/4	31.8	3/64	1.2	2-3/32	53	TA 10	1/4	6.35	9314350001527
TA 900-1.6 MB	1-1/4	31.8	1/16	1.6	2-3/32	53	TA 10	1/4	6.35	9314350001534

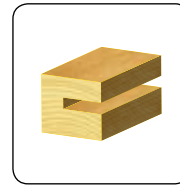
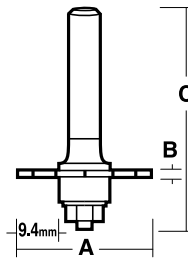

Replacement bearing TB11

ROUTER BITS



2 Flute - Flush Trimming Bit with Ball Bearing Guide - Carbide Tipped

- Fast, smooth and accurate trimming cuts for laminates and template work

Product Group R534 **Discount Group** Z0904

Part No.	A		B		C		Bearing No.	Shank		Barcode
	inch	mm	inch	mm	inch	mm		inch	mm	
T 8008 B	1/4	6.35	1	25.4	2-3/8	60	TB 6	1/4	6.35	9314350009240
T 8012 B	3/8	9.5	1	25.4	2-5/8	63.5	TB 9	1/4	6.35	9314350004009
TS 8012 B	3/8	9.5	1/2	12.7	1-57/64	48	TB 9	1/4	6.35	9314350017832
TS 8016 B	1/2	12.7	5/8	15.9	2-1/4	57.1	TB 11	1/4	6.35	9314350004016
T 8016 B	1/2	12.7	1	25.4	2-1/2	67	TB 11	1/4	6.35	9314350004023
T 8016 B 1/2	1/2	12.7	1	25.4	3-1/8	79	TB 11	1/2	12.7	9314350004030
TX 8016 B 1/2	1/2	12.7	1-1/2	38.1	3-3/8	86	TB 11	1/2	12.7	9314350004047
TXX 8016 B 1/2	1/2	12.7	2	50.8	3-7/8	98	TB 11	1/2	12.7	9314350004054
T 8020 B	5/8	15.9	1	25.4	2-5/8	67	TB 14	1/4	6.35	9314350004061
T 8020 B 1/2	5/8	15.9	1	25.4	3-1/8	79	TB 14	1/2	12.7	9314350004078
T 8028 B 1/2	0.866	22	1	25.4	3-3/8	86	TB 12	1/2	12.7	9314350004085
TX 8028 B 1/2	0.866	22	1-1/2	38.1	3-3/4	95	TB 12	1/2	12.7	9314350012929

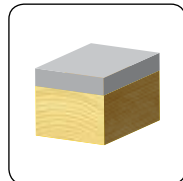
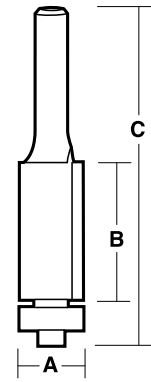

Diamond (PCD) Tipped Flush Trimming Bit

- Made with Polycrystalline Diamond PCD Tips
- PCD Tips keeps cutting edge extremely sharp for longer life than tungsten carbide tips
- Excellent for extremely hard laminates

Product Group R535 **Discount Group** Z0914

Part No.	A		B		C		Bearing No.	Shank		Barcode
	inch	mm	inch	mm	inch	mm		inch	mm	
DIATR S 8012 B	3/8	9.5	1/2	12.7	2-3/32	53.2	TB9	1/4	6.35	9314350025592
DIATR S 8016 B	1/2	12.7	5/8	15.9	2-7/32	56.4	TB11	1/4	6.35	9314350025608
DIATR S 8016 B 1/2	1/2	12.7	5/8	15.9	2-13/16	71.4	TB11	1/2	12.7	9314350025615

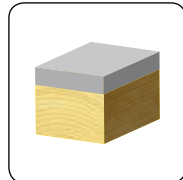
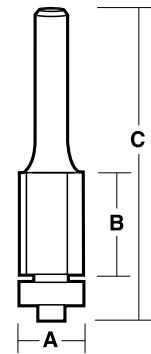

Flush Trimming Bit with Down Shear - Carbide Tipped

- For minimal chipping and superior finish
- Minimises delamination on top edge

Product Group R536 **Discount Group** Z0904

Part No.	A		B		C		Bearing No.	Shank		Barcode
	inch	mm	inch	mm	inch	mm		inch	mm	
TSH 8024 B 1/2	3/4	19	1-1/2	38.1	3-39/64	91.7	TB 16	1/2	12.7	9314350015173
TSHX 8024 B 1/2	3/4	19	1-61/64	50	4	101.6	TB 16	1/2	12.7	9314350015203

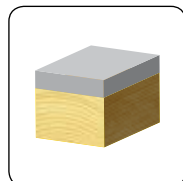
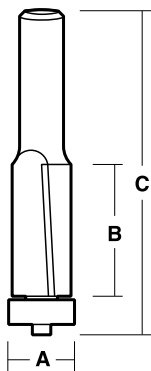

2 Flute - Overhang Trimming Bit with Ball Bearing Guide - Carbide Tipped

- Leaves a 1/8" overhang so that the final flush trimming cut is light, leaving the smoothest finish

Product Group R539 Discount Group Z0904

Part No.	A		B		C		Shank		Barcode
	inch	mm	inch	mm	inch	mm	inch	mm	
TO 8012 B	3/8	9.5	1	25.4	2-3/4	70	1/4	6.35	9314350001381

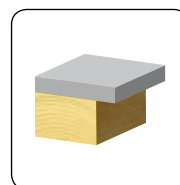
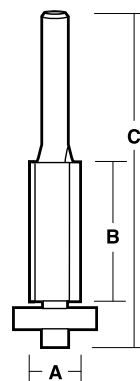

2 Flute - Flush Trimming Bit with Double Ball Bearing Guide - Carbide Tipped

- For template work in softer timbers.
- Double the surface area to ensure template surface is not damaged.

Product Group R537 Discount Group Z0904

Part No.	A		B		C		Bearing No.	Shank		Barcode
	inch	mm	inch	mm	inch	mm		inch	mm	
T 8012 BB	3/8	9.5	1	25.4	2-3/4	70	TB 9	1/4	6.35	9314350004092
TS 8012 BB	3/8	9.5	1/2	12.7	2-9/64	54.5	TB 9	1/4	6.35	93143500017849
TS 8016 BB	1/2	12.7	5/8	15.9	2-3/8	60	TB 11	1/4	6.35	93143500004108
T 8016 BB	1/2	12.7	1	25.4	2-3/4	70	TB 11	1/4	6.35	93143500004115
T 8016 BB 1/2	1/2	12.7	1	25.4	3-3/8	86	TB 11	1/2	12.7	93143500004122
TX 8016 BB 1/2	1/2	12.7	1-1/2	38.1	3-7/8	98	TB 11	1/2	12.7	93143500004139
TXX 8016 BB 1/2	1/2	12.7	2	50.8	4-1/4	108	TB 11	1/2	12.7	93143500004146
T 8020 BB	5/8	15.9	1	25.4	3	76	TB 14	1/4	6.35	93143500004153
T 8020 BB 1/2	5/8	15.9	1	25.4	3-3/8	86	TB 14	1/2	12.7	93143500004160
T 8028 BB 1/2	0.866	22	1	25.4	3-1/2	89	TB 12	1/2	12.7	93143500004177
TX 8028 BB 1/2	0.866	22	1-1/2	38.1	4-5/32	105	TB 12	1/2	12.7	93143500014640

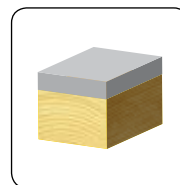
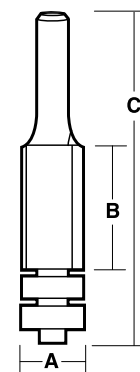

2 Flute - Flush Trimming Bit - Dual Bearing - Carbide Tipped

- Designed for trimming and template work
- Top and bottom bearings can be used for a variety of trimming applications.
- Can utilise top bearing, bottom bearing or both

Product Group R538 Discount Group Z0904

Part No.	A		B		C		End Bearing No.	Centre Bearing No.	Shank		Barcode
	inch	mm	inch	mm	inch	mm			inch	mm	
T 8216 DB	1/2	12.7	1	25.4	2-3/4	69.9	TB 11	TB 7	1/4	6.35	93143500025684
T 8224 DB 1/2	3/4	19	1-1/2	38.1	4-11/64	105.9	TB 16	TB 4	1/2	12.7	93143500025691

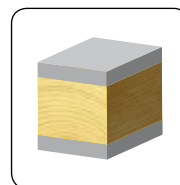
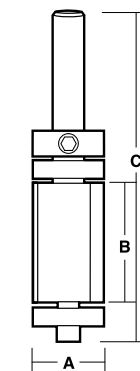

2 Flute - Inverted Flush Trimming Bit with Ball Bearing Guide - Carbide Tipped

- For copy work where the template is between the work piece and the router

Product Group	Discount Group
R540	Z0904

Part No.	A		B		C		Bearing No.	Retaining Ring	Shank		Barcode
	inch	mm	inch	mm	inch	mm			inch	mm	
T 8212 B	3/8	9.5	3/4	19	2-11/64	55	TB 2	Circlip	1/4	6.35	9314350017856
T 8216 B	1/2	12.7	3/4	19	2-11/64	55	TB 7	TZR 1	1/4	6.35	9314350010819
T 8220 B	5/8	15.9	3/4	19	2-11/64	55	TB 14	TZR 1	1/4	6.35	9314350004276
T 8224 B 1/2	3/4	19	1-1/2	38.1	3-5/8	92.1	TB 4	TZR 3	1/2	12.7	9314350014626
TX 8224 B 1/2	3/4	19	2	50.8	4-5/32	105.6	TB 4	TZR 3	1/2	12.7	9314350014633
T 8236 B 1/2	1-1/8	28.6	1-1/2	38.1	3-1/3	89	TB 18	TZR 3	1/2	12.7	9314350009257

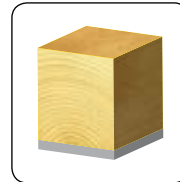
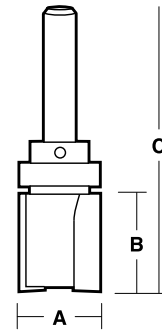

Inverted Flush Trimming Bit with Down Shear - Carbide Tipped

- Downward cutting action helps prevent delamination of veneers, laminates etc
- Useful when cutting soft, splintery timbers
- Cost effective alternative to down cut spirals

Product Group	Discount Group
R541	Z0904

Part No.	A		B		C		Bearing No.	Shank		Barcode
	inch	mm	inch	mm	inch	mm		inch	mm	
TSH 8224 B 1/2	3/4	19	1-1/2	38.1	3-39/64	91.7	TB 4	1/2	12.7	9314350015180
TSHX 8224 B 1/2	3/4	19	1-61/64	50	4	101.6	TB 4	1/2	12.7	9314350015210

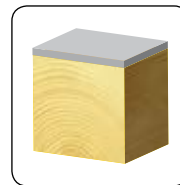
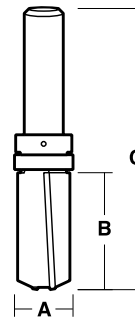

Spiral Flute Bit with Bearings - Up Cut - Solid Carbide

- Ideal for template work where a superior finish is required
- Up cut spiral provides an upward shear angle
- Can be used for an inverted workpiece when template is bottom mounted
- Excellent for use on different timbers, laminates, and some composites etc
- Helps to minimise chipping, splintering and furry edge finish
- Recommended for guitar timbers and box making timbers

Product Group	Discount Group
R542	Z0912

Part No.	A		B		C		Bearing No.	Shank		Barcode
	inch	mm	inch	mm	inch	mm		inch	mm	
TSRW 12 BB 3/8	3/8	9.5	1	25.4	3	76.2	TB9	3/8	9.53	9314350020047
TSRW 16 BB 1/2	1/2	12.7	1	25.4	3 5/8	92.1	TB11	1/2	12.7	9314350020054
TXSRW 16 BB 1/2	1/2	12.7	1 1/2	38.1	4	101.6	TB11	1/2	12.7	9314350020061
TXXSRW 16 BB 1/2	1/2	12.7	2	50.8	4 1/2	114.3	TB11	1/2	12.7	9314350020078

Up Cut

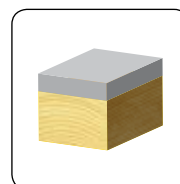

Product Group	Discount Group
R940	Z0912

Part No.	A		B		C		Bearing No.	Shank		Barcode
	inch	mm	inch	mm	inch	mm		inch	mm	
TSLW 12 BB 3/8	3/8	9.5	1	25.4	3	76.2	TB9	3/8	9.53	9314350020085
TSLW 16 BB 1/2	1/2	12.7	1	25.4	3 5/8	92.1	TB11	1/2	12.7	9314350020092
TXSLW 16 BB 1/2	1/2	12.7	1 1/2	38.1	4	101.6	TB11	1/2	12.7	9314350020108
TXXSLW 16 BB 1/2	1/2	12.7	2	50.8	4 1/2	114.3	TB11	1/2	12.7	9314350020078

Down Cut

2 Flute - Combination Flush & Bevel Trimming Bit with Ball Bearing Guide - Carbide Tipped

- Bit can be adjusted for either flush or bevel trim

Product Group	Discount Group
R543	Z0904

Part No.	A		B		C		Bevel	Shank		Barcode
	inch	mm	inch	mm	inch	mm		inch	mm	
T 9122 B	3/4	19	0.58	14.7	2-3/16	55	22°	1/4	6.35	9314350004252
T 9130 B	7/8	22.2	0.58	14.7	2-3/16	55	30°	1/4	6.35	9314350004269

Replacement bearing TB11

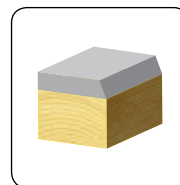
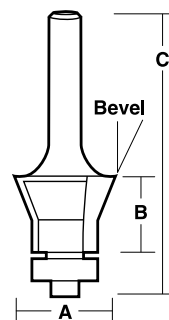

2 Flute - Handyman Range with Ball Bearing Guide - Carbide Tipped

- An effective range of trimming bits ideal for small routers

Product Group	Discount Group
R544	Z0904

Part No.	A		B		C		Shank		Barcode
	inch	mm	inch	mm	inch	mm	inch	mm	
T 192.00 B	1/2	12.7	1/4	6.35	1-3/4	44.4	1/4	6.35	9314350004184
T 192.22 B	0.697	17.7	1/4	6.35	1-3/4	44.4	1/4	6.35	9314350004191
T 192.30 B	0.784	19.3	1/4	6.35	1-3/4	44.4	1/4	6.35	9314350004207

Replacement bearing TB11

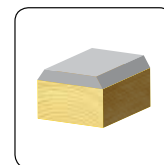
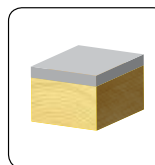
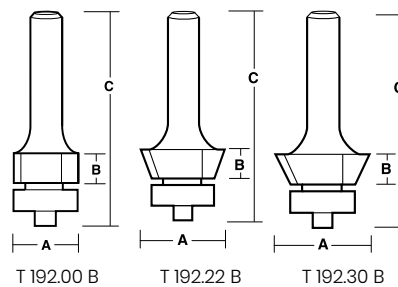

3 Flute - Professional Range - Flush Trimming Assembly - Solid Carbide

- For extra smooth trimming
- Assembly includes three flute cutter, bearing, arbor, spacers and nut

Product Group	Discount Group
R545	Z0904

Part No.	Bevel	Arbor No.	C		Shank		Barcode
			inch	mm	inch	mm	
TA 193.00 B	Flush	TA 9	2-3/8	60	1/4	6.35	9314350004214

3 Flute - Replacement Trimming Cutter - Solid Carbide

Product Group	Discount Group
R546	Z0904

Part No.	Bevel	A		Bore		Barcode
		inch	mm	inch	mm	
T 193.00	Flush	5/8	15.9	1/4	6.35	9314350004238

Replacement bearing TB14. For oversize bearing use TB16.

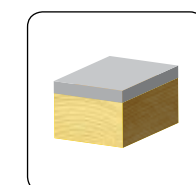
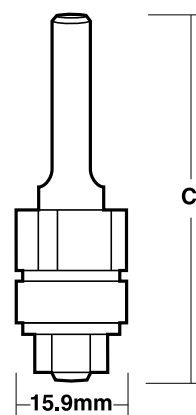

ROUTER BITS



4 Flute - Professional Range - Flush & Bevel Trimming Assemblies - Carbide Tipped

- Chatter-free trimming and superior finish at high feed rates
- Assembly includes 4 flute cutter, arbor, bearing nut and washer

Product Group R547 Discount Group Z0904

Part No.	Bevel	Arbor No.	B inch	B mm	C inch	C mm	Shank inch	Shank mm	Barcode
TA 194.00 B	Flush	TA 1	1/4	6.35	2-1/2	63.5	1/4	6.35	9314350001121
TA 194.00 B 1/2	Flush	TA 3	1/4	6.35	2-1/2	63.5	1/2	12.7	9314350001138
TA 194.15 B	15°	TA 1	1/4	6.35	2-1/2	63.5	1/4	6.35	9314350001145
TA 194.15 B 1/2	15°	TA 3	1/4	6.35	2-1/2	63.5	1/2	12.7	9314350001152
TA 194.25 B	25°	TA 1	1/4	6.35	2-1/2	63.5	1/4	6.35	9314350001169
TA 194.25 B 1/2	25°	TA 3	1/4	6.35	2-1/2	63.5	1/2	12.7	9314350001176
TA 194.45 B	45°	TA 1	1/4	6.35	2-1/2	63.5	1/4	6.35	9314350001183
TA 194.45 B 1/2	45°	TA 3	1/4	6.35	2-1/2	63.5	1/2	12.7	9314350001190

Replacement bearing TB12, Oversized bearing TB13

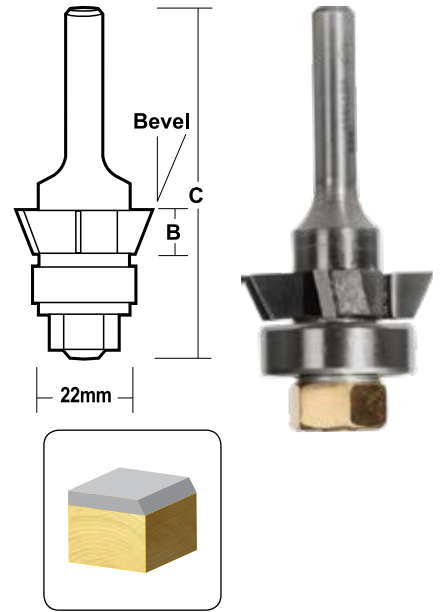

4 Flute - Replacement Trimming Cutter - Carbide Tipped

Product Group R548 Discount Group Z0904

Part No.	Bevel	A inch	A mm	Bore inch	Bore mm	Barcode
T 194.00	Flush	0.866	22	5/16	8	9314350001206
T 194.15	15°	1	25.4	5/16	8	9314350001213
T 194.25	25°	1-1/8	28.6	5/16	8	9314350001220
T 194.45	45°	1-3/8	35	5/16	8	9314350001237

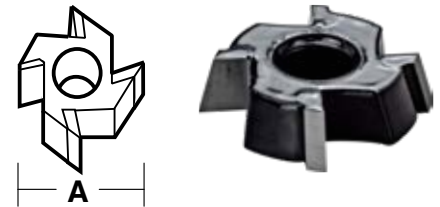

4 Flute - Double Flush & Bevel Trimming Assemblies - Carbide Tipped

- A time saving bit that will trim both sides of the board in one pass
- Washers enable cutters to be separated for correct trimming thickness

Product Group R550 Discount Group Z0904

Part No.	Bevel	Arbor No.	B inch	B mm	C inch	C mm	Shank inch	Shank mm	Barcode
TDA 194.00 B	FLUSH	TA 13	1/4	6.35	3	76	1/4	6.35	9314350001244
TDA 194.00 B 1/2	FLUSH	TA 14	1/4	6.35	3-1/4	82	1/2	12.7	9314350001251
TDA 194.15 B	15°	TA 13	1/4	6.35	3	76	1/4	6.35	9314350001268
TDA 194.15 B 1/2	15°	TA 14	1/4	6.35	3-1/4	82	1/2	12.7	9314350001275
TDA 194.25 B	25°	TA 13	1/4	6.35	3	76	1/4	6.35	9314350001282
TDA 194.25 B 1/2	25°	TA 14	1/4	6.35	3-1/4	82	1/2	12.7	9314350001299
TDA 194.45 B	45°	TA 13	1/4	6.35	3	76	1/4	6.35	9314350001305
TDA 194.45 B 1/2	45°	TA 14	1/4	6.35	3-1/4	82	1/2	12.7	9314350001312

Replacement bearing TB12

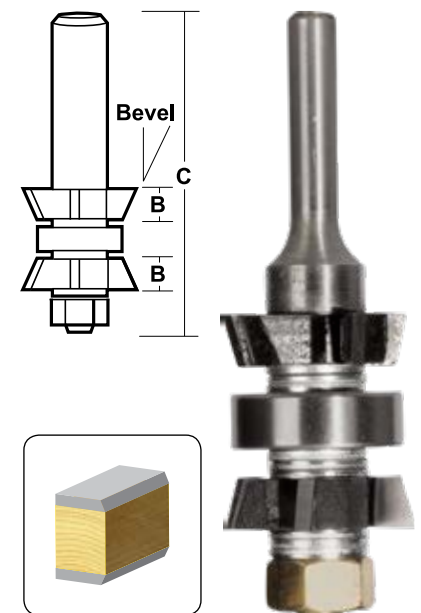

4 Flute - Replacement Trimming Cutter - Left Hand - Carbide Tipped

Product Group R551 Discount Group Z0904

Part No.	Bevel	A		Bore		Barcode
		inch	mm	inch	mm	
T194.15 LH	15°	1	25.4	5/16	8	9314350001329
T194.25 LH	25°	1-1/8	28.6	5/16	8	9314350001336
T194.45 LH	45°	1-3/8	35	5/16	8	9314350001343

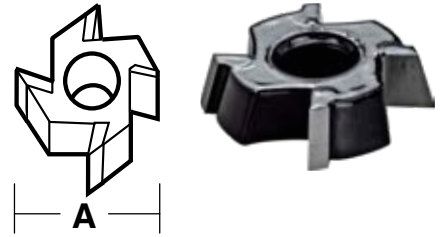

Single Flute - Combination Flush Trimming & Drilling Bit with Pilot & Drill Point - Solid Carbide

- Drills through surface laminate into pre-cut opening and trims edge square in one operation

Product Group R552 Discount Group Z0912

Part No.	A		B		C		Shank		Barcode
	inch	mm	inch	mm	inch	mm	inch	mm	
T703 - 507	1/4	6.35	5/8	16	1-1/2	38.1	1/4	6.35	9314350001367

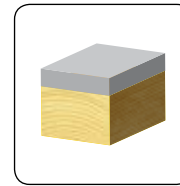
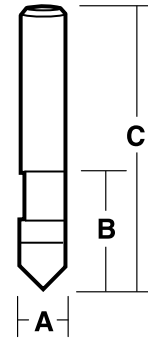

Single Flute with Pilot - 7° Bevel Trimming Bit - Solid Carbide

- Provides 7° bevel to trim the edge of plastic laminate surfaces
- Built in pilot eliminates the need for guide assembly or trimmer

Product Group R553 Discount Group Z0912

Part No.	A		B		C		Shank		Barcode
	inch	mm	inch	mm	inch	mm	inch	mm	
T403 - 501	3/16	4.8	1/2	12.7	1-1/2	38.1	1/4	6.35	9314350001374

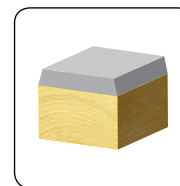
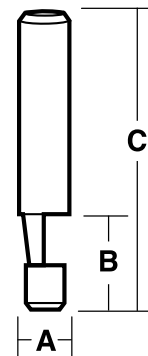

ROUTER BITS



Single Flute - Combination Flush & 7° Bevel Trimming Bit - Solid Carbide

- Provides 7° bevel or 0° square cut on the edge of plastic laminated surfaces

<i>Product Group</i>		<i>Discount Group</i>									
R554		Z0912									
Part No.	A		B		C		Shank		Barcode		
	inch	mm	inch	mm	inch	mm	inch	mm			
T2614	1/4	6.35	3/8	9.5	1-1/2	38.1	1/4	6.35	9314350004283		

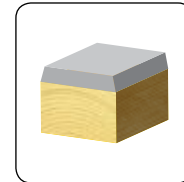
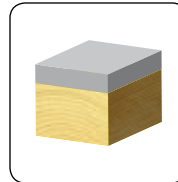
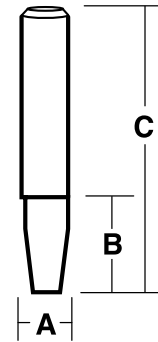

Single Flute - Combination Flush & 22° Bevel Trimming Bit - Solid Carbide

- Provides 22° bevel or 0° square cut on the edge of plastic laminated surfaces

<i>Product Group</i>		<i>Discount Group</i>									
R555		Z0912									
Part No.	A		B		C		Shank		Barcode		
	inch	mm	inch	mm	inch	mm	inch	mm			
TBD 22	1/4	6.35	1/2	12.7	1	25.4	1/4	6.35	9314350004290		
TBDX 22	1/4	6.35	1/2	12.7	1-1/2	38.1	1/4	6.35	9314350004306		

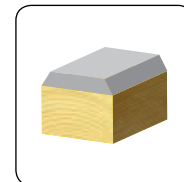
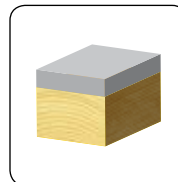
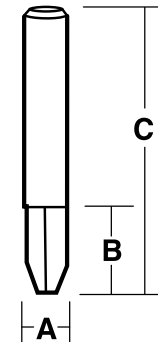

Single Flute with Pilot - Flush Trimming Bit - Solid Carbide

- Makes square trim edge cuts
- Built in pilot eliminates the need for guide assembly or trimmer

<i>Product Group</i>		<i>Discount Group</i>									
R556		Z0912									
Part No.	A		B		C		Shank		Barcode		
	inch	mm	inch	mm	inch	mm	inch	mm			
T303-500	1/4	6.35	1/4	6.35	1-1/2	38.1	1/4	6.35	9314350001350		

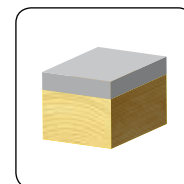
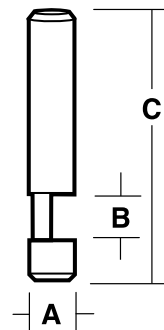

2 Flute - Combination Flush & 22° Bevel Trimming Bit - Carbide Tipped

- Provides a 22° or 0° straight cut on the edge of plastic or laminates surfaces

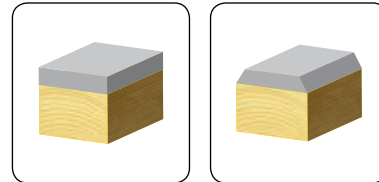
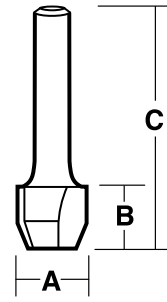

Product Group R557 Discount Group Z0904

Part No.	A		B		C		Shank		Barcode
	inch	mm	inch	mm	inch	mm	inch	mm	
T 2622	15/32	12	7/16	11	1-5/8	41	1/4	6.35	9314350004313
TX 2622	9/16	14.3	3/4	19	-	51	1/4	6.35	9314350010741

2 Flute - 30° Bevel Trimming Bit - Carbide Tipped

- Provides a 30° bevel to trim the edge of plastic laminated surfaces

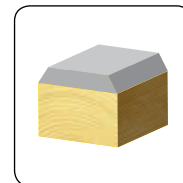
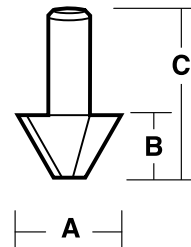

Product Group R558 Discount Group Z0904

Part No.	A		B		C		Shank		Barcode
	inch	mm	inch	mm	inch	mm	inch	mm	
TBD 30	5/8	15.9	3/8	9.5	1	25.4	1/4	6.35	9314350004320
TBDX 30	5/8	15.9	3/8	9.5	1-3/8	35	1/4	6.35	9314350004337

Edge Band Trim Bit - Carbide Tipped

- For use in edge banding machines
- Cutters are a left hand and right hand matched pair
- Round over edge profile

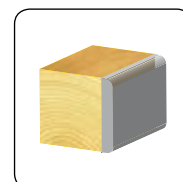
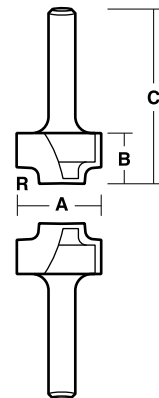

Product Group R559 Discount Group Z0904

Part No.	A		B		C		R Radius		Shank		Barcode
	inch	mm	inch	mm	inch	mm	inch	mm	inch	mm	
TLE 24	3/4	19	31/64	12.3	1-45/64	43.3	5/64	2.0	1/4	6.35	9314350015142
TLE 24 LH	3/4	19	31/64	12.3	1-45/64	43.3	5/64	2.0	1/4	6.35	9314350015159

15° Bevel - Edge Band Trim Bit - Carbide Tipped

- 15° bevel
- For use in edge banding machines
- Cutters are a left hand and right hand matched pair

Product Group	Discount Group
R560	Z0904

Part No.	A		B		C		Shank		Barcode
	inch	mm	inch	mm	inch	mm	inch	mm	
TEG15	1-17/64	32	33/64	13	1-1/2	38.1	1/4	6.35	9314350015104
TEG15 LH	1-17/64	32	33/64	13	1-1/2	38.1	1/4	6.35	9314350015111

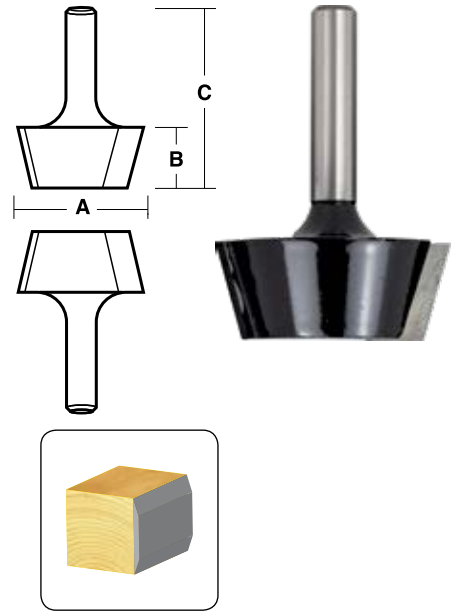

GROOVE FORMING BITS

2 Flute - Brookman Dovetail Bit - Carbide Tipped

- A bit specially designed to be used in the Brookman dovetailing machine

Product Group	Discount Group
R561	Z0904

Part No.	A		B		C		Bevel	Shank		Barcode
	inch	mm	inch	mm	inch	mm		inch	mm	
T100	0.520	13.2	9/16	14.3	2-1/4	57.1	10°	3/8	9.53	9314350000926

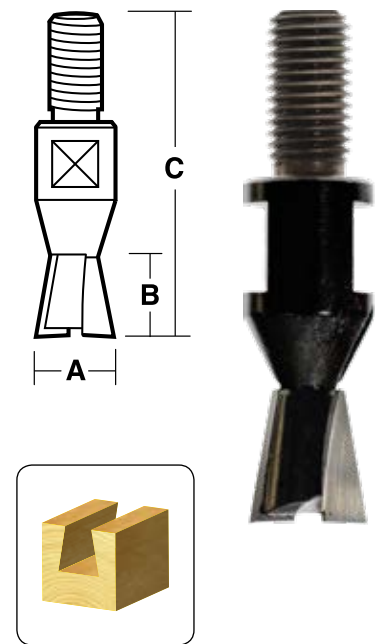

2 Flute - Dovetail Bit - HSS

- Fore dovetail joint, drawer fronts etc
- For quality minded craftsman

Product Group **Discount Group**
R562 Z0906

Part No.	A		B		C		Bevel	Shank		Barcode
	inch	mm	inch	mm	inch	mm		inch	mm	
HIGH SPEED STEEL										
H1012	9/32	7.1	-	9.5	1-5/8	41	5°	1/4	6.35	9314350000766
H1018	9/16	14.3	-	13.5	1-5/8	41	15°	1/4	6.35	9314350000773
H1018 1/2	9/16	14.3	-	13.5	2	50.8	15°	1/2	12.7	9314350000780

Product Group **Discount Group**
R563 Z0912

Part No.	A		B		C		Bevel	Shank		Barcode
	inch	mm	inch	mm	inch	mm		inch	mm	
SOLID CARBIDE										
T1012	9/32	7.1	-	9.5	1-1/2	38.1	5°	1/4	6.35	9314350000797

Product Group **Discount Group**
R564 Z0904

Part No.	A		B		C		Bevel	Shank		Barcode
	inch	mm	inch	mm	inch	mm		inch	mm	
CARBIDE TIPPED										
T1016	1/2	12.7	-	13.5	1-3/4	44.4	15°	1/4	6.35	9314350003989
T1018	9/16	14.3	-	13.5	1-3/4	44.4	15°	1/4	6.35	9314350003996
T1018 3/8	9/16	14.3	-	13.5	2-3/4	70	15°	3/8	9.53	9314350000803
T1018 10MM	9/16	14.3	-	13.5	2-3/4	70	15°	1/2	12.7	9314350000810
T1018 1/2	9/16	14.3	-	13.5	2-3/4	70	15°	1/2	12.7	9314350000827
T1019	19/32	15	-	12.7	1-3/4	44.4	15°	1/4	6.35	9314350009233
T1024 1/2	3/4	19	-	26	2-3/4	70	5°	1/2	12.7	9314350000834

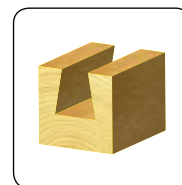
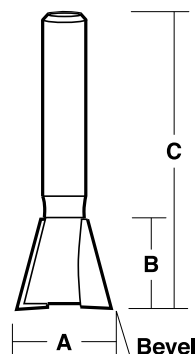

2 Flute - Dovetail "Gifkins" Bit - Carbide Tipped

- To suit 'Gifkins' dovetail jig
- For highly accurate dovetail joints (in conjunction with the Gifkins dovetail jig)
- Suitable for box making and all timbers

Product Group **Discount Group**
R565 Z0904

Part No.	A		B		C		Bevel	Retaining Ring	Shank		Barcode
	inch	mm	inch	mm	inch	mm			inch	mm	
TGAD 12	3/8	9.5	33/64	13	2-1/2	63.5	8°	TZR 4	1/4	6.35	9314350014343
TGBD 16 1/2	5/8	15.9	-	22	2-5/16	84	8°	TZR 3	1/2	12.7	9314350014374
TGAS 12	3/8	9.5	33/64	13	2-31/64	63	0°	TZR 4	1/4	6.35	9314350014336
TGBS 16 1/2	1/2	12.7	-	22	3-5/16	84	0°	TZR 3	1/2	12.7	9314350014350
TGHD 12	0.244	6.2	25/64	10	2-1/4	57.1	7°	TZR 4	1/4	6.35	9314350016941
TGHS 12	0.433	11	25/64	10	2-1/4	57.1	0°	TZR 4	1/4	6.35	9314350016958

Replacement bearings
- 1/4" Shank = TB 7
- 1/2" Shank = TB 4

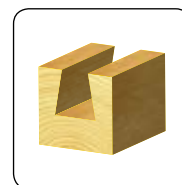
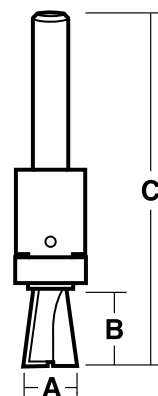

2 Flute - T-Cut Dovetail Bit with Ball Bearing Guide - Carbide Tipped

- Cuts dovetail joints with high precision and accuracy for fine furniture making
- Suits T-Cut dovetail jig
- Also suits many entry level dovetail jigs

Product Group		Discount Group								
R566		Z0904								
Part No.	A		B		C		Retaining Ring	Shank		Barcode
	inch	mm	inch	mm	inch	mm		inch	mm	
TB19149	-	14.9	-	10	-	46	TZR 1	1/4	6.35	9314350012196

Replacement bearing TB7

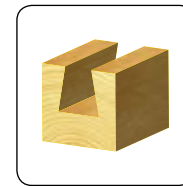
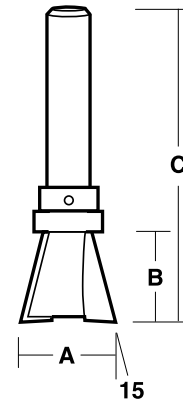

2 Flute - Dovetail "Leigh" Bit - Carbide Tipped

- To suit the 'Leigh' dovetail jig
- Produces precision joints

Product Group		Discount Group								
R567		Z0904								
Part No.	A		B		C		Bevel	Shank		Barcode
	inch	mm	inch	mm	inch	mm		inch	mm	
TL 70	3/8	9.5	1/2	12.7	2-3/8	60	8°	1/4	6.35	9314350008236
TL 80	1/2	12.7	13/16	20.6	2-3/4	70	8°	1/4	6.35	9314350008243
TL 90 1/2	11/16	17.4	1	25.4	2-7/8	73	8°	1/2	12.7	9314350008250
TL 100 1/2	13/16	20.6	1-1/4	31.8	3-1/8	79	8°	1/2	12.7	9314350008267
TL 120	1/2	12.7	1/2	12.7	2-3/8	60	14°	1/4	6.35	9314350008274
TL 140	5/16	8	1	25.4	2-7/8	73	0°	1/4	6.35	9314350008281
TL 150 1/2	7/16	11.1	1	25.4	3	76	0°	1/2	12.7	9314350008724
TL 160 1/2	1/2	12.7	1	25.4	3	76	0°	1/2	12.7	9314350008712

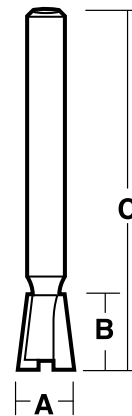

TL 120

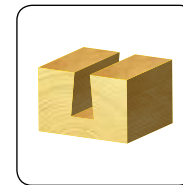

TL 140

2 Flute - Drawer Pull Bit - Carbide Tipped

- This bit will produce a hidden handle on drawers and cupboard doors

Part No.	A		B		C		R Radius		Shank		Barcode
	inch	mm	inch	mm	inch	mm	inch	mm	inch	mm	
TDC 16 1/2	1-3/4	44.4	1/2	12.7	2-1/2	63.5	1/2	12.7	1/2	12.7	9314350001022
TDC 20 1/2	2	50.8	9/16	14.3	2-9/16	65	9/16	14.3	1/2	12.7	9314350001039
TDC 24 1/2	2-1/4	57.1	3/4	19	2-5/8	67	3/4	19	1/2	12.7	9314350001046

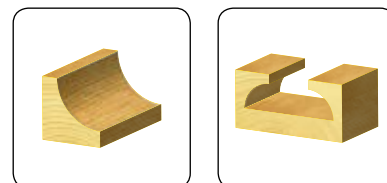
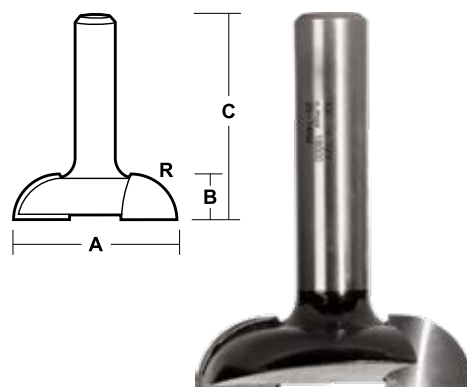

2 Flute - Drawer Pull Bit - Carbide Tipped

- For recessed handles on drawers or cupboard doors
- Decorative and functional applications

Part No.	A		B		C		Shank		Barcode
	inch	mm	inch	mm	inch	mm	inch	mm	
TDP 20	1	25.4	0.609	15.5	2	50.8	1/4	6.35	9314350001053
TDP 20 1/2	1	25.4	0.609	15.5	2-3/8	60	1/2	12.7	9314350001060
TDP 35 1/2	1-1/4	31.8	0.76	19.3	2-3/4	70	1/2	12.7	9314350001077

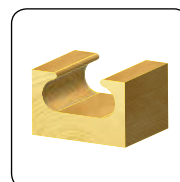
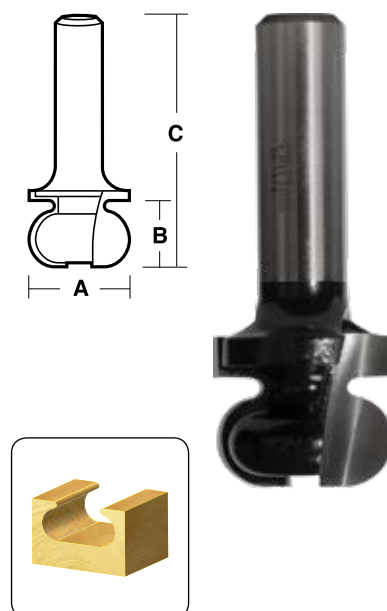

Drip Seal Groover

- Cuts 2.5mm wide & 8mm deep grooves
- For fitting drip, dust & smoke seals to window frames
- A countersunk screw securing the cutter allows for a flush cut

Part No.	A		B		C		Arbor No.	Shank		Barcode
	inch	mm	inch	mm	inch	mm		inch	mm	
TDSG 44 B	1-47/64	44	3/32	2.5	2-5/64	71	TA 25	1/4	6.35	9314350026278
TDSG 44 B 1/2	1-47/64	44	3/32	2.5	2-5/64	71	TA 26	1/2	12.7	9314350026285

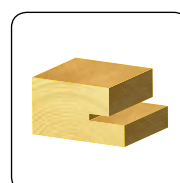
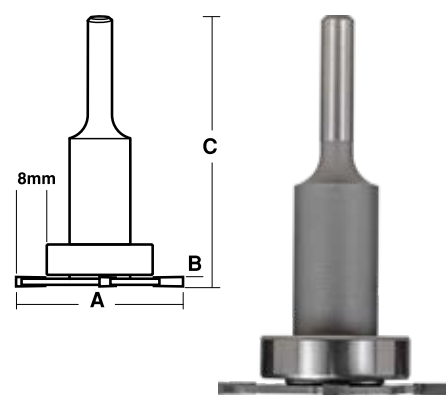

Replacement bearing TB17

Single Flute - Hook Slot Bit - Carbide Tipped

- For drilling/slotting a screw, nail or hook slot in the back of a picture frame, mirror, hanging shield etc

Product Group R571 **Discount Group** Z0904

Part No.	A1		A2		B1		B2		C		Shank		Barcode
	inch	mm	inch	mm	inch	mm	inch	mm	inch	mm	inch	mm	
THS12	0.355	9	3/16	4.8	1/8	3.2	3/8	9.5	1-5/8	41	1/4	6.35	9314350000896
THS16	1/2	12.7	5/16	8	1/8	3.2	1/2	12.7	1-3/4	44.4	1/4	6.35	9314350000902
THS16 1/2	1/2	12.7	5/16	8	1/8	3.2	1/2	12.7	2-5/8	67	1/2	12.7	9314350000919

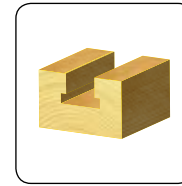
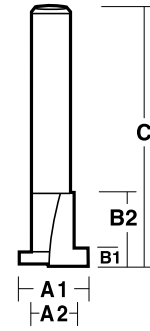

T-Slot Cutter - Carbide Tipped

- For horizontal T-slots
- Used for hanging brackets or creating wall display units, slatwall etc

Product Group R572 **Discount Group** Z0904

Part No.	A1		A2		B1		B2		C		Shank		Barcode
	inch	mm	inch	mm	inch	mm	inch	mm	inch	mm	inch	mm	
TSA 28 1/2	1-7/64	28	25/64	10	57/64	22.7	25/64	10	3-3/32	78.5	1/2	12.7	9314350009349
TSA 30 1/2	1-3/16	30	25/64	10	57/64	22.7	25/64	10	3-3/32	78.5	1/2	12.7	9314350012981
TSA 30.6 1/2	1-13/64	30.6	27/64	10.6	45/64	18	25/64	10	3-3/32	78.5	1/2	12.7	9314350019560

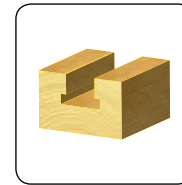
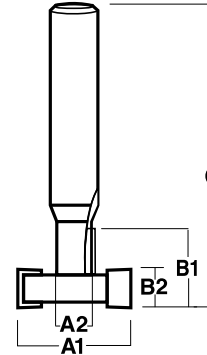

Single Flute - 22.5° Vee Groove Bit - Solid Carbide

- 22.5° included angle
- Suitable for engraving, grooving and edge forming
- 11.25° from vertical

Product Group R573 **Discount Group** Z0912

Part No.	A		B		C		Shank		Barcode
	inch	mm	inch	mm	inch	mm	inch	mm	
TV 2208	1/4	6.4	37/64	14.7	2-1/4	57.2	1/4	6.35	9314350015821
TV 2216 1/2	1/2	12.7	1-13/64	30.6	3	76.2	1/2	12.7	9314350015838

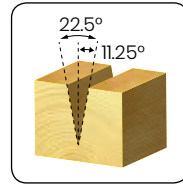
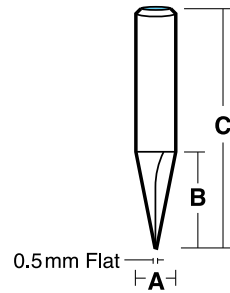

22.5°

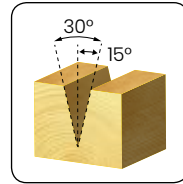

30°

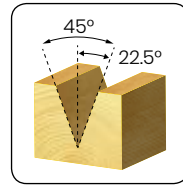

45°

Single Flute - 30° Vee Groove Bit - Solid Carbide

- 30° included angle
- Suitable for engraving, grooving and edge forming
- 15° from vertical

Product Group R574 **Discount Group** Z0912

Part No.	A		B		C		Shank		Barcode
	inch	mm	inch	mm	inch	mm	inch	mm	
TV 3008	1/4	6.4	-	10.9	2-1/4	57.2	1/4	6.35	9314350015845
TV 3016 1/2	1/2	12.7	-	22.8	3	76.2	1/2	12.7	9314350015852

Single Flute - 45° Vee Groove Bit - Solid Carbide

- 45° included angle
- Suitable for engraving, grooving and edge forming
- 22.5° included angle 15° from vertical

Product Group R575 **Discount Group** Z0912

Part No.	A		B		C		Shank		Barcode
	inch	mm	inch	mm	inch	mm	inch	mm	
TV 4508	1/4	6.35	-	7	2-1/4	57.15	1/4	6.35	9314350025547
TV 4516 1/2	1/2	12.7	37/64	14.7	3	76.2	1/2	12.7	9314350025330

2 Flute - 60° Vee Groove Bit - Carbide Tipped

- 60° included angle
- This bit is specifically designed for sign and lettering work

Product Group R576 **Discount Group** Z0904

Part No.	A		B		C		Shank		Barcode
	inch	mm	inch	mm	inch	mm	inch	mm	
T 6128	1	25.4	-	22.4	2-1/4	57.1	1/4	6.35	9314350004412
T 6128 1/2	1	25.4	-	22.4	2-3/4	70	1/2	12.7	9314350004429

Note: These bits are not guaranteed against tip breakage due to thin section of carbide at the point.

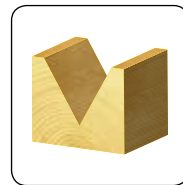
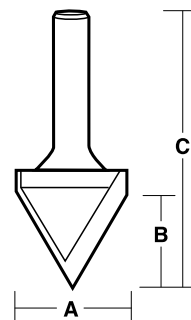

60°

2 Flute - 90° Vee Groove Bit

- 90° included angle
- A versatile bit for decorative vee grooves and chamfering
- Used for sign and lettering work
- -

Product Group	Discount Group
R577	Z0906

Part No.	A		B		C		Shank		Barcode
	inch	mm	inch	mm	inch	mm	inch	mm	
H112	17/32	13.5	3/8	9.5	1-3/8	35	1/4	6.35	9314350004344

Product Group	Discount Group
R578	Z0904

Part No.	A		B		C		Shank		Barcode
	inch	mm	inch	mm	inch	mm	inch	mm	
T112	45/64	18	0.365	9.2	1-3/4	44.4	1/4	6.35	9314350004368
T128	1-15/64	31.3	5/8	15.9	2	50.8	1/4	6.35	9314350004375
T128 1/2	1-15/64	31.3	5/8	15.9	2-1/2	63.5	1/2	12.7	9314350004382
T1230 1/2	1-9/16	39.7	25/32	20	3-3/8	86	1/2	12.7	9314350004399
T1236 1/2	1-49/64	45	-	22.5	3-13/64	81.5	1/2	12.7	9314350025806
T1240 1/2	2	50.8	1	25.4	3	76	1/2	12.7	9314350004405

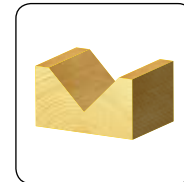
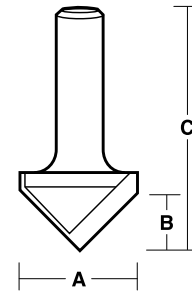

2 Flute - 90° Vee Groove Bit with Flat - Carbide Tipped

- 90° included angle
- For routing aluminium composite materials to be bent to 90°
- Routs ACP in hand held or CNC routers

Product Group	Discount Group
R579	Z0904

Part No.	A		A1		B		C		Shank		Barcode
	inch	mm	inch	mm	inch	mm	inch	mm	inch	mm	
T112 W/F	-	18	-	3	-	7.5	-	45	1/4	6.35	9314350025301
T128 W/F	-	31.3	-	3	-	14.7	-	52	1/4	6.35	9314350023772
T128 1/2 W/F	-	31.3	-	3	-	14.7	-	64	1/2	12.7	9314350025141

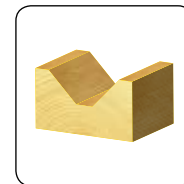
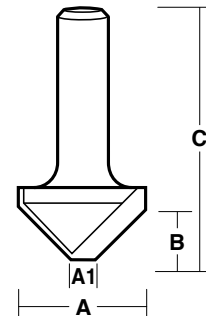

2 Flute - 120° Vee Groove Bit - Carbide Tipped

- 120° included angle

Product Group	Discount Group
R580	Z0904

Part No.	A		B		C		Shank		Barcode
	inch	mm	inch	mm	inch	mm	inch	mm	
TV1232	1	25.4	-	7.5	1-45/64	43.3	1/4	6.35	9314350015807
TV1232 1/2	1	25.4	-	7.5	2-13/64	55.9	1/2	12.7	9314350015814
TV1264 1/2	2	50.8	-	14.7	2-29/32	73.8	1/2	12.7	9314350015920

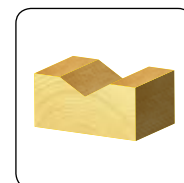
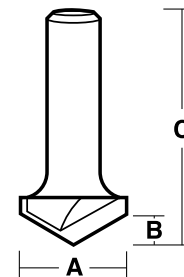

2 Flute - 150° Vee Groove Bit - Carbide Tipped

- 150° included angle

Product Group	Discount Group
R581	Z0904

Part No.	A		B		C		Shank		Barcode
	inch	mm	inch	mm	inch	mm	inch	mm	
TV 1532	1	25.4	-	3.4	1-19/32	40.4	1/4	6.35	9314350025622
TV 1532 1/2	1	25.4	-	3.4	2.1	53.4	1/2	12.7	9314350025639
TV 1564 1/2	2	50.8	-	6.8	2-19/32	65.8	1/2	12.7	9314350025646

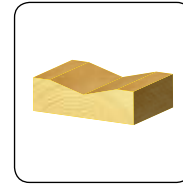
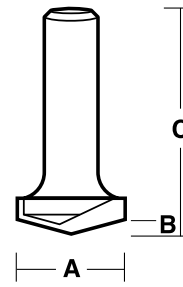

Single Flute - Provincial Design Veining Bit - Solid Carbide

- 90° included angle
- For recess design veining in fine cabinet surfaces
- Designed for template routing

Product Group	Discount Group
R582	Z0912

Part No.	A		B		C		Shank		Barcode
	inch	mm	inch	mm	inch	mm	inch	mm	
T 503 - 502	3/32	2.4	1/4	6.35	1-1/2	38.1	1/4	6.35	9314350001398
T 503 - 503	1/8	3.2	1/4	6.35	1-1/2	38.1	1/4	6.35	9314350001404
T 503 - 504	3/16	4.8	1/4	6.35	1-1/2	38.1	1/4	6.35	9314350001411
T 503 - 505	1/4	6.35	3/8	9.5	1-1/2	38.1	1/4	6.35	9314350001428

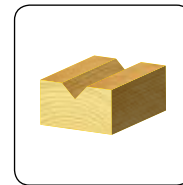
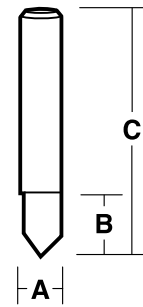

Single Flute - Veining Bit

- For grooving and scoring panel designs in wood surfaces

Product Group	Discount Group
R583	Z0906

Part No.	A		B		C		Shank		Barcode
	inch	mm	inch	mm	inch	mm	inch	mm	
HIGH SPEED STEEL									
H 304	1/8	3.2	5/16	7.9	1-5/8	41	1/4	6.35	9314350001459

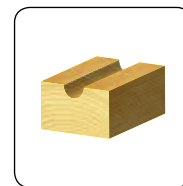
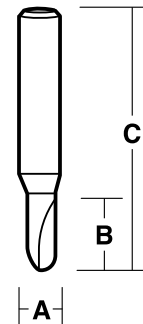

Product Group	Discount Group
R584	Z0912

Part No.	A		B		C		Shank		Barcode
	inch	mm	inch	mm	inch	mm	inch	mm	
SOLID CARBIDE									
T 302	1/16	1.6	3/16	4.8	1-1/2	38.1	1/4	6.35	9314350004436
T 303	3/32	2.4	3/16	4.8	1-1/2	38.1	1/4	6.35	9314350004443
T 304	1/8	3.2	5/16	7.9	1-1/2	38.1	1/4	6.35	9314350004450
T 305	5/32	4	5/16	7.9	1-1/2	38.1	1/4	6.35	9314350004467
T 306	3/16	4.8	7/16	11.1	1-1/2	38.1	1/4	6.35	9314350004474
T 307	7/32	5.5	7/16	11.1	1-1/2	38.1	1/4	6.35	9314350004481

ROUTER BITS



2 Flute - Core Box Bit

- For use in fluting flat surfaces such as mantles and facades
- Use for signage lettering

Product Group R585 **Discount Group** Z0906

Part No.	A		B		C		R Radius		Shank		Barcode
	inch	mm	inch	mm	inch	mm	inch	mm	inch	mm	
HIGH SPEED STEEL											
H 408	1/4	6.35	1/4	6.35	1-1/4	31.8	1/8	3.2	1/4	6.35	9314350004498
H 412	3/8	9.5	1/4	6.35	1-1/4	31.8	3/16	4.8	1/4	6.35	9314350004504
H 416	1/2	12.7	11/32	8.7	1-1/4	31.8	1/4	6.35	1/4	6.35	9314350004511
H 420	5/8	15.9	3/8	9.5	1-3/8	35	5/16	8	1/4	6.35	9314350004528
H 424	3/4	19	15/32	12	1-3/8	35	3/8	9.5	1/4	6.35	9314350004535

Product Group R586 **Discount Group** Z0912

Part No.	A		B		C		R Radius		Shank		Barcode
	inch	mm	inch	mm	inch	mm	inch	mm	inch	mm	
SOLID CARBIDE											
T 408	1/4	6.35	5/16	8	1-1/2	38.1	1/8	3.2	1/4	6.35	9314350004542

Product Group R587 **Discount Group** Z0904

Part No.	A		B		C		R Radius		Shank		Barcode
	inch	mm	inch	mm	inch	mm	inch	mm	inch	mm	
CARBIDE TIPPED											
T 410	5/16	7.9	1/4	6.35	1-1/4	31.8	5/32	4	1/4	6.35	9314350004559
T 412	3/8	9.5	1/4	6.35	1-1/4	31.8	3/16	4.8	1/4	6.35	9314350004566
T 416	1/2	12.7	31/64	12.2	1-1/2	38.1	1/4	6.35	1/4	6.35	9314350004573
T 416 1/2	1/2	12.7	31/64	12.2	2-1/4	57.1	1/4	6.35	1/2	12.7	9314350009264
T 420	5/8	15.9	3/8	9.5	1-3/4	44.4	5/16	8	1/4	6.35	9314350004580
T 420 1/2	5/8	15.9	3/8	9.5	2-1/4	57.1	5/16	8	1/2	12.7	9314350009271
T 424	3/4	19	1/2	12.7	1-7/8	47	3/8	9.5	1/4	6.35	9314350004597
T 424 1/2	3/4	19	1/2	12.7	2-1/4	57.1	3/8	9.5	1/2	12.7	9314350004603
T 432 1/2	1	25.4	5/8	15.9	2-1/2	63.5	1/2	12.7	1/2	12.7	9314350004610
T 440 1/2	1-1/4	31.8	3/4	19	2-1/2	63.5	5/8	15.9	1/2	12.7	9314350004627
T 448 1/2	1-1/2	38	7/8	22.2	2-5/8	67	3/4	19	1/2	12.7	9314350008434

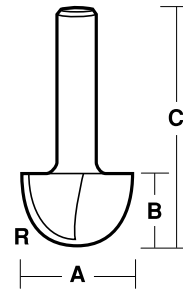

H 412

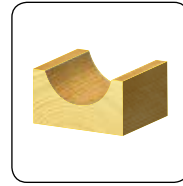

T 408



T 416

2 Flute - Round Nose Bit - Carbide Tipped

- For decorative coves and veins
- Suits some "copy" routers

Product Group R588 **Discount Group** Z0904

Part No.	A		B		C		R Radius		Shank		Barcode
	inch	mm	inch	mm	inch	mm	inch	mm	inch	mm	
TRN 416 1/2	1/2	12.7	1-1/4	31.75	3.0	76.7	1/4	6.35	1/2	12.7	9314350025844
TRN 420 1/2	5/8	15.9	1-1/4	31.75	3.0	76.7	5/16	8	1/2	12.7	9314350025851
TRN 424 1/2	3/4	19	1-1/2	38.1	3.27	83.1	3/8	9.5	1/2	12.7	9314350025868

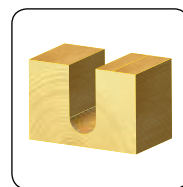
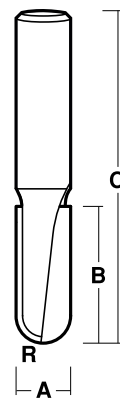

2 Flute - Ball End Bit - Carbide Tipped

- For cutting a channel for ropes, cables or pipes

Product Group **Discount Group**
R589 Z0904

Part No.	A		B		C		R Radius		Shank		Barcode
	inch	mm	inch	mm	inch	mm	inch	mm	inch	mm	
TBE 416 1/2	1/2	12.7	7/16	11	2-13/64	56	1/4	6.35	1/2	12.7	9314350025653
TBE 420 1/2	5/8	15.9	9/16	14.2	2-21/64	59.2	5/16	8	1/2	12.7	9314350025660
TBE 424 1/2	3/4	19	11/16	17.5	2.46	62.5	3/8	9.5	1/2	12.7	9314350025677

We recommend cutting a straight groove prior to using the ball end bit to ease the cutting pressure on the tool

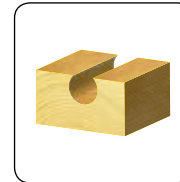
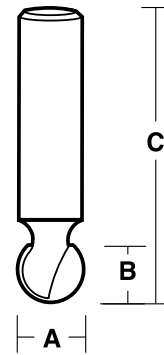

Half Core Box Bit

- Large radius for wide, shallow recess

Product Group **Discount Group**
R590 Z0904

Part No.	A		B		C		R Radius		Shank		Barcode
	inch	mm	inch	mm	inch	mm	inch	mm	inch	mm	
THC 45 1/2	2-1/2	63.5	43/64	17	2-45/64	68.7	-	45	1/2	12.7	9314350015128
THC 75 1/2	3	76.2	23/32	18.3	2-13/16	71.4	2-61/64	75	1/2	12.7	9314350015135

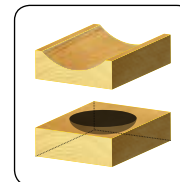
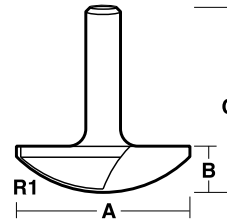

ROUTER BITS



2 Flute - Ogee Bit

- Use with template or guide for face forming
- Use with fence for edge forming

Product Group **Discount Group**
R591 Z0906

Part No.	A1 mm	A2 mm	B inch	C mm	R Radius inch	Shank mm	Barcode
HIGH SPEED STEEL							
H 7506	20	4.8	5/8	15.9	1-3/4	44.4	9314350004825
H 7509	20	4.8	7/8	22.2	1-7/8	47	9314350004832

Product Group **Discount Group**
R592 Z0904

Part No.	A1 mm	A2 mm	B inch	C mm	R Radius inch	Shank mm	Barcode
CARBIDE TIPPED							
T 7502	9.9	3.6	3/8	9.5	1-7/8	47	9314350004849
T 7502 1/2	9.9	3.6	3/8	9.5	2-1/2	63.5	9314350004856
T 7504	16.2	3.6	1/2	12.7	1-7/8	47	9314350004863
T 7504 1/2	16.2	3.6	1/2	12.7	2-1/2	63.5	9314350004870
T 7506	23.8	4.8	5/8	15.9	1-7/8	47	9314350004887
T 7506 1/2	23.8	4.8	5/8	15.9	2-1/2	63.5	9314350004894
T 7509	31.2	4.8	45/64	18	1-7/8	47	9314350004900
T 7509 1/2	31.2	4.8	45/64	18	2-1/2	63.5	9314350004917

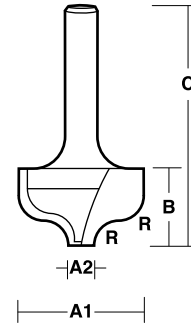

H 7506

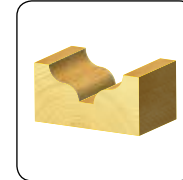

T 7506

2 Flute - Ogee Bit Fine Point - Carbide Tipped

- For Ogee grooves where a fine point is required
- Used extensively in router lathe work for forming barley twist patterns
- Use with template or guide for face forming

Product Group **Discount Group**
R593 Z0904

Part No.	A inch	B mm	C inch	R Radius mm	Shank mm	Barcode	
TF 7506	0.815	20.7	33/64	13	1-7/8	47	9314350004788
TF 7506 1/2	0.815	20.7	33/64	13	2-1/4	57.1	9314350004795
TF 7509	1.04	26.4	5/8	15.9	1-7/8	47	9314350004801
TF 7509 1/2	1.04	26.4	5/8	15.9	2-1/2	63.5	9314350004818

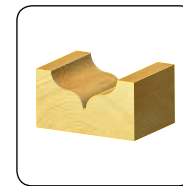
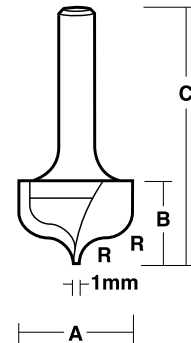

2 Flute - Ogee Bit Rounded Bottom - Carbide Tipped

- Used for decorative plunge cutting, grooving or edge forming
- Use with template or guide for face forming
- Use with fence for edge forming

Product Group **Discount Group**
R594 Z0904

Part No.	A inch	B mm	C inch	R Radius mm	Shank mm	Barcode	
TR 7506	0.937	23.7	0.580	14.7	1-7/8	47	9314350011854
TR 7506 1/2	0.937	23.7	0.58	14.7	2-1/2	63.5	9314350011861
TR 7509	1-1/4	32	0.7	17.7	1-7/8	47	9314350011878
TR 7509 1/2	1-1/4	32	0.7	17.7	2-1/2	63.5	9314350011885

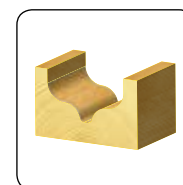
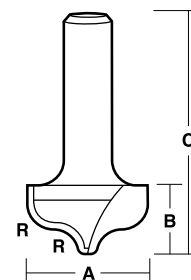

2 Flute - Ogee Bit Rounded Bottom - Carbide Tipped

- Used for decorative plunge cutting, grooving or edge forming
- Use with template or guide for face forming
- Use with fence for edge forming

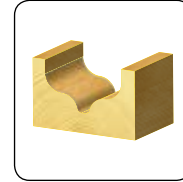
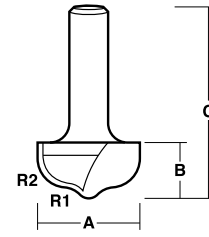

Product Group	Discount Group
R595	Z0904

Part No.	A		B		C		R1 Radius		R2 Radius		Shank		Barcode
	inch	mm	inch	mm	inch	mm	inch	mm	inch	mm	inch	mm	
TRS 7506 1/2	1	25.4	19/32	15.1	2-25/64	60.7	5/16	7.9	3/16	4.8	1/2	12.7	9314350015081
TRS 7509 1/2	-	33.5	23/32	18.3	2-25/64	61	5/16	7.9	3/8	9.5	1/2	12.7	9314350015098

2 Flute - Ogee Bit Wide Flat Bottom - Carbide Tipped

- Designed for grooving panel doors and decorative edge moulds
- Use with template or guide for face forming
- Use with fence for edge forming

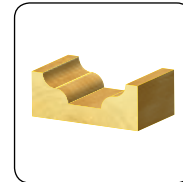
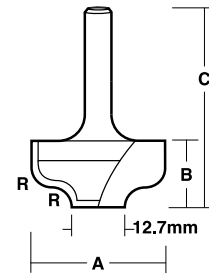

Product Group	Discount Group
R596	Z0904

Part No.	A		B		C		R Radius		Shank		Barcode
	inch	mm	inch	mm	inch	mm	inch	mm	inch	mm	
TW 7506	1-1/4	31.8	5/8	15.9	1-7/8	47	3/16	4.8	1/4	6.35	9314350004924
TW 7506 1/2	1-1/4	31.8	5/8	15.9	2-1/2	63.5	3/16	4.8	1/2	12.7	9314350004931
TW 7509	1-1/2	38.1	3/4	19	2	50.8	1/4	6.35	1/4	6.35	9314350004948
TW 7509 1/2	1-1/2	38.1	3/4	19	2-1/2	63.5	1/4	6.35	1/2	12.7	9314350004955

2 Flute - Provincial Bit with Bearing - Carbide Tipped

- Used for decorative edge and face moulds
- Use with template or guide for face forming
- Use with fence for edge forming

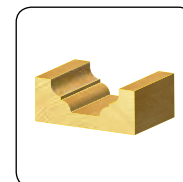
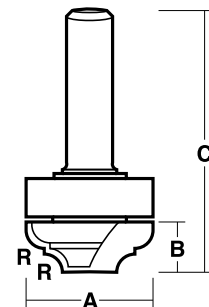

Product Group	Discount Group
R597	Z0904

Part No.	A		B		C		R Radius		Shank		Barcode
	inch	mm	inch	mm	inch	mm	inch	mm	inch	mm	
TCRR 3 B	-	22	25/64	10	2	50.8	1/8	3.2	1/4	6.35	9314350016507
TCRR 5 B 1/2	1-3/8	35	35/64	14	2-45/64	68.7	-	5	1/2	12.7	9314350016514

Replacement bearings
 - 1/4" Shank = TB 12
 - 1/2" Shank = TB 21

2 Flute - Classical Bit - Carbide Tipped

- Used for panel doors and decorative edge moulds
- Use with template or guide for face forming
- Use with fence for edge forming

Product Group R598 **Discount Group** Z0904

Part No.	A		B		C		R Radius		Shank		Barcode
	inch	mm	inch	mm	inch	mm	inch	mm	inch	mm	
TC 6	1/2	12.7	1/2	12.7	1-3/4	44.4	3/32	2.4	1/4	6.35	9314350004986
TC 6 1/2	1/2	12.7	1/2	12.7	2-1/2	63.5	3/32	2.4	1/2	12.7	9314350004993
TC 10	0.76	19.2	9/16	14.3	1-3/4	44.4	5/32	4	1/4	6.35	9314350005006
TC 10 1/2	0.76	19.2	9/16	14.3	2-5/16	58.6	5/32	4	1/2	12.7	9314350005013
TC 12 1/2	57/64	22.6	5/8	15.9	2-1/2	63.5	3/16	4.8	1/2	12.7	9314350005020
TC 16 1/2	1-5/32	29.2	3/4	19	2-1/2	63.5	1/4	6.35	1/2	12.7	9314350005037

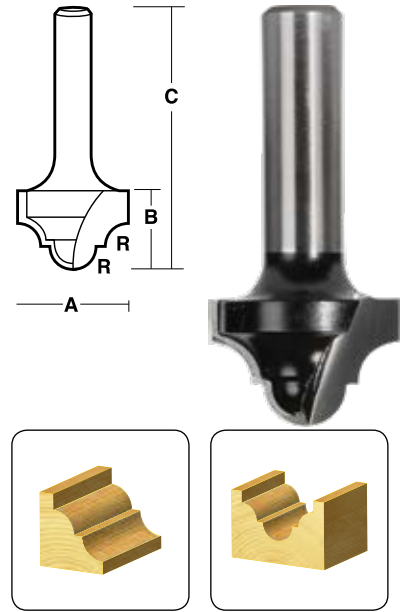

2 Flute - Traditional Classical Bit - Carbide Tipped

- Used for panel doors and decorative edge moulds
- Use with template or guide for face forming
- Use with fence for edge forming

Product Group R599 **Discount Group** Z0904

Part No.	A		B1		B2		Radius		Shank		Barcode
	inch	mm	inch	mm	inch	mm	inch	mm	inch	mm	
TTC 8	11/16	17.4	0.07	1.8	1/2	12.7	1/8	3.2	1/4	6.35	9314350005044
TTC 8 1/2	11/16	17.4	0.07	1.8	1/2	12.7	1/8	3.2	1/2	12.7	9314350005051
TTC 12	0.925	23.5	0.07	1.8	1/2	12.7	3/16	4.8	1/4	6.35	9314350005068
TTC 12 1/2	0.925	23.5	0.07	1.8	1/2	12.7	3/16	4.8	1/2	12.7	9314350005075
TTC 16 1/2	1.16	29.5	1/8	3.2	5/8	16	1/4	6.35	1/2	12.7	9314350005082

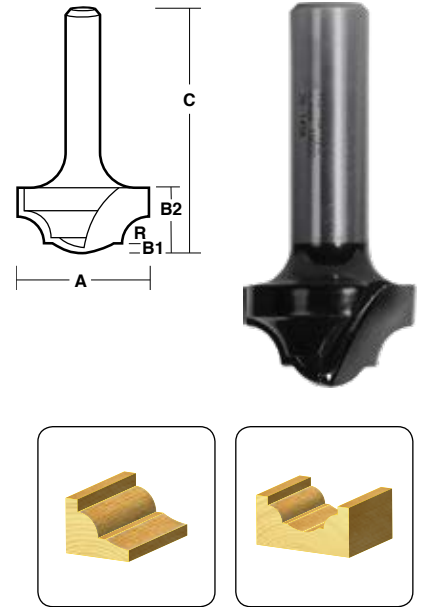

2 Flute - Traditional Classical Bit with Bearing - Carbide Tipped

- Used for panel doors and decorative edge moulds
- Use with template or guide for face forming
- Use with fence for edge forming

Product Group R600 **Discount Group** Z0904

Part No.	A		B1		B2		C		R1	R2	Shank		Barcode
	inch	mm	inch	mm	inch	mm	inch	mm	mm	mm	inch	mm	
TTCR 4 B	-	22	-	12.7	-	4.8	-	54	5.5	4.0	1/4	6.35	9314350016576
TTCR 6 B 1/2	-	35	-	14.3	-	4.8	-	73	10.3	6.0	1/2	12.7	9314350016583

Replacement bearing
 1/4" Shank = TB 12
 1/2" Shank = TB 21

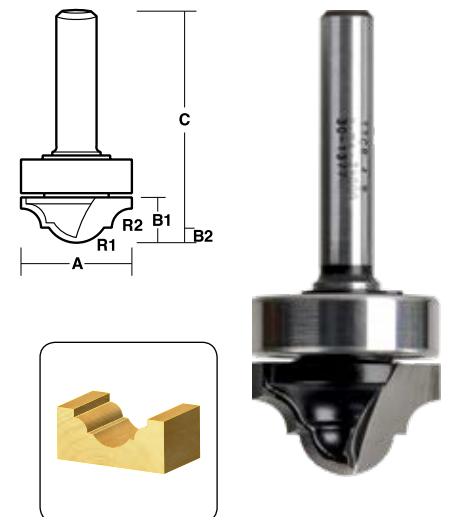

2 Flute - Beading Bit - Carbide Tipped

- For grooving panel designs in wood surfaces such as cupboard doors
- Use with template or guide for face forming
- Use with fence for edge forming

Product Group R601 **Discount Group** Z0904

Part No.	A		B		C		R Radius		Shank		Barcode
	inch	mm	inch	mm	inch	mm	inch	mm	inch	mm	
TBB 4	3/8	9.5	3/8	9.5	1-3/4	44.4	1/8	3.2	1/4	6.35	9314350004672
TBB 4 1/2	3/8	9.5	3/8	9.5	2-1/4	57.1	1/8	3.2	1/2	12.7	9314350004689
TBB 8	5/8	15.9	1/2	12.7	1-3/4	44.4	1/4	6.35	1/4	6.35	9314350004696
TBB 8 1/2	5/8	15.9	1/2	12.7	2-1/4	57.1	1/4	6.35	1/2	12.7	9314350004702

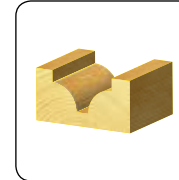
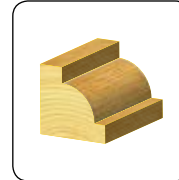
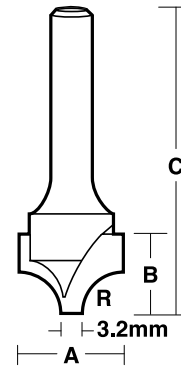

2 Flute - Beading Bit Fine Point - Carbide Tipped

- For beading the surface of material to a fine point
- Use with template or guide for face forming
- Use with fence for edge forming

Product Group R602 **Discount Group** Z0904

Part No.	A		B		C		R Radius		Shank		Barcode
	inch	mm	inch	mm	inch	mm	inch	mm	inch	mm	
TBF 4	0.29	7.4	3/8	9.5	1-3/4	44.4	1/8	3.2	1/4	6.35	9314350004634
TBF 4 1/2	0.29	7.4	3/8	9.5	2-5/8	67	1/8	3.2	1/2	12.7	9314350004641
TBF 8	-	13.7	1/2	12.7	1-3/4	44.4	1/4	6.35	1/4	6.35	9314350004658
TBF 8 1/2	-	13.7	1/2	12.7	2-5/8	67	1/4	6.35	1/2	12.7	9314350004665

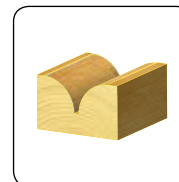
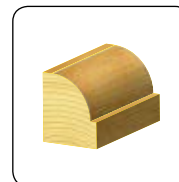
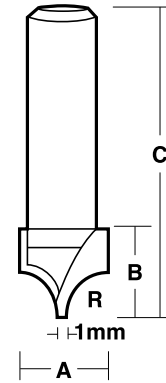

2 Flute - Beading Bit Wide Flat Bottom - Carbide Tipped

- Specially designed for grooving panel doors
- This bit produces a beading groove with a wide bottom
- Use with template guide for face forming

Product Group R603 **Discount Group** Z0904

Part No.	A		B		C		R Radius		Shank		Barcode
	inch	mm	inch	mm	inch	mm	inch	mm	inch	mm	
TBW 4	3/4	19	7/16	11.1	1-3/4	44.4	1/8	3.2	1/4	6.35	9314350004719
TBW 4 1/2	3/4	19	7/16	11.1	2-1/4	57.1	1/8	3.2	1/2	12.7	9314350004726
TBW 8	1	25.4	3/4	19	2-3/8	50.8	1/4	6.35	1/4	6.35	9314350004733
TBW 8 1/2	1	25.4	3/4	19	2-3/8	50.8	1/4	6.35	1/2	12.7	9314350004740

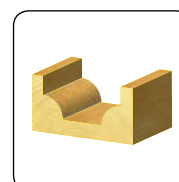
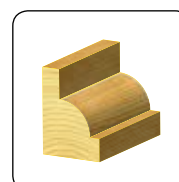
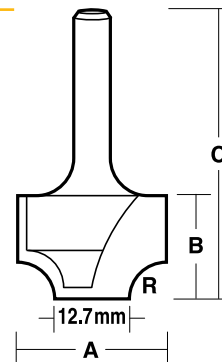

2 Flute - Double Beading Bit Wide Flat Bottom - Carbide Tipped

- Specially designed for grooving panel doors
- Also produces a decorative edge beading
- Use with template or guide for face forming

Product Group R604 **Discount Group** Z0904

Part No.	A		B		C		R Radius		Shank		Barcode
	inch	mm	inch	mm	inch	mm	inch	mm	inch	mm	
TBD 4	1	25.4	7/16	11.1	1-3/4	44.4	1/8	3.2	1/4	6.35	9314350004757
TBD 4 1/2	1	25.4	7/16	11.1	2-1/4	57.1	1/8	3.2	1/2	12.7	9314350004764
TBD 8 1/2	1-1/2	38.1	3/4	19	2-1/2	63.5	1/4	6.35	1/2	12.7	9314350004771

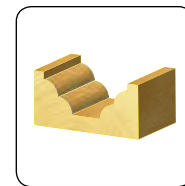
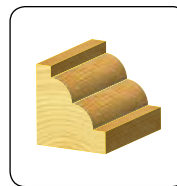
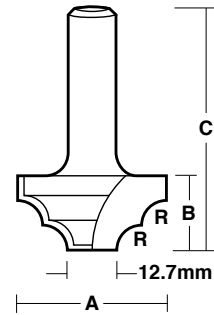

2 Flute - Extended Rounding Over Bit - Carbide Tipped

- For rounding over edges in areas where a ball bearing is not required
- Makes decorative edges, or can be used to plunge through the material
- Can edge form and part off material in one cut

Product Group R605 **Discount Group** Z0904

Part No.	A1		A2		B		C		Radius		Shank		Barcode
	inch	mm	inch	mm	inch	mm	inch	mm	inch	mm	inch	mm	
NO BEARING													
TX 506	-	20	-	10	-	16	-	53	-	5	1/4	6.35	9314350008298
TX 508	-	25	-	13	-	19	-	59	-	6	1/4	6.35	9314350008304
TX 508 1/2	-	25	-	13	-	19	-	72	-	6	1/2	12.7	9314350008311
TX 512 1/2	-	33	-	13	-	25	-	79	-	10	1/2	12.7	9314350008328
TX 516 1/2	-	39	-	13	-	25	-	84	-	13	1/2	12.7	9314350008335
TX 520 1/2	-	45	-	13	-	28.6	-	82	-	16	1/2	12.7	9314350008342
TX 524 1/2	-	51	-	13	-	31.8	-	90.8	-	19	1/2	12.7	9314350008359

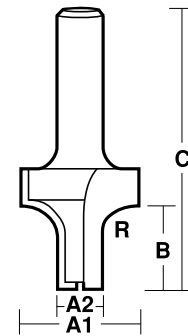

TX 506

Product Group R606 **Discount Group** Z0904

Part No.	A1		A2		B		C		Radius		Shank		Barcode
	inch	mm	inch	mm	inch	mm	inch	mm	inch	mm	inch	mm	
WITH BEARING													
TX 508 B 1/2	-	24.7	-	12.7	-	19	-	71	-	6	1/2	12.7	9314350016903
TX 512 B 1/2	-	32.7	-	12.7	-	25	-	74	-	10	1/2	12.7	9314350016910
TX 516 B 1/2	-	38.7	-	12.7	-	25	-	80	-	13	1/2	12.7	9314350016927

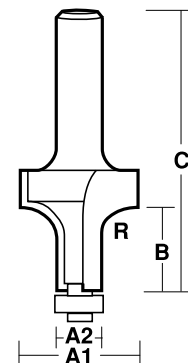

TX 508 B 1/2

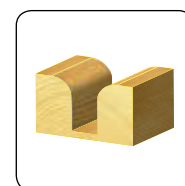
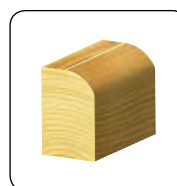

Replacement bearing TB11

2 Flute - Extended Double Beading Bit - Carbide Tipped

- Can edge form and part off material in one cut

Product Group **Discount Group**
R607 Z0904

Part No.	A		B		C		R1 Radius		R2 Radius		Shank		Barcode
	inch	mm	inch	mm	inch	mm	inch	mm	inch	mm	inch	mm	
TBX 604 1/2	1	25.4	-	32	2-29/32	73.8	1/8	3.2	1/8	3.2	1/2	12.7	9314350016590
TBX 606 1/2	1-1/8	28.6	-	32	3	76.2	3/16	4.8	1/8	3.2	1/2	12.7	9314350016606

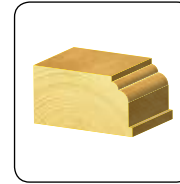
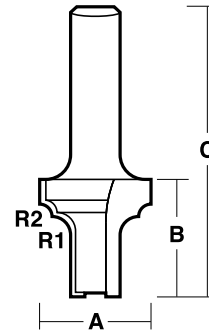

2 Flute - Extended Provincial Bit - Carbide Tipped

- Can edge form and part off material in one cut
- Traditional moulding
- Can use separate parts of the profile to make this an effective combination bit

Product Group **Discount Group**
R608 Z0904

Part No.	A		B		C		R1 Radius		R2 Radius		Shank		Barcode
	inch	mm	inch	mm	inch	mm	inch	mm	inch	mm	inch	mm	
TCRX 8 1/2	1	25.4	1-15/64	31.3	3	76.2	1/8	3.2	1/8	3.2	1/2	12.7	9314350016835
TCRX 12 1/2	1-1/8	28.6	1-19/64	32.9	3-7/64	79	3/16	4.8	1/8	3.2	1/2	12.7	9314350016842

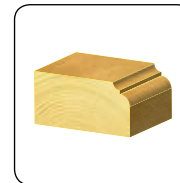
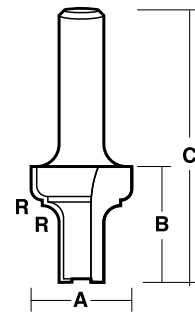

2 Flute - Dish Cut Bit - Carbide Tipped

- These bits are used for routing trays, bowls, plates and boxes
- They have a wide surface cut, to quickly remove excess material

Product Group R609 **Discount Group** Z0904

Part No.	A		B		C		R Radius		Shank		Barcode
	inch	mm	inch	mm	inch	mm	inch	mm	inch	mm	
TD 706 1/2	-	19	-	19	-	64	-	4.75	1/2	12.7	9314350008441
TD 716 1/2	-	32	-	32	-	77	-	6.5	1/2	12.7	9314350008458

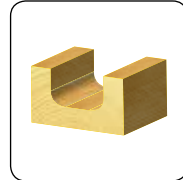
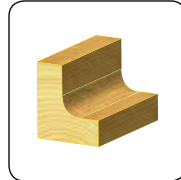
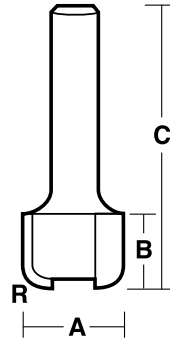

2 Flute - Dish Cut Bit with Bearing - Carbide Tipped

- These bits are used for routing trays, bowls, plates and boxes
- They have a wide surface cut, to quickly remove excess material

Product Group R610 **Discount Group** Z0904

Part No.	A		B		C		R Radius		Shank		Barcode
	inch	mm	inch	mm	inch	mm	inch	mm	inch	mm	
TD 706 B 1/2	-	19	-	19	-	76.8	-	4.75	1/2	12.7	9314350020122
TD 712 B 1/2	-	28.6	-	32	-	89.9	-	6	1/2	12.7	9314350020139

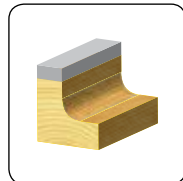
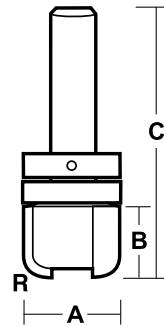

Replacement bearing TB4
Retaining ring TZR 3

2 Flute - Palace Pattern Bit with Ball Bearing Guide - Carbide Tipped

- An attractive edge mould for table and bench tops

<i>Product Group</i>		<i>Discount Group</i>											
R611		Z0904											
Part No.	A		B1		B2		C		Shank		Barcode		
	inch	mm	inch	mm	inch	mm	inch	mm	inch	mm			
TEB 09 B 1/2	1-1/4	31.8	1	25.4	9/32	7.1	3-1/8	79	1/2	12.7	9314350006911		
TEB 10 B 1/2	1-1/4	31.8	1	25.4	3/8	9.5	3-1/8	79	1/2	12.7	9314350006928		
TEB 11 B 1/2	1-5/16	33	1-9/32	32.5	0.590	15	3/8	86	1/2	12.7	9314350006935		
TEB 12 B 1/2	1-9/32	32.5	1-9/32	32.5	3/4	19	3-1/4	82	1/2	12.7	9314350006942		

Replacement bearing TB11

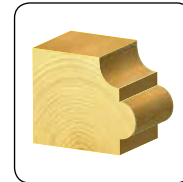
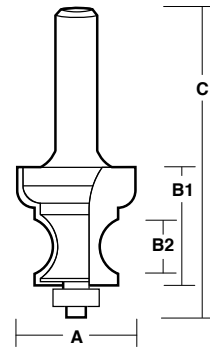

2 Flute - Rounding Over Bit with Pilot

- Ideal for drop leaf table joints and rounded edges
- Removes sharp corners

<i>Product Group</i>		<i>Discount Group</i>											
R932		Z0906											
Part No.	A		B		C		E		R Radius		Shank		Barcode
	inch	mm	inch	mm	inch	mm	inch	mm	inch	mm	inch	mm	
HIGH SPEED STEEL													
H 510	3/4	19	1/2	12.7	1-7/8	47	3/16	4.8	5/16	7.9	1/4	6.35	9314350006010
H 512	1	25.4	5/8	15.9	2	50.8	3/16	4.8	3/8	9.5	1/4	6.35	9314350006027
H 516	1-1/4	31.8	13/16	20.6	2	50.8	3/16	4.8	1/2	12.7	1/4	6.35	9314350006034

<i>Product Group</i>		<i>Discount Group</i>											
R612		Z0904											
Part No.	A		B		C		E		R Radius		Shank		Barcode
	inch	mm	inch	mm	inch	mm	inch	mm	inch	mm	inch	mm	
CARBIDE TIPPED													
T 506	9/16	14.2	1/2	12.7	1-3/4	44.4	3/16	4.8	3/16	4.8	1/4	6.35	9314350006041
T 508	11/16	17.5	9/16	14.3	1-7/8	47	3/16	4.8	1/4	6.35	1/4	6.35	9314350006058
T 510	13/16	20.6	9/16	14.3	1-7/8	47	3/16	4.8	5/16	7.9	1/4	6.35	9314350006065
T 512	15/16	23.8	5/8	15.9	2	50.8	3/16	4.8	3/8	9.5	1/4	6.35	9314350006072
T 516	1-3/16	30.1	13/16	20.6	2-1/4	57.1	3/16	4.8	1/2	12.7	1/4	6.35	9314350006089

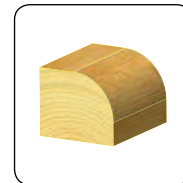
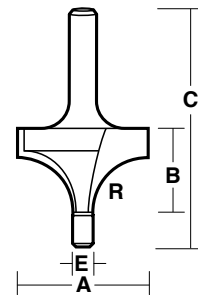

H 512



T 508



2 Flute - Rounding Over Bit with Ball Bearing Guide - Carbide Tipped

- Gives extra smooth chatter free cuts due to precise tool geometry
- Can be converted to a beading bit by using bearing TB 9

Product Group R613 Discount Group Z0904

Part No.	A		B		C		R Radius		Shank		Barcode
	inch	mm	inch	mm	inch	mm	inch	mm	inch	mm	
T 502 B	5/8	15.9	5/16	7.9	1-7/8	47	1/16	1.6	1/4	6.35	9314350006096
T 502 MB	21/32	16.7	11/32	8.7	17/8	47	5/64	2	1/4	6.35	9314350014671
T 504 B	3/4	19	1/2	12.7	2	50.8	1/8	3.2	1/4	6.35	9314350006102
T 504 MB	13/16	20.6	7/16	11.1	2	50.8	-	4	1/4	6.35	9314350010253
T 506 B	7/8	22.2	15/32	12	2	50.8	3/16	4.8	1/4	6.35	9314350006119
T 506 B 1/2	7/8	22.2	15/32	12	2-1/2	63.5	3/16	4.8	1/2	12.7	9314350010710
T 505 MB	7/8	22.5	15/32	12	2	50.8	-	5	1/4	6.35	9314350010260
T 506 MB	31/32	24.7	33/64	13	2-3/16	55.5	15/64	6	1/4	6.35	9314350025745
T 508 B	1	25.4	1/2	12.7	2	50.8	1/4	6.35	1/4	6.35	9314350006126
T 508 B 1/2	1	25.4	1/2	12.7	2-1/2	63.5	1/4	6.35	1/2	12.7	9314350006133
T 510 B	1-1/8	28.6	1/2	12.7	2	50.8	5/16	7.9	1/4	6.35	9314350006140
T 510 B 1/2	1-1/8	28.6	1/2	12.7	2-5/8	67	5/16	7.9	1/2	12.7	9314350006157
T 512 B	1-1/4	31.8	5/8	15.9	2-1/4	57.1	3/8	9.5	1/4	6.35	9314350006164
T 512 B 1/2	1-1/4	31.8	5/8	15.9	2-5/8	67	3/8	9.5	1/2	12.7	9314350006171
T 510 MB 1/2	1-9/32	32.7	21/32	16.5	2-53/64	72	25/64	10	1/2	12.7	9314350025752
T 512 MB 1/2	1-7/16	36.7	45/64	18	2-57/64	73.5	15/32	12	1/2	12.7	9314350025769
T 516 B	1-1/2	38.1	3/4	19	2-1/4	57.1	1/2	12.7	1/4	6.35	9314350006188
T 516 B 1/2	1-1/2	38.1	3/4	19	2-3/4	70	1/2	12.7	1/2	12.7	9314350006195
T 520 B 1/2	1-3/4	44.5	7/8	22.2	3-1/4	82	5/8	15.9	1/2	12.7	9314350006201
T 524 B 1/2	2	50.8	1	25.4	3-1/4	82	3/4	19	1/2	12.7	9314350006218
T 528 B 1/2	2-1/4	57.1	1-5/64	27.4	3-1/2	89	7/8	22.2	1/2	12.7	9314350006225
T 532 B 1/2	2-1/2	63.5	1-1/4	31.8	3-5/8	92	1	25.4	1/2	12.7	9314350006232
T 540 B 1/2	3	76.2	1-15/32	37.3	3-3/4	95	1-1/4	31.8	1/2	12.7	9314350006249

Replacement bearing TB11

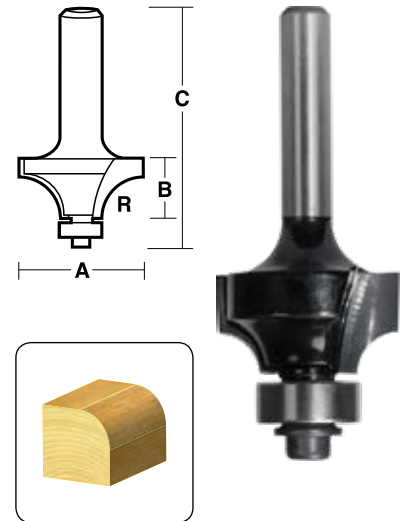

2 Flute - Rounding Over Fillet Bit with Ball Bearing Guide - Carbide Tipped

- These bits are very popular for table and bench tops
- Profiles are variable by raising and lowering the bit
- Produces partial or elliptical radius

Product Group R614 Discount Group Z0904

Part No.	A		B		C		Bearing No.	Shank		Barcode
	inch	mm	inch	mm	inch	mm		inch	mm	
TEB 01 B 1/2	2-1/4	57.1	15/16	23.8	3-1/4	82	TB11	1/2	12.7	9314350007369
TEB 02 B 1/2	2-1/4	57.1	15/16	23.8	3-1/4	82	TB9	1/2	12.7	9314350007376
TEB 03 B 1/2	2.8	71.1	15/16	23.8	3-1/4	82	TB11	1/2	12.7	9314350007383
TEB 04 B 1/2	2.8	71.1	15/16	23.8	3-1/4	82	TB9	1/2	12.7	9314350007390

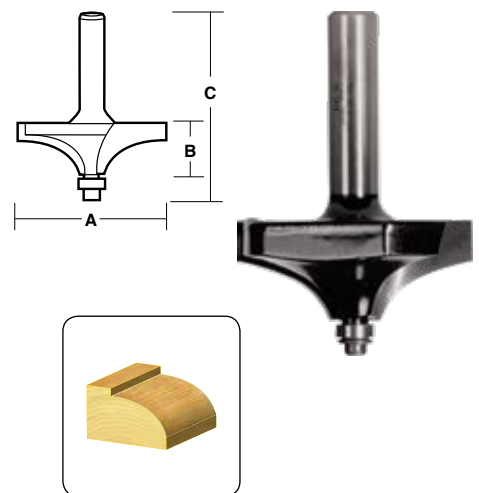

2 Flute - Beading Bit with Pilot

- High speed steel
- A decorative edge with pilot for early American furniture making

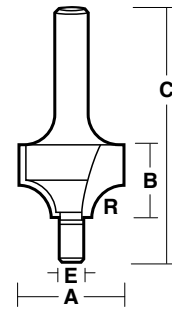

H 604

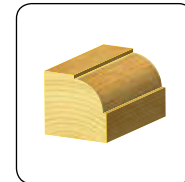

Product Group	Discount Group
R615	Z0906

Part No.	A		B		C		E		R Radius		Shank		Barcode
	inch	mm	inch	mm	inch	mm	inch	mm	inch	mm	inch	mm	
H 604	3/4	19	3/8	9.5	1-7/8	47	3/16	4.8	1/8	3.2	1/4	6.35	9314350006256
H 608	3/4	19	1/2	12.7	1-7/8	47	3/16	4.8	1/4	6.35	1/4	6.35	9314350006263
H 612	1	25	5/8	15.9	2	50.8	3/16	4.8	3/8	9.5	1/4	6.35	9314350006270

Product Group	Discount Group
R616	Z0904

Part No.	A		B		C		E		R Radius		Shank		Barcode
	inch	mm	inch	mm	inch	mm	inch	mm	inch	mm	inch	mm	
T 604	9/16	14.3	1/2	12.7	1-5/8	41	3/16	4.8	1/8	3.2	1/4	6.35	9314350001664
T 608	13/16	20.6	9/16	14.2	1-5/8	41	3/16	4.8	1/4	6.35	1/4	6.35	9314350001671
T 612	1-1/16	27	5/8	15.9	2	50.8	3/16	4.8	3/8	9.5	1/4	6.35	9314350001688

2 Flute - Beading Bit with Ball Bearing Guide - Carbide Tipped

- Smaller TB9 bearing leaves a 1/16" edge bead
- Can be converted to rounding over bit by using bearing TB11
- Bearing exposes bottom corner of cutter allowing it to cut the bottom bead
- Use machines height adjustment to drop top corner of cutter into the workpiece to create top bead

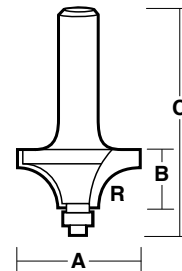

T 604

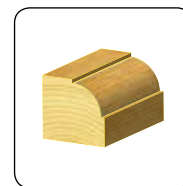

Product Group	Discount Group
R617	Z0904

Part No.	A		B		C		R Radius		Shank		Barcode
	inch	mm	inch	mm	inch	mm	inch	mm	inch	mm	
T 602 B	5/8	15.9	5/16	7.9	1-7/8	47	1/16	1.6	1/4	6.35	9314350006287
T 602 MB	21/32	16.7	11/32	8.7	1-7/8	47	5/64	2	1/4	6.35	9314350016859
T 604 B	3/4	19	1/2	12.7	2	50.8	1/8	3.2	1/4	6.35	9314350006294
T 604 MB	13/16	20.6	7/16	11.1	2	50.8	-	4	1/4	6.35	9314350012318
T 606 B	7/8	22.2	15/32	12	2	50.8	3/16	4.8	1/4	6.35	9314350006300
T 606 B 1/2	7/8	22.2	15/32	12	2-1/2	63.5	3/16	4.8	1/2	12.7	9314350010826
T 605 MB	7/8	22.2	15/32	12	2	50.8	-	5	1/4	6.35	9314350012325
T 606 MB	31/32	24.7	33/64	13	2-3/32	53.2	15/64	6	1/2	12.7	9314350025776
T 608 B	1	25.4	1/2	12.7	2	50.8	1/4	6.35	1/4	6.35	9314350006317
T 608 B 1/2	1	25.4	1/2	12.7	2-1/2	63.5	1/4	6.35	1/2	12.7	9314350006324
T 610 B	1-1/8	28.6	1/2	12.7	2	50.8	5/16	7.9	1/4	6.35	9314350006331
T 610 B 1/2	1-1/8	28.6	1/2	12.7	2-5/8	67	5/16	7.9	1/2	12.7	9314350006348
T 612 B	1-1/4	31.8	5/8	15.9	2-1/4	57.1	3/8	9.5	1/4	6.35	9314350006355
T 612 B 1/2	1-1/4	31.8	5/8	15.9	2-5/8	67	3/8	9.5	1/2	12.7	9314350006362
T 610 MB 1/2	1-9/32	32.7	21/32	16.5	2-3/4	69.7	25/64	10	1/2	12.7	9314350025783
T 612 MB 1/2	1-7/16	36.7	45/64	18	2-5/64	71.2	15/32	12	1/2	12.7	9314350025790
T 616 B	1-1/2	38.1	3/4	19	2-1/4	57.1	1/2	12.7	1/4	6.35	9314350006379
T 616 B 1/2	1-1/2	38.1	3/4	19	2-3/4	70	1/2	12.7	1/2	12.7	9314350006386
T 620 B 1/2	1-3/4	44.5	7/8	22.2	3-1/4	82	5/8	15.9	1/2	12.7	9314350006393
T 624 B 1/2	2	50.8	1	25.4	3-1/4	82	3/4	19	1/2	12.7	9314350006409
T 628 B 1/2	2-1/4	57.1	1-5/64	27.4	3-1/2	89	7/8	22.2	1/2	12.7	9314350006416
T 632 B 1/2	2-1/2	63.5	1-1/4	31.8	3-5/8	92	1	25.4	1/2	12.7	9314350006423
T 640 B 1/2	3	76.2	1-15/32	37.3	3-3/4	95	1-1/4	31.8	1/2	12.7	9314350006430

Replacement bearing TB9



2 Flute - Double Beading Bit with Ball Bearing Guide - Carbide Tipped

- A decorative edge bead
- Use as a combination bit by utilizing only part of the profile

Product Group R618 **Discount Group** Z0904

Part No.	A		B		C		R1 Radius		R2 Radius		Shank		Barcode
	inch	mm	inch	mm	inch	mm	inch	mm	inch	mm	inch	mm	
TB 606 B	1-3/8	35	11/16	17.4	2-1/4	57.1	3/16	4.8	1/4	6.35	1/4	6.35	9314350001763
TB 606 B 1/2	1-3/8	35	11/16	17.4	2-3/4	70	3/16	4.8	1/4	6.35	1/2	12.7	9314350001770
TB 608 B 1/2	1-5/8	41	7/8	22.2	3-1/8	79	1/4	6.35	5/16	7.9	1/2	12.7	9314350001787

Replacement bearing TB9

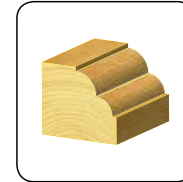
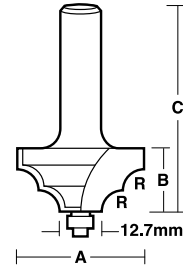

2 Flute - Double Beading Bit with Ball Bearing Guide - Carbide Tipped

- A decorative edge bead
- Effective combination bit

Product Group R619 **Discount Group** Z0904

Part No.	A		B		C		R1 Radius		R2 Radius		Shank		Barcode
	inch	mm	inch	mm	inch	mm	inch	mm	inch	mm	inch	mm	
TBR 608 B	1-1/4	31.8	17/32	13.3	2	50.8	1/4	6.4	1/8	3.2	1/4	6.35	9314350016446
TBR 608 B 1/2	1-1/4	31.8	17/32	13.3	2-1/2	63.5	1/4	6.4	1/8	3.2	1/2	12.7	9314350016453
TBR 616 B 1/2	2	50.8	29/32	22.9	3-1/8	79.4	1/2	12.7	1/4	6.35	1/2	12.7	9314350016460

Replacement bearing TB9

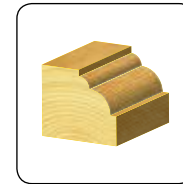
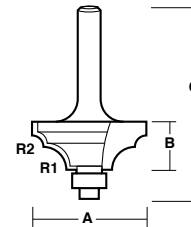

2 Flute - Triple Beading Bit with Ball Bearing Guide - Carbide Tipped

- A decorative edge bead
- Effective combination bit

Product Group R620 **Discount Group** Z0904

Part No.	A		B		C		R1 Radius		R2 Radius		Shank		Barcode
	inch	mm	inch	mm	inch	mm	inch	mm	inch	mm	inch	mm	
TT 606 B 1/2	1-3/4	44.4	7/8	22.2	3-1/4	82	3/16	4.8	1/4	6.35	1/2	12.7	9314350001794
TT 608 B 1/2	2-1/8	54	1-1/16	27	3-1/4	82	1/4	6.35	5/16	7.9	1/2	12.7	9314350001800

Replacement bearing TB9

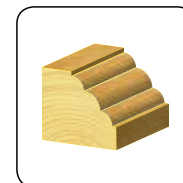
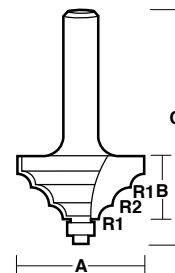

2 Flute - Beading Ogee Bit with Ball Bearing Guide - Carbide Tipped

- Produces decorative edge moulding

Product Group R621 **Discount Group** Z0904

Part No.	A		B		C		R1 Radius		R2 Radius		Shank		Barcode
	inch	mm	inch	mm	inch	mm	inch	mm	inch	mm	inch	mm	
TBO 30 B	1-1/8	28.6	21/32	16.5	2-1/4	57.1	7/64	2.75	1/4	6.35	1/4	6.35	9314350008182
TBO 30 B 1/2	1-1/8	28.6	21/32	16.5	2-5/8	67	7/64	2.75	1/4	6.35	1/2	12.7	9314350008199
TBO 35 B	1-3/8	35	7/8	22.2	2-1/2	63.5	-	3.15	5/16	8	1/4	6.35	9314350008205
TBO 35 B 1/2	1-3/8	35	7/8	22.2	3	76	-	3.15	5/16	8	1/2	12.7	9314350008212
TBO 50 B 1/2	1-7/8	47	1-5/16	33	3-3/8	86	3/16	4.75	1/2	12.7	1/2	12.7	9314350008229

Replacement bearing TB11

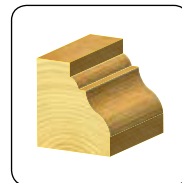
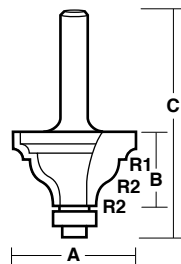

2 Flute - Edge & Draw Face Bit with Ball Bearing Guide - Carbide Tipped

- Can be used as a raised panel bit for panel doors

Product Group R622 **Discount Group** Z0904

Part No.	A		B		C		Shank		Barcode
	inch	mm	inch	mm	inch	mm	inch	mm	
TEF 01 B 1/2	2.6	66	45/64	18	3	76	1/2	12.7	9314350011892

Replacement bearing TB11

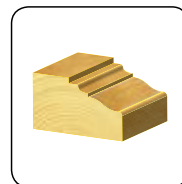
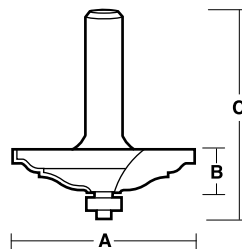

2 Flute - Cove Bit with Pilot

- Used for a drop leaf table joints and decorative edges

Product Group R623 **Discount Group** Z0906

Part No.	A		B		C		E		R Radius		Shank		Barcode
	inch	mm	inch	mm	inch	mm	inch	mm	inch	mm	inch	mm	
HIGH SPEED STEEL													
H 708	11/16	17.4	1/2	12.7	1-7/8	47	3/16	4.8	1/4	6.35	1/4	6.35	9314350006447
H 712	1	25	3/4	19	2	50.8	3/16	4.8	3/8	9.5	1/4	6.35	9314350006454
H 716	1-1/4	32	13/16	20.6	2	50.8	3/16	4.8	1/2	12.7	1/4	6.35	9314350006461

Product Group R624 **Discount Group** Z0904

Part No.	A		B		C		E		R Radius		Shank		Barcode
	inch	mm	inch	mm	inch	mm	inch	mm	inch	mm	inch	mm	
CARBIDE TIPPED													
T 706	9/16	14.2	3/8	9.5	1-5/8	41	3/16	4.8	3/16	4.8	1/4	6.35	9314350006478
T 708	11/16	17.5	9/16	14.2	1-7/8	47	3/16	4.8	1/4	6.35	1/4	6.35	9314350006485
T 712	15/16	24	5/8	15.9	2	50.8	3/16	4.8	3/8	9.5	1/4	6.35	9314350006492
T 716	1-3/16	30	13/16	20.6	2	50.8	3/16	4.8	1/2	12.7	1/4	6.35	9314350006508

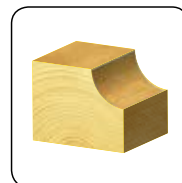
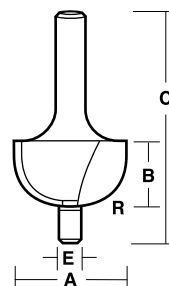

H 712



T 708

2 Flute - Cove Bit with Ball Bearing Guide - Carbide Tipped

- Up, sheer cutting angle clears chip fast for chatter free accurate routing

Product Group R625 Discount Group Z0904

Part No.	A		B		C		R Radius		Shank		Barcode
	inch	mm	inch	mm	inch	mm	inch	mm	inch	mm	
T702 B	5/8	15.9	5/16	7.9	2-3/32	53	1/16	1.6	1/4	6.35	9314350006515
T704 B	3/4	19	1/2	12.7	2-3/32	53	1/8	3.2	1/4	6.35	9314350006522
T706 B	7/8	22.2	1/2	12.7	2-3/32	53	3/16	4.8	1/4	6.35	9314350006539
T708 B	1	25.4	1/2	12.7	2-3/32	53	1/4	6.35	1/4	6.35	9314350006546
T708 B 1/2	1	25.4	1/2	12.7	2-1/2	63.5	1/4	6.35	1/2	12.7	9314350006553
T710 B	1-1/8	28.6	1/2	12.7	2	50.8	5/16	7.9	1/4	6.35	9314350006560
T710 B 1/2	1-1/8	28.6	1/2	12.7	2-5/8	67	5/16	7.9	1/2	12.7	9314350006577
T712 B	1-1/4	31.8	1/2	12.7	2-3/32	53	3/8	9.5	1/4	6.35	9314350006584
T712 B 1/2	1-1/4	31.8	1/2	12.7	2-5/8	67	3/8	9.5	1/2	12.7	9314350006591
T716 B	1-1/2	38.1	5/8	15.9	2-1/4	57.1	1/2	12.7	1/4	6.35	9314350006607
T716 B 1/2	1-1/2	38.1	5/8	15.9	2-3/4	70	1/2	12.7	1/2	12.7	9314350006614
T720 B 1/2	1-3/4	44.5	7/8	22.2	3	76	5/8	15.9	1/2	12.7	9314350006621
T724 B 1/2	2	50.8	7/8	22.2	3-1/4	82	3/4	19	1/2	12.7	9314350006638

Replacement bearing TB11

2 Flute - Classical Cove Bit with Ball Bearing Guide - Carbide Tipped

- For decorative edge moulding
- Use optional TB11 ball bearing for the standard cove design
- Larger TB11 bearing will eliminate bottom bead
- Use routing machines height adjustment to include or exclude top bead

Product Group R626 Discount Group Z0904

Part No.	A		B		C		R Radius		Shank		Barcode
	inch	mm	inch	mm	inch	mm	inch	mm	inch	mm	
TC 708 B	1-1/8	28.6	0.53	13.5	2-1/4	57.1	1/4	6.35	1/4	6.35	9314350006645
TC 708 B 1/2	1-1/8	28.6	0.53	13.5	2-1/2	63.5	1/4	6.35	1/2	12.7	9314350006652
TC 712 B	1-3/8	35	0.67	17	2-1/4	57.1	3/8	9.5	1/4	6.35	9314350006669
TC 712 B 1/2	1-3/8	35	0.67	17	2-3/4	70	3/8	9.5	1/2	12.7	9314350006676
TC 716 B 1/2	1-5/8	41	-	22	3-9/32	83.2	1/2	12.7	1/2	12.7	9314350006683

Replacement bearing TB9

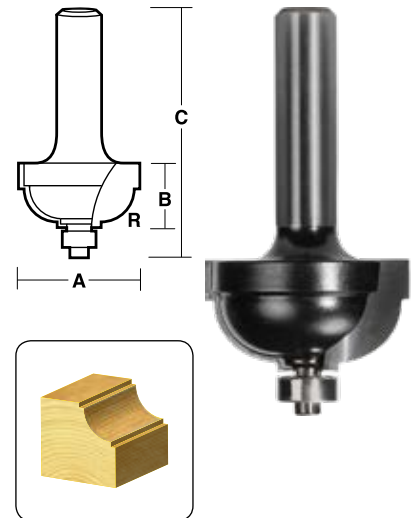
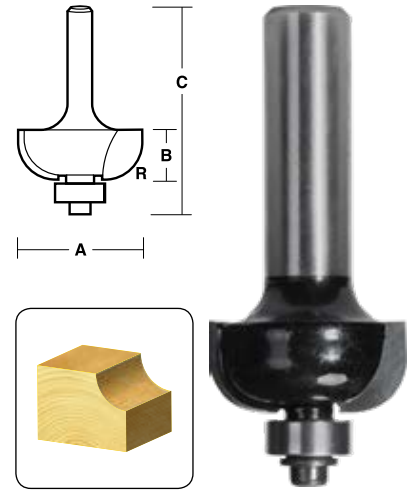

2 Flute – Double Cove Bit with Ball Bearing Guide – Carbide Tipped

- Produces a decorative edge moulding
- Use optional TB11 ball bearing for the standard cove design
- Larger TB11 bearing will eliminate bottom bead
- Use routing machines height adjustment to include or exclude top bead

Product Group R627 **Discount Group** Z0904

Part No.	A		B		C		R1 Radius		R2 Radius		Shank		Barcode
	inch	mm	inch	mm	inch	mm	inch	mm	inch	mm	inch	mm	
TDC 706 B	1-1/2	38.1	3/4	19	2-1/4	57.1	3/16	4.8	1/4	6.35	1/4	6.35	9314350001695
TDC 706 B 1/2	1-1/2	38.1	3/4	19	2-3/4	70	3/16	4.8	1/4	6.35	1/2	12.7	9314350001701
TDC 708 B 1/2	1-3/4	44.4	7/8	22.2	3	76	1/4	6.35	5/16	7.9	1/2	12.7	9314350001718

Replacement bearing TB9

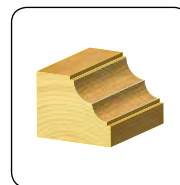
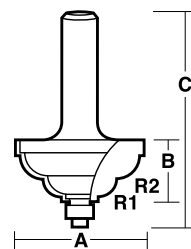

2 Flute – Triple Cove Bit with Ball Bearing Guide – Carbide Tipped

- 3 radii can be used separately or in combination for decorative moulding
- Use optional TB11 ball bearing for the standard cove design
- Larger TB11 bearing will eliminate bottom bead

Product Group R628 **Discount Group** Z0904

Part No.	A		B		C		R1 Radius		R2 Radius		Shank		Barcode
	inch	mm	inch	mm	inch	mm	inch	mm	inch	mm	inch	mm	
TTC 706 B 1/2	1-7/8	47	1	25.4	3-1/4	82	3/16	4.8	1/4	6.35	1/2	12.7	9314350001725
TTC 708 B 1/2	2-1/4	57.1	1-1/8	28.6	3-3/8	86	1/4	6.35	5/16	7.9	1/2	12.7	9314350001732

Replacement bearing TB9

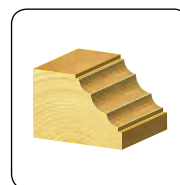
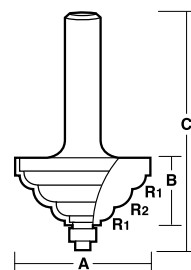

2 Flute – Provincial Bit with Ball Bearing Guide – Carbide Tipped

- For decorative edge moulding
- Versatile combination bit
- Change bearing to include bottom bead
- Use smaller TB9 bearing to expose bottom corner of cutter. This will generate an extra bead (not pictured)
- Reverse profile to classical bit

Product Group R629 **Discount Group** Z0904

Part No.	A		B		C		R Radius		Shank		Barcode
	inch	mm	inch	mm	inch	mm	inch	mm	inch	mm	
TCR 8 B	1	25.4	0.46	11.7	2	50.8	1/8	3.2	1/4	6.35	9314350006812
TCR 8 B 1/2	1	25.4	0.46	11.7	2-5/8	67	1/8	3.2	1/2	12.7	9314350006829
TCR 12 B	1-1/4	31.8	0.56	14.2	2-1/4	57.1	3/16	4.8	1/4	6.35	9314350006836
TCR 12 B 1/2	1-1/4	31.8	0.56	14.2	2-5/8	67	3/16	4.8	1/2	12.7	9314350006843
TCR 16 B 1/2	1-1/2	38.1	0.71	18	2-3/4	70	1/4	6.35	1/2	12.7	9314350006850

Replacement bearing TB11

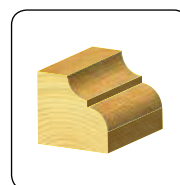
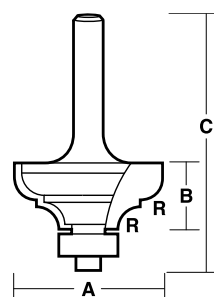

2 Flute – Provincial Bit with Ball Bearing Guide – Carbide Tipped

- For decorative edge moulding
- Versatile combination bit
- Incorporates small top radius and large bottom radius

Product Group R630 **Discount Group** Z0904

Part No.	A		B		C		R1 Radius		R2 Radius		Shank		Barcode
	inch	mm	inch	mm	inch	mm	inch	mm	inch	mm	inch	mm	
TCRA16 B	1 1/4	31.8	19/32	15	2-1/4	57.2	1/4	6.4	1/8	3.2	1/4	6.35	9314350016477
TCRA16 B 1/2	1 1/4	31.8	19/32	15	2-5/8	66.7	1/4	6.4	1/8	3.2	1/2	12.7	9314350016484
TCRA32 B 1/2	2	50.8	15/16	23.8	3-1/4	82.6	1/2	12.7	1/4	6.25	1/2	12.7	9314350016538

Replacement bearing TB11

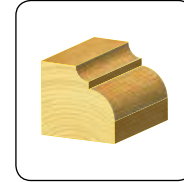
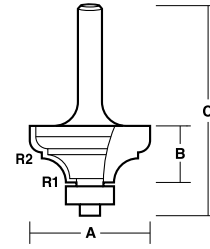

2 Flute – Classical Bit with Ball Bearing Guide – Carbide Tipped

- Versatile decorative moulding for furniture and building applications
- Use as a combination bit by only including part profile

Product Group R631 **Discount Group** Z0904

Part No.	A		B		C		R Radius		Shank		Barcode
	inch	mm	inch	mm	inch	mm	inch	mm	inch	mm	
TC8 B	1-1/8	28.6	1/2	12.7	2	50.8	1/8	3.2	1/4	6.35	9314350006867
TC8 B 1/2	1-1/8	28.6	1/2	12.7	2-1/2	63.5	1/8	3.2	1/2	12.7	9314350006874

Product Group R632 **Discount Group** Z0904

Part No.	A		B		C		R Radius		Shank		Barcode
	inch	mm	inch	mm	inch	mm	inch	mm	inch	mm	
TC12 B	1-3/8	35	5/8	15.9	2-1/4	57.1	3/16	4.8	1/4	6.35	9314350006881
TC12 B 1/2	1-3/8	35	5/8	15.9	2-3/4	70	3/16	4.8	1/2	12.7	9314350006898

Product Group R633 **Discount Group** Z0904

Part No.	A		B		C		R Radius		Shank		Barcode
	inch	mm	inch	mm	inch	mm	inch	mm	inch	mm	
TC16 B 1/2	15/8	41	-	22	3-9/32	83.2	1/4	6.35	1/2	12.7	9314350006904

R631, R632, R633 – Replacement bearing TB11

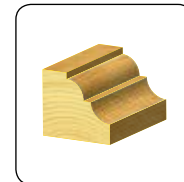
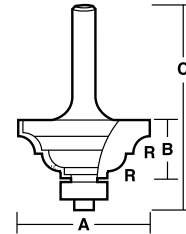

TC 8 B

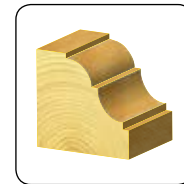

TC 12 B

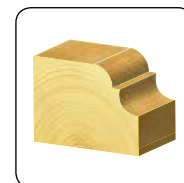

TC 16 B 1/2



2 Flute - Traditional Classical Bit with Ball Bearing Guide - Carbide Tipped

- This bit produces a traditional style furniture moulding
- TTC 8B to TTC12 B 1/2 incorporate large top radius and small bottom radius

Product Group **Discount Group**
R634 Z0904

Part No.	A		B1		B2		C		R1	R2	Shank		Barcode
	inch	mm	inch	mm	inch	mm	inch	mm	mm	mm	inch	mm	
TTC 8 B	1	25.4	7/16	11.1	5/64	2	2-1/8	54	3.2	2	1/4	6.35	9314350001848
TTC 8 B 1/2	1	25.4	7/16	11.1	5/64	2	2-1/2	63.5	3.2	2	1/2	12.7	9314350001855
TTC 12 B	1-1/4	31.8	7/16	11.1	5/64	2	2-1/8	54	4.8	3.5	1/4	6.35	9314350001862
TTC 12 B 1/2	1-1/4	31.8	7/16	11.1	5/64	2	2-9/16	65	4.8	3.5	1/2	12.7	9314350001879
TTC 16 B	1-1/2	38.1	9/16	14.3	1/8	3.2	2-1/4	57.1	6.35	6.35	1/4	6.35	9314350001886
TTC 16 B 1/2	1-1/2	38.1	9/16	14.3	1/8	3.2	2-3/4	70	6.35	6.35	1/2	12.7	9314350001893

Replacement bearing TB11

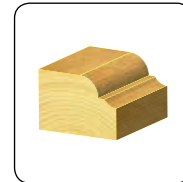
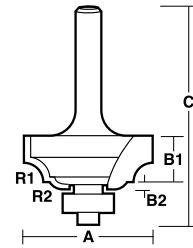

2 Flute - Chamfering Bit with Pilot

- Helpful in making almost invisible joints

Product Group **Discount Group**
R635 Z0906

Part No.	A		B		C		E		Shank		Barcode	
	inch	mm	inch	mm	inch	mm	inch	mm	inch	mm		
HIGH SPEED STEEL												
H 916	1	25.4	5/8	15.9	1-7/8	47	3/16	4.8	1/4	6.35	9314350006959	

Product Group **Discount Group**
R636 Z0904

Part No.	A		B		C		E		Shank		Barcode	
	inch	mm	inch	mm	inch	mm	inch	mm	inch	mm		
CARBIDE TIPPED												
T 916	1-3/16	30.2	45/64	18.0	1.94	49.5	3/16	4.8	1/4	6.35	9314350006966	

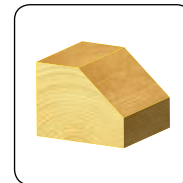
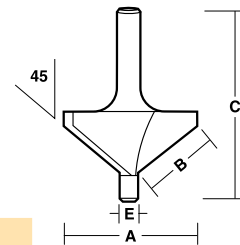

2 Flute - Chamfering Bit with Ball Bearing Guide - Carbide Tipped

- Wide range of angles available
- Most can be modified to achieve custom angles

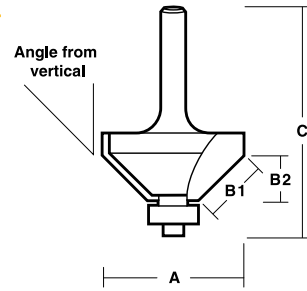

Product Group R637
Discount Group Z0904

Part No.	A		B1		B2		C		Shank		Barcode
	inch	mm	inch	mm	inch	mm	inch	mm	inch	mm	
5° ANGLE FROM VERTICAL											
T 8105 B 1/2	47/64	18.5	127/64	36.1	-	36	3 5/8	92.1	1/2	12.7	9314350020146

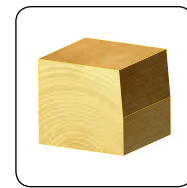

Product Group R638
Discount Group Z0904

Part No.	A		B1		B2		C		Shank		Barcode
	inch	mm	inch	mm	inch	mm	inch	mm	inch	mm	
10° ANGLE FROM VERTICAL											
T 8110 B 1/2	63/64	24.9	17/16	36.5	-	36	3 5/8	92.1	1/2	12.7	9314350020153

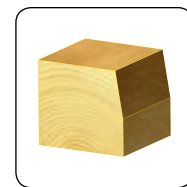

Product Group R639
Discount Group Z0904

Part No.	A		B1		B2		C		Shank		Barcode
	inch	mm	inch	mm	inch	mm	inch	mm	inch	mm	
22.5° ANGLE FROM VERTICAL											
T 8122 B	1	25.4	21/32	16.5	39/64	15.5	2-1/4	57.1	1/4	6.35	9314350006973
T 8122 B 1/2	1	25.4	21/32	16.5	39/64	15.5	2-3/4	70	1/2	12.7	9314350006980
TX 8122 B 1/2	1.42	36	1-1/4	32	-	28.4	3-1/4	82	1/2	12.7	9314350009325

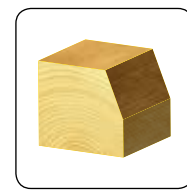

Product Group R640
Discount Group Z0904

Part No.	A		B1		B2		C		Shank		Barcode
	inch	mm	inch	mm	inch	mm	inch	mm	inch	mm	
30° ANGLE FROM VERTICAL											
T 8130 B	1-1/8	28.6	43/64	17	35/64	13.9	2-1/4	57.1	1/4	6.35	9314350006997
T 8130 B 1/2	1-1/8	28.6	43/64	17	35/64	13.9	2-3/4	70	1/2	12.7	9314350007000



Product Group R641
Discount Group Z0904

Part No.	A		B1		B2		C		Shank		Barcode
	inch	mm	inch	mm	inch	mm	inch	mm	inch	mm	
45° ANGLE FROM VERTICAL											
T 916 B	1-3/8	35	5/8	15.9	29/64	11.4	2-1/4	57.1	1/4	6.35	9314350007017
T 916 B 1/2	1-3/8	35	5/8	15.9	29/64	11.4	2-3/4	70	1/2	12.7	9314350007024
T 920 B 1/2	1-7/8	47.6	1	25.4	11/16	17.5	2-3/4	70	1/2	12.7	9314350007031
T 924 B 1/2	2-1/4	57.1	1-1/4	31.8	-	22.5	3-1/4	82	1/2	12.7	9314350007048

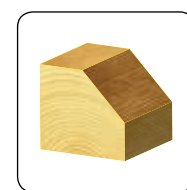

R637-R641 - Replacement bearing TB11

2 Flute - Chamfering Bit with Ball Bearing Guide - Carbide Tipped

- Wide range of angles available
- Most can be modified to achieve custom angles

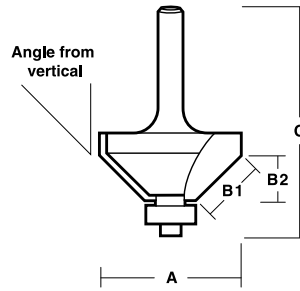

Product Group R642
Discount Group Z0904

Part No.	A		B1		B2		C		Shank		Barcode
	inch	mm	inch	mm	inch	mm	inch	mm	inch	mm	
65° ANGLE FROM VERTICAL											
T 8165 B	1.58	40	5/8	15.9	1/4	6.35	2-3/32	53	1/4	6.35	9314350010772
T 8165 B 1/2	1.58	40	5/8	15.9	1/4	6.35	2-1/2	63.5	1/2	12.7	9314350010789
TX 8165 B 1/2	2.95	75	1-3/8	35	-	14.5	2-3/4	70	1/2	12.7	9314350010758

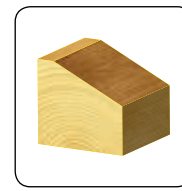

Product Group R643
Discount Group Z0904

Part No.	A		B1		B2		C		Shank		Barcode
	inch	mm	inch	mm	inch	mm	inch	mm	inch	mm	
80° ANGLE FROM VERTICAL											
T 8180 B	1.58	40	9/16	14.3	3/32	2.4	2-1/4	50.8	1/4	6.35	9314350010796
T 8180 B 1/2	1.58	40	9/16	14.3	3/32	2.4	2-1/2	63.5	1/2	12.7	9314350010802
TX 8180 B 1/2	2.95	75	1-1/4	32	7/32	5.5	2-9/16	65	1/2	12.7	9314350010765

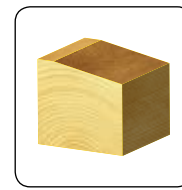

2 Flute - Inverted Chamfering Bit - Carbide Tipped

- Used for chamfering the bottom of boards

Product Group R644
Discount Group Z0904

Part No.	A		B1		B2		C		Shank		Barcode
	inch	mm	inch	mm	inch	mm	inch	mm	inch	mm	
T 916 B 1/2	1 3/4	44.5	-	22.5	5/8	15.9	3	76.3	1/2	12.7	9314350020160

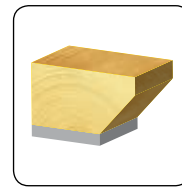
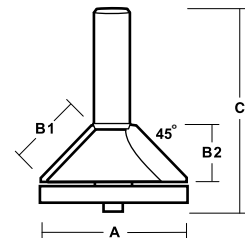

Replacement bearing TBS 9

2 Flute – Rebating Bit with Pilot

- Pilot equipped bits do not require a guide when making rebating cuts
- Use for picture frames, window frames box making, general rebate work

Product Group **Discount Group**
R645 Z0906

Part No.	A		B		C		E		D Depth		Shank		Barcode
	inch	mm	inch	mm	inch	mm	inch	mm	inch	mm	inch	mm	
H1708	11/16	17.5	7/16	11.1	1-7/8	47	3/16	4.8	1/4	6.35	1/4	6.35	9314350007055
H1712	15/16	23.8	1/2	12.7	2	50.8	3/16	4.8	3/8	9.5	1/4	6.35	9314350007062

Product Group **Discount Group**
R646 Z0904

Part No.	A		B		C		E		D Depth		Shank		Barcode
	inch	mm	inch	mm	inch	mm	inch	mm	inch	mm	inch	mm	
T1708	11/16	17.5	7/16	11.1	2	50.8	3/16	4.8	1/4	6.35	1/4	6.35	9314350001916
T1712	15/16	23.8	1/2	12.7	2	50.8	3/16	4.8	3/8	9.5	1/4	6.35	9314350001923

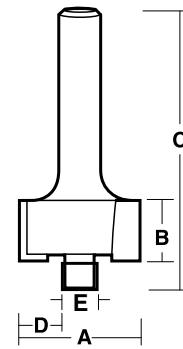

H 1708

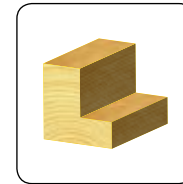

T 1708

2 Flute – Rebating Bit with Pilot with Ball Bearing Guide – Carbide Tipped

- Has ball bearing guide for mar-free finish
- By substituting TB-9 bearing, the depth of the rebate will be increased by 1/16" (1.6mm)

Product Group **Discount Group**
R647 Z0904

Part No.	A		B		C		D Depth		Shank		Barcode
	inch	mm	inch	mm	inch	mm	inch	mm	inch	mm	
T1708 B	1	25.4	1/2	12.7	2	50.8	1/4	6.35	1/4	6.35	9314350007079
T1708 B 1/2	1	25.4	1/2	12.7	2-1/2	63	1/4	6.35	1/2	12.7	9314350007086
T1712 B	1-1/4	31.7	1/2	12.7	2-1/4	57	3/8	9.5	1/4	6.35	9314350007093
T1712 B 1/2	1-1/4	31.7	1/2	12.7	2-1/2	63	3/8	9.5	1/2	12.7	9314350007109
TX1712 B 1/2	1-1/4	31.7	1	25.4	3	76.2	3/8	9.5	1/2	12.7	9314350015869
T1716 B 1/2	1-1/2	38.1	1/2	12.7	2-9/16	65	1/2	12.7	1/2	12.7	9314350007116
T1720 B 1/2	1-3/4	44.5	1/2	12.7	2-9/16	65	5/8	15.9	1/2	12.7	9314350007123

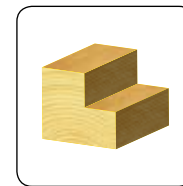
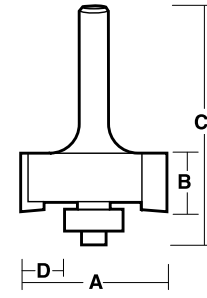

Replacement bearing TB11

Shielded Bearings

- These bearings can be fitted to the rebating bits to give a range of cut depths
- Custom size shielded bearings can be made upon request

Product Group **Discount Group**
R648 Z0904

Part No.	OD		ID		B		Barcode
	inch	mm	inch	mm	inch	mm	
TBS1	3/4	19	3/16	4.8	3/16	4.8	9314350014978
TBS2	7/8	22.2	3/16	4.8	3/16	4.8	9314350014985
TBS3	1	25.4	3/16	4.8	3/16	4.8	9314350014992
TBS4	11/8	28.6	3/16	4.8	3/16	4.8	9314350015005
TBS5	11/4	31.8	3/16	4.8	3/16	4.8	9314350015012
TBS6	13/8	34.9	3/16	4.8	3/16	4.8	9314350015029
TBS7	11/2	38.1	3/16	4.8	3/16	4.8	9314350015036
TBS8	15/8	41.3	3/16	4.8	3/16	4.8	9314350015043
TBS9	13/4	44.5	3/16	4.8	3/16	4.8	9314350015050

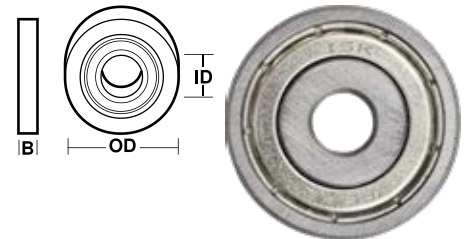

2 Flute - Chamfering and Radius Bit with Ball Bearing Guide

Product Group R649 **Discount Group** Z0904

Part No.	A		B		C		R Radius		Shank		Barcode
	inch	mm	inch	mm	inch	mm	inch	mm	inch	mm	
TRR 10 B 1/2	1.57	40	0.458	11.6	2-1/2	63.5	0.156	3.9	1/2	12.7	9314350011908
TRR 16 B 1/2	2.4	60.9	0.53	13.5	2-9/16	65	0.156	3.9	1/2	12.7	9314350012219

Replacement bearing TB11

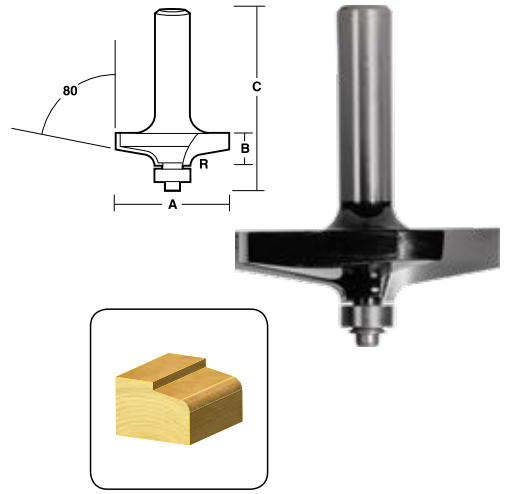

2 Flute - Bull Nose Radius Bit with Ball Bearing Guide - Carbide Tipped

- Round over both sides of board in one pass
- Can be modified to convert to drawing line bit

Product Group R650 **Discount Group** Z0904

Part No.	A		B1		B2		C		Shank		Barcode
	inch	mm	inch	mm	inch	mm	inch	mm	inch	mm	
WITH BEARING											
TBN 2 B	25/32	19.8	1/2	12.7	5/32	4	2	50.8	1/4	6.35	9314350007154
TBN 2 B 1/2	25/32	19.8	1/2	12.7	5/32	4	2-1/2	63.5	1/2	12.7	9314350007161
TBN 4.5 MB 1/2	51/64	20.4	1/2	12.7	11/64	4.5	2-1/2	63.5	1/2	12.7	9314350014329
TBN 5 MB 1/2	53/64	20.9	1/2	12.7	13/64	5	2-1/2	63.5	1/2	12.7	9314350014961
TBN 3 B	27/32	21.4	1/2	12.7	7/32	5.5	2	50.8	1/4	6.35	9314350007178
TBN 3 B 1/2	27/32	21.4	1/2	12.7	7/32	5.5	2-1/2	63.5	1/2	12.7	9314350007185
TBN 4 B	29/32	23	3/4	19	9/32	7.1	2-3/8	60	1/4	6.35	9314350007192
TBN 4 B 1/2	29/32	23	3/4	19	9/32	7.1	2-3/4	70	1/2	12.7	9314350007208
TBN 6 B	1-1/32	26.2	3/4	19	13/32	10.3	2-3/8	60	1/4	6.35	9314350007215
TBN 6 B 1/2	1-1/32	26.2	3/4	19	13/32	10.3	2-3/4	70	1/2	12.7	9314350007222
TBN 8 B 1/2	1-5/32	29.4	1	25.4	17/32	13.5	3	76	1/2	12.7	9314350007239
TBN 10 B 1/2	1-9/32	32.6	1-3/32	27.8	21/32	16.7	3-1/4	82	1/2	12.7	9314350007246
TBN 12 B 1/2	1-13/32	35.8	1-1/4	31.8	25/32	19.8	3-1/4	82	1/2	12.7	9314350007253
TBN 15 B 1/2	1-21/32	42	1-1/2	38.1	1-1/32	26.2	3-5/8	92	1/2	12.7	9314350007260
TBN 32 MB 1/2	1-57/64	48	1-39/64	40.6	1-17/64	32	3-7/8	98.4	1/2	12.7	9314350014954

Replacement bearing TB8

Product Group R651 **Discount Group** Z0904

Part No.	A		B1		B2		C		Shank		Barcode
	inch	mm	inch	mm	inch	mm	inch	mm	inch	mm	
WITHOUT BEARING											
TBN 4 1/2	29/32	23	3/4	19	9/32	7.1	2	64	1/2	12.7	9314350020177

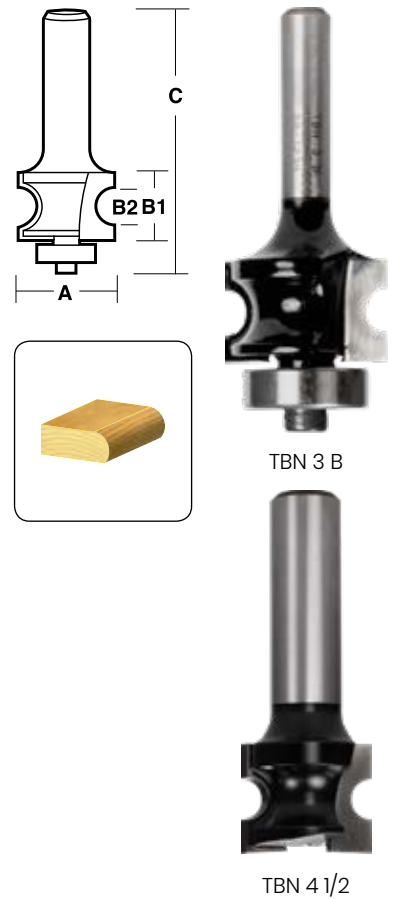

ROUTER BITS



Canoe Slat Bit with Ball Bearing Guide

- Canoe slat bit or "Slat Wall Bits" produce a variation on lap joints
- Use with TBN4 B, TBN4 B 1/2 or TBN 4 1/2 (without bearing) as a matching cutter

Product Group	Discount Group
R652	Z0904

Part No.	A		B		C		Shank		Barcode
	inch	mm	inch	mm	inch	mm	inch	mm	
TCO1B	57/64	22.6	9/32	7.1	1 3/4	44.5	1/4	6.35	9314350015074
TCO1B 1/2	57/64	22.6	9/32	7.1	2 3/8	60.3	1/2	12.7	9314350015067

Replacement bearing TB11

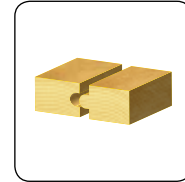
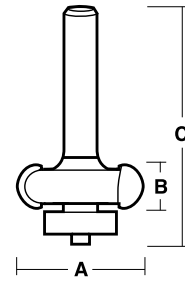

2 Flute - Drawing Line Bit -with Ball Bearing Guide - Carbide Tipped

- A popular mould
- Common on old style double hung windows and architraves

Product Group	Discount Group
R653	Z0904

Part No.	A		B1		B2		C		Shank		Barcode
	inch	mm	inch	mm	inch	mm	inch	mm	inch	mm	
TDL 3 B	0.85	21.6	7/16	11.1	7/32	5.5	2	50.8	1/4	6.35	9314350007277
TDL 3 B 1/2	0.85	21.6	7/16	11.1	7/32	5.5	2-1/2	63.5	1/2	12.7	9314350007284
TDL 4 B	0.91	23.1	19/32	15	9/32	7.1	2-3/32	53	1/4	6.35	9314350007291
TDL 4 B 1/2	0.91	23.1	19/32	15	9/32	7.1	2-3/4	70	1/2	12.7	9314350007307
TDL 6 B	1.035	26.3	11/16	17.5	13/32	10.3	2-1/4	57.1	1/4	6.35	9314350007314
TDL 6 B 1/2	1.035	26.3	11/16	17.5	13/32	10.3	2-3/4	70	1/2	12.7	9314350007321

Replacement bearing TB8

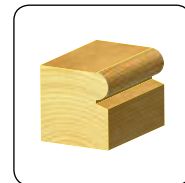
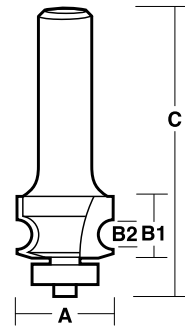

2 Flute - Stair Handrail Bit with Ball Bearing Guide - Carbide Tipped

- This bit will produce an attractive and functional hand rail for balustrades
- It can be used in conjunction with the half bull nose bit to curve the top over*

Product Group	Discount Group
R654	Z0904

Part No.	A		B		C		Shank		Barcode
	inch	mm	inch	mm	inch	mm	inch	mm	
THR 50 B 1/2	2	50.8	2 1/4	57.1	4.5	116	1/2	12.7	9314350008526

*This will produce an optional profile

Replacement bearing TB8

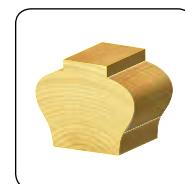
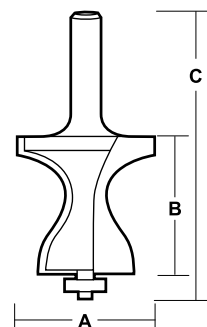

Use THBN 75 B1/2 for curved top



2 Flute – Stair Handrail Bit with Ball Bearing Guide – Carbide Tipped

- This bit will produce an attractive and functional hand rail for balustrades
- It can be used in conjunction with the half bull nose bit to curve the top over*

Product Group R655 **Discount Group** Z0904

Part No.	A		B		C		Shank		Barcode
	inch	mm	inch	mm	inch	mm	inch	mm	
THR 40 B 1/2	2-5/16	58.7	-	38.7	3-13/16	96.8	1/2	12.7	9314350014688
THR 60 B 1/2	2-1/8	54	2	50.8	4.3	110	1/2	12.7	9314350008533

*This will produce an optional profile
Replacement bearing TB8

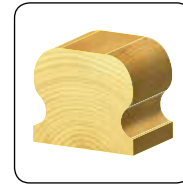
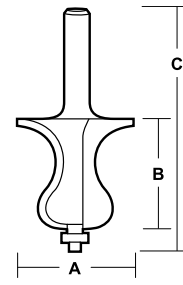

2 Flute – Half Bull Nose Radius Bit with Ball Bearing Guide – Carbide Tipped

- A handy bit for finishing wider timbers
- The adjustment of machine height gives a variety of different forms

Product Group R656 **Discount Group** Z0904

Part No.	A		B1		B2		C		Radius	Shank		Barcode
	inch	mm	inch	mm	inch	mm	inch	mm	mm	inch	mm	
THBN 45 B 1/2	1	25.4	118	30	1.41	36	3-5/8	92	45	1/2	12.7	9314350007338
THBN 60 B 1/2	1-1/16	27	-	42.3	1-13/16	46	4-3/32	104	60	1/2	12.7	9314350007345
THBN 75 B 1/2	1-1/8	28.6	2	50.8	2-1/4	57.1	4-3/8	111.5	75	1/2	12.7	9314350007352

Replacement bearing TB16

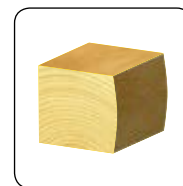
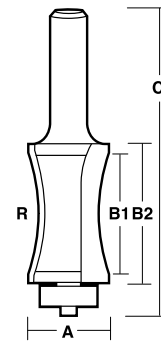

2 Flute – Roman Ogee Bit with Pilot

- A decorative edge bit for early American furniture making
- Reverse profile to Ogee bit

Product Group R657 **Discount Group** Z0906

Part No.	A		B		C		R Radius		Shank		Barcode
	inch	mm	inch	mm	inch	mm	inch	mm	inch	mm	
HIGH SPEED STEEL											
H 5705	3/4	19	1/2	12.7	1-7/8	47	5/32	4	1/4	6.35	9314350006690
H 5708	1-1/4	31.8	3/4	19	2	50.8	1/4	6.35	1/4	6.35	9314350006706

Product Group R658 **Discount Group** Z0904

Part No.	A		B		C		R Radius		Shank		Barcode
	inch	mm	inch	mm	inch	mm	inch	mm	inch	mm	
CARBIDE TIPPED											
T 5705	3/4	19	1/2	12.7	1-7/8	47	5/32	4	1/4	6.35	9314350001749
T 5708	1-1/4	31.8	3/4	19	2	50.8	1/4	6.35	1/4	6.35	9314350001756

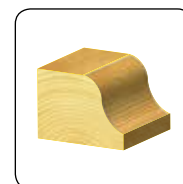
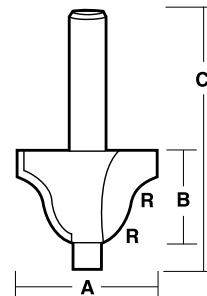

H 5705



T 5705

ROUTER BITS



2 Flute – Roman Ogee Bit with Ball Bearing Guide – Carbide Tipped

- A decorative edge bit for early American furniture making
- Reverse profile to Ogee bit

Product Group **Discount Group**
R659 Z0904

Part No.	A		B		C		R Radius		Shank		Barcode
	inch	mm	inch	mm	inch	mm	inch	mm	inch	mm	
T5705 B	1-1/8	28.6	1/2	12.7	2	50.8	5/32	4	1/4	6.35	9314350006713
T5705 B 1/2	1-1/8	28.6	1/2	12.7	2-5/8	67	5/32	4	1/2	12.7	9314350006720

Replacement bearing TB11

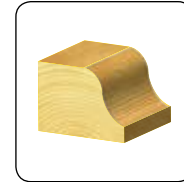
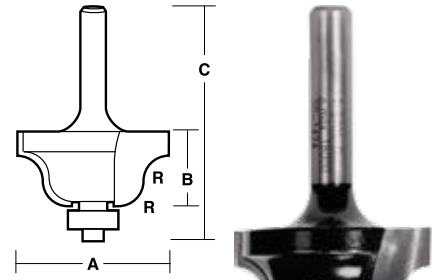

Product Group **Discount Group**
R660 Z0904

Part No.	A		B		C		R Radius		Shank		Barcode
	inch	mm	inch	mm	inch	mm	inch	mm	inch	mm	
T5708 B	1-1/2	38.1	3/4	19	2-3/8	60	1/4	6.35	1/4	6.35	9314350006737
T5708 B 1/2	1-1/2	38.1	3/4	19	2-3/4	70	1/4	6.35	1/2	12.7	9314350006744
T5712 B 1/2	2	50.8	1	25.4	3-3/8	86	3/8	9.5	1/2	12.7	9314350006751

Replacement bearing TB11

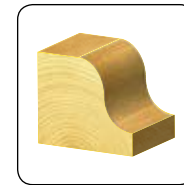
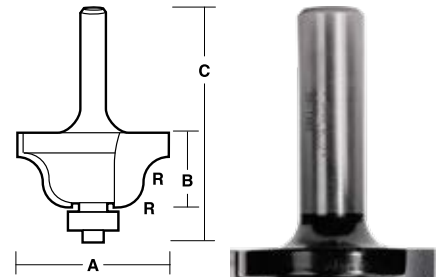

2 Flute – Double Ogee Bit with Ball Bearing Guide – Carbide Tipped

- Decorative edge bit for furniture making
- Use machine height adjustment to vary profile

Product Group **Discount Group**
R661 Z0904

Part No.	A		B		C		R Radius		Shank		Barcode
	inch	mm	inch	mm	inch	mm	inch	mm	inch	mm	
TDO8 B	1-1/4	31.8	0.575	14.6	2-3/16	55	1/8	3.2	1/4	6.35	9314350011762
TDO8 B 1/2	1-1/4	31.8	0.575	14.6	2-5/8	67	1/8	3.2	1/2	12.7	9314350011779
TDO12 B 1/2	1-5/8	41	0.763	19.4	2-3/4	70	3/16	4.8	1/2	12.7	9314350011786
TDO16 B 1/2	2	50.8	0.95	24.1	3	76	1/4	6.35	1/2	12.7	9314350011793

Replacement bearing TB11

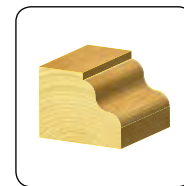
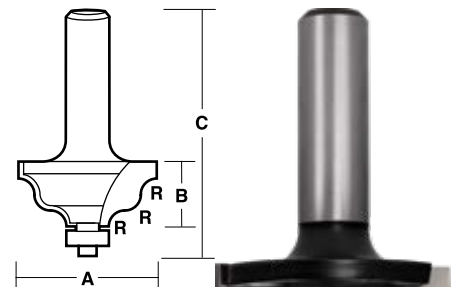

**2 Flute – Ogee Bit with Ball Bearing Guide
– Carbide Tipped**

- Produces a decorative form used widely on table and mantle edges
- Can be used as a combination bit
- Use machine height adjustment to include or exclude top bead
- By fitting the optional TB9 ball bearing, a 1/16" edge bead can be produced as illustrated

Product Group R662 **Discount Group** Z0904

Part No.	A		B		C		R Radius		Shank		Barcode
	inch	mm	inch	mm	inch	mm	inch	mm	inch	mm	
T7506 B	1-3/8	34.9	0.65	16.5	2-5/16	58.7	3/16	4.8	1/4	6.35	9314350006768
T7506 B 1/2	1-3/8	34.9	0.65	16.5	2-25/32	70.7	3/16	4.8	1/2	12.7	9314350006775

Replacement bearing TB11

Product Group R663 **Discount Group** Z0904

Part No.	A		B		C		R Radius		Shank		Barcode
	inch	mm	inch	mm	inch	mm	inch	mm	inch	mm	
T7508 B	1-5/8	41	3/4	19	2-1/4	57.1	1/4	6.35	1/4	6.35	9314350006782
T7508 B 1/2	1-5/8	41	3/4	19	2-3/4	70	1/4	6.35	1/2	12.7	9314350006799

Replacement bearing TB11

Product Group R664 **Discount Group** Z0904

Part No.	A		B		C		R Radius		Shank		Barcode
	inch	mm	inch	mm	inch	mm	inch	mm	inch	mm	
T7512 B 1/2	2-1/8	54	1	25.4	3-3/8	86	3/8	9.5	1/2	12.7	9314350006805

Replacement bearing TB11

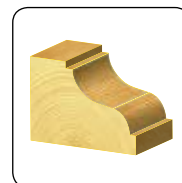
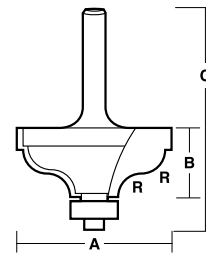
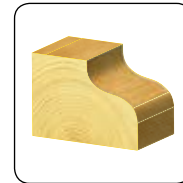
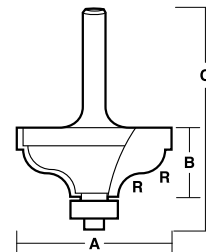
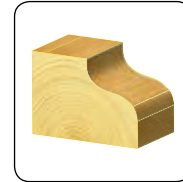
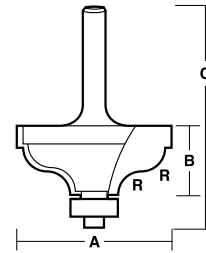

TB9 Bearing Fitted

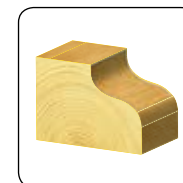

TB11 Bearing Fitted

ROUTER BITS



2 Flute – Shallow Roman Ogee Bit – Carbide Tipped

- This bit will produce a decorative edge moulding

Product Group	Discount Group
R665	Z0904

Part No.	A		B1		B2		C		Radius	Shank		Barcode
	inch	mm	inch	mm	inch	mm	inch	mm		inch	mm	
TS 5705 B	1-1/4	32	3/8	9.5	5/32	4	2	50.8	4	1/4	6.35	9314350008465
TS 5705 B 1/2	1-1/4	32	3/8	9.5	5/32	4	2-3/8	60	4	1/2	12.7	9314350008472
TS 5708 B 1/2	1-5/8	41	7/16	11.1	1/4	6.35	2-1/2	63.5	6.3	1/2	12.7	9314350008489
TS 5712 B 1/2	2	50.8	9/16	14.3	3/8	9.5	2-5/8	67	9.5	1/2	12.7	9314350008496

Replacement bearing TB11

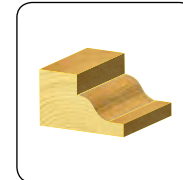
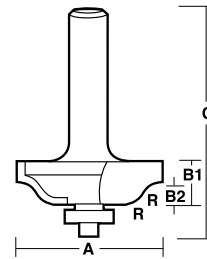

2 Flute – Batten Mould Bit with Ball Bearing Guide – Carbide Tipped

- Enables production of batten moulding
- Used for the fixing of cement sheeting and other types of wall paneling

Product Group	Discount Group
R667	Z0904

Part No.	A		B1		B2		C		Shank		Barcode
	inch	mm	inch	mm	inch	mm	inch	mm	inch	mm	
TBM 33 B 1/2	1-1/8	28.6	1.3	33	7/8	22.2	3-5/8	92	1/2	12.7	9314350001909

Replacement bearing TB8

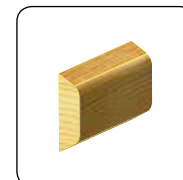
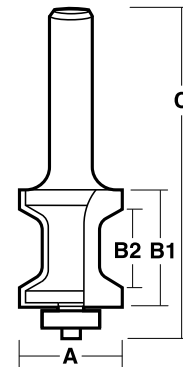

2 Flute – Table Edge Bit with Ball Bearing Guide – Carbide Tipped

- A popular bit for finishing table edges

Product Group	Discount Group
R668	Z0904

Part No.	A		B		C		R1 Radius	R2 Radius	Shank		Barcode		
	inch	mm	inch	mm	inch	mm	inch	mm	inch	mm			
TEB 14 B 1/2	2	50.8	1	25.4	3-1/8	79	-	8	-	16	1/2	12.7	9314350007130

Replacement bearing TB11

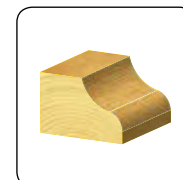
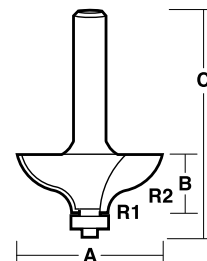

2 Flute – Table Edge Bit with Return & Ball Bearing Guide – Carbide Tipped

- This bit has a return to round over the bottom of a table for an attractive finish

Product Group		Discount Group											
R669		Z0904											
Part No.	A		B		C		R1 Radius		R2 Radius		Shank		Barcode
	inch	mm	inch	mm	inch	mm	inch	mm	inch	mm	inch	mm	
TEB15 B 1/2	2	50.8	1-5/16	33.5	-	94.7	-	6.35	-	16	1/2	12.7	9314350007147
TEB16 B 1/2	2	50.8	-	36.7	3-27/32	97.6	-	8	-	16	1/2	12.7	9314350020184

Replacement bearing TB11

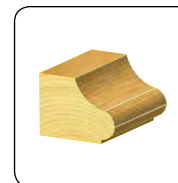
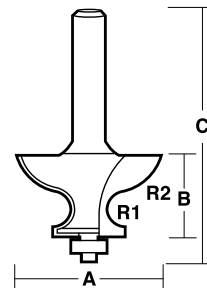

4 Flute – Double Edge Radius Bit with Ball Bearing Guide – Carbide Tipped

- For rounding of the top and bottom edges of timber at the same time
- Assembly comes with bearing, spacer and washers that allow you to cut up to 30mm thick material
- 4 flute cutters for longer cutting life

Product Group		Discount Group											
R670		Z0904											
Part No.	A		B		C		R Radius		Shank		Barcode		
	inch	mm	inch	mm	inch	mm	inch	mm	inch	mm			
COMPLETE TOOL													
TDA 194-3 MB1/2	-	28	-	15-32	-	97.8	-	3	1/2	12.7	9314350020191		
TDA 194-5 MB1/2	-	32	-	19-36	-	97.8	-	5	1/2	12.7	9314350008700		
TDA 194-8 MB1/2	-	38	-	25-39	-	97.8	-	8	1/2	12.7	9314350020243		

Product Group		Discount Group				
R671		Z0904				
Part No.	A	R Radius	Barcode			
	mm	mm				
CUTTER ONLY – TOP						
T 194-3 M RH	28	3	9314350020207			
T 194-5 M RH	32	5	9314350007772			
T 194-8 M RH	38	8	9314350020221			
CUTTER ONLY – BOTTOM						
T 194-3 M LH	28	3	9314350020214			
T 194-5 M LH	32	5	9314350007802			
T 194-8 M LH	38	8	9314350020238			



T 194-3 M RH



T 194-3 M LH

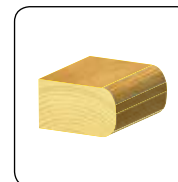
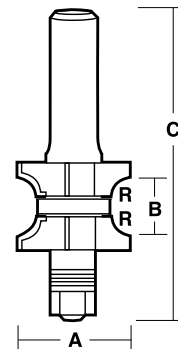

TDA 194-5 MB 1/2

Wood Thickness	Space Between Cutters
10	Nil (no Brg.)
19	Brg. + 2 Washers
22	Brg. + 5 Washers
25	Brg. + Spacer
30	Brg. + Spacer & 5 Washers

Replacement bearing TB12 - Replacement arbor TA20



**2 Flute - Reed Bit with Ball Bearing Guide
- Carbide Tipped**

- Single Reed Bits will produce a single bead on the edge of the material
- Double Reed Bits give a combination of two beads on the material
- Multiple Reed Bits give a combination of four beads on the material

Part No.	A		B1		B2		C		Shank		Barcode
	inch	mm	inch	mm	inch	mm	inch	mm	inch	mm	
TRS 3 B 1/2	0.885	21.6	0.397	10	7/32	5.5	2-1/2	63.5	1/2	12.7	9314350008380
TRD 3 B 1/2	0.855	21.6	5/8	15.9	7/32	5.5	2-3/4	70	1/2	12.7	9314350008397
TRM 3 B 1/2	0.855	21.6	1.16	29.5	7/32	5.5	3-1/4	82	1/2	12.7	9314350008403

Replacement bearing TB8

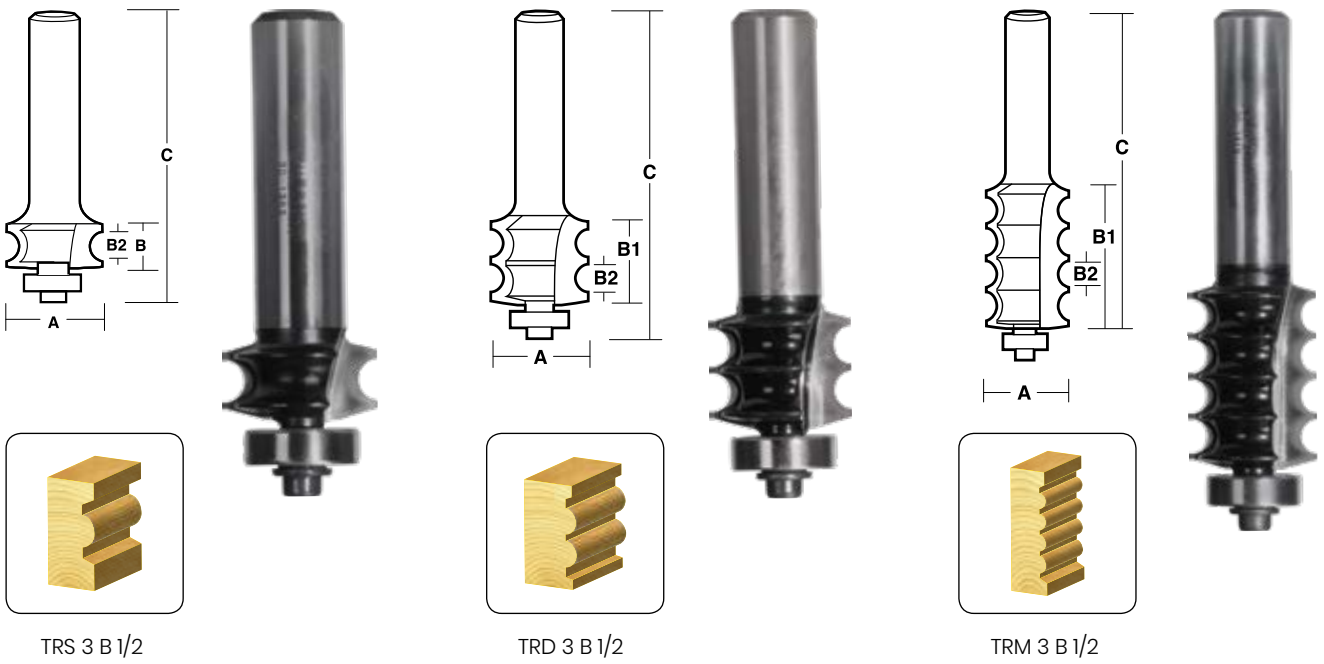

TRS 3 B 1/2

TRD 3 B 1/2

TRM 3 B 1/2

2 Flute - Classical Combination Bit with Ball Bearing Guide - Carbide Tipped

- This combination bit will cut a multitude of different shapes
- Any part can be selected, multiple passes will also increase variety of shapes
- Highly versatile cutter

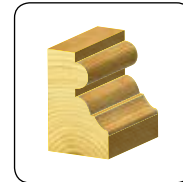
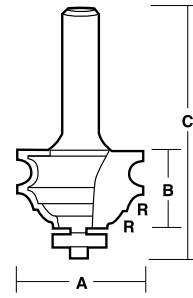

Product Group R673 **Discount Group** Z0904

Part No.	A		B		C		R Radius		Bearing No.	Shank		Barcode
	inch	mm	inch	mm	inch	mm	inch	mm		inch	mm	
TCB 50 B 1/2	1-21/32	42	1-3/16	30	3-5/8	92	3/16	4.8	TB16	1/2	12.7	9314350007406
TCB 60 B 1/2	1-21/32	42	1-3/16	30	3-5/8	92	3/16	4.8	TB14	1/2	12.7	9314350007413

2 Flute - Multi Form Combination Bit with Ball Bearing Guide - Carbide Tipped

- This combination bit will cut a multitude of different shapes
- Any part can be selected, multiple passes will also increase variety of shapes
- Highly versatile cutter

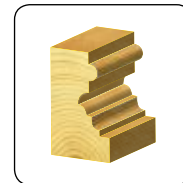
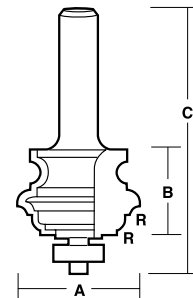

Product Group R674 **Discount Group** Z0904

Part No.	A		B		C		R Radius		Bearing No.	Shank		Barcode
	inch	mm	inch	mm	inch	mm	inch	mm		inch	mm	
TCB 500 B 1/2	1.65	41.9	1-5/16	33.3	3-3/4	95	3/16	4.8	TB16	1/2	12.7	9314350001947
TCB 600 B 1/2	1.65	41.9	1-5/16	33.3	3-5/8	92	3/16	4.8	TB14	1/2	12.7	9314350001954

SOLID SURFACE BITS

ROUTER BITS

2 Flute – Countertop Bit with Ball Bearing Guide – No Drip Design

- A range of cutters for machining solid surface materials
- Fitted with a Carbi-Smooth bearing assembly to protect the surface material

Product Group R675 **Discount Group** Z0904

Part No.	A		B		C		Shank		Barcode
	inch	mm	inch	mm	inch	mm	inch	mm	
TSS1B1/2	-	25.4	-	22.9	-	82	1/2	12.7	9314350007987

Replacement bearing TBT21

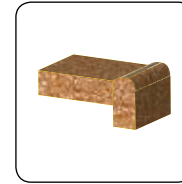
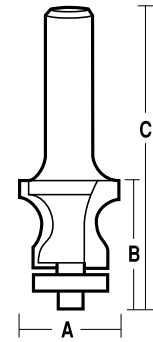

2 Flute – Countertop Bit – No Drip Design

- A range of cutters for machining solid surface materials

Product Group R676 **Discount Group** Z0904

Part No.	A		B		C		R Radius		Shank		Barcode
	inch	mm	inch	mm	inch	mm	inch	mm	inch	mm	
TSS 2	-	19	-	9.3	-	41	-	6.35	1/4	6.35	9314350008175
TSS 2 1/2	-	19	-	9.3	-	54	-	6.35	1/2	12.7	9314350007970

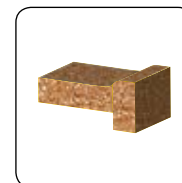
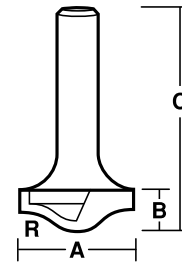

2 Flute – Countertop Bit with Ball Bearing Guide

- No drip design
- A range of cutters for machining solid surface materials
- Fitted with a Carbi-Smooth bearing assembly to protect the surface material

Product Group R677 **Discount Group** Z0904

Part No.	A		B		C		R Radius		Shank		Barcode
	inch	mm	inch	mm	inch	mm	inch	mm	inch	mm	
TSS 3 B	-	28.6	-	13.5	-	60	-	6.35	1/4	6.35	9314350007994
TSS 3 B 1/2	-	28.6	-	13.5	-	73	-	6.35	1/2	12.7	9314350008007

Replacement bearing TBT20

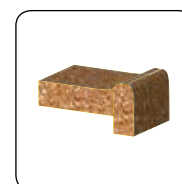
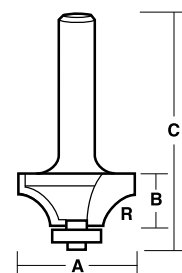

2 Flute – Bevel Undermount Bowl Bit with Ball Bearing Guide

- No drip design
- A range of cutters for machining solid surface materials
- Fitted with a Carbi-Smooth bearing assembly to protect the surface material

Product Group		Discount Group									
R678		Z0904									
Part No.	A		B		C		Shank		Barcode		
	inch	mm	inch	mm	inch	mm	inch	mm			
TSS 4 B 1/2	-	35	-	32	-	88	1/2	12.7	9314350008014		

Replacement bearing TBT15

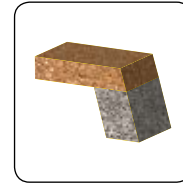
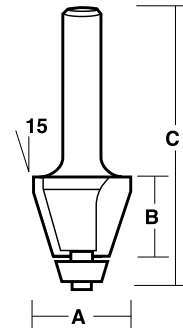

2 Flute – Roman Ogee Undermount Bowl Bit with Ball Bearing Guide

- No drip design
- A range of cutters for machining solid surface materials
- Fitted with a Carbi-Smooth bearing assembly to protect the surface material

Product Group		Discount Group											
R679		Z0904											
Part No.	A		B		C		R1 Radius		R2 Radius		Shank		Barcode
	inch	mm	inch	mm	inch	mm	inch	mm	inch	mm	inch	mm	
TSS 5 B 1/2	-	50.8	-	25.4	-	85	5/32	-	3/8	-	1/2	12.7	9314350008021

Replacement bearing TBT19

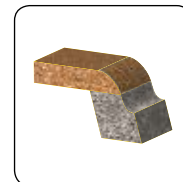
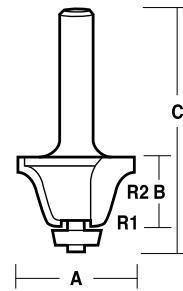

2 Flute – Rounding Over Undermount Bowl Bit with Ball Bearing Guide

- No drip design
- A range of cutters for machining solid surface materials
- Fitted with a Carbi-Smooth bearing assembly to protect the surface material

Product Group		Discount Group									
R680		Z0904									
Part No.	A		B		C		R Radius		Shank		Barcode
	inch	mm	inch	mm	inch	mm	inch	mm	inch	mm	
TSS 6 B 1/2	-	44.5	-	25.4	-	85	-	9.5	1/2	12.7	9314350008038

Replacement bearing TBT19

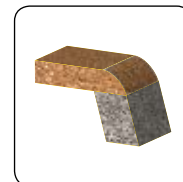
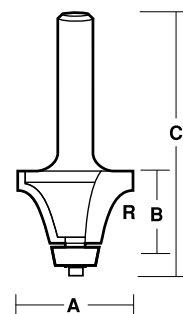

SOLID SURFACE BITS

ROUTER BITS

2 Flute - Inverted Rounding Over Bit with Ball Bearing Guide

- Ball bearing guide

Product Group R681 **Discount Group** Z0904

Part No.	A		B		C		R Radius		Shank		Barcode
	inch	mm	inch	mm	inch	mm	inch	mm	inch	mm	
TSS 7 B 1/2	-	60.3	-	22.2	-	80	-	16	1/2	12.7	9314350008045
TSS 9 B 1/2	-	66.7	-	24.1	-	82	-	19	1/2	12.7	9314350008069

Replacement bearing TB15

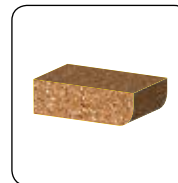
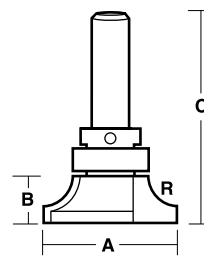

2 Flute - Rounding Over Bit with Ball Bearing Guide

- Fitted with a Carbi-Smooth bearing assembly to protect the surface material

Product Group R686 **Discount Group** Z0904

Part No.	A		B		C		R Radius		Shank		Barcode
	inch	mm	inch	mm	inch	mm	inch	mm	inch	mm	
TSS 8 B 1/2	-	47.6	-	20.6	-	80	-	16	1/2	12.7	9314350008052
TSS 10 B 1/2	-	54	-	25.4	-	84	-	19	1/2	12.7	9314350008076

Replacement bearing TBT20

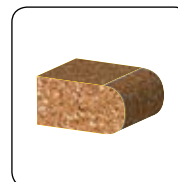
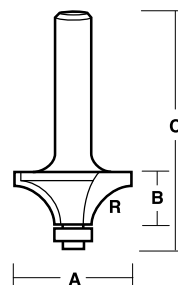

2 Flute - Face Inlay Bit with Ball Bearing Guide

- Fitted with a Carbi-Smooth bearing assembly to protect the surface material

Product Group R682 **Discount Group** Z0904

Part No.	A		B		C		G	Bearing Assembly**	Shank		Barcode
	inch	mm	inch	mm	inch	mm	mm		inch	mm	
TSS 11 B 1/2	-	25.4	1/4	-	-	66	1.6	TBT22	1/2	12.7	9314350008083
TSS 21 B 1/2	-	25.4	1/4	-	-	66	3.2	TBT21	1/2	12.7	9314350009288
TSS 31 B 1/2	-	25.4	1/4	-	-	66	4.8	TBT20	1/2	12.7	9314350009295
TSS 12 B 1/2	-	25.4	1/2	-	-	73	1.6	TBT22	1/2	12.7	9314350008090
TSS 22 B 1/2	-	25.4	1/2	-	-	73	3.2	TBT21	1/2	12.7	9314350009301
TSS 32 B 1/2	-	25.4	1/2	-	-	72	4.8	TBT20	1/2	12.7	9314350009318

**Please refer to page 172

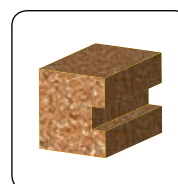
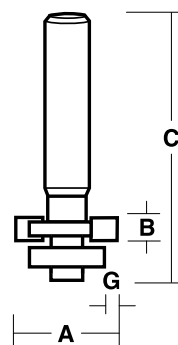

6 Flute - Surface Planer - Carbide Tipped

- Suits all timbers
- Popular for timber "slab milling"

Product Group **Discount Group**
R687 Z0904

Part No.	A		B		C		Shank		Barcode
	inch	mm	inch	mm	inch	mm	inch	mm	
TSS13 1/2	-	50.8	-	9.5	-	80	1/2	12.7	9314350008106

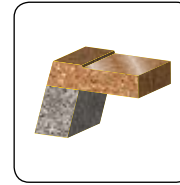
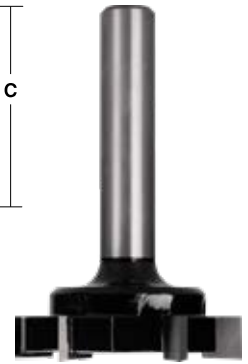
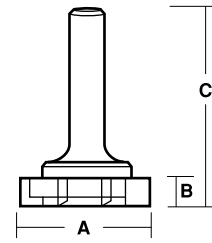

ROUTER BITS

2 Flute - Chamfer Bit 15° with Ball Bearing Guide

- Shank end bearing cutter for undermount sinks

Product Group **Discount Group**
R683 Z0904

Part No.	A		B1		B2		C		Shank		Barcode
	inch	mm	inch	mm	inch	mm	inch	mm	inch	mm	
TSS14 B 1/2	-	28.6	-	25.4	-	28.4	-	85	1/2	12.7	9314350008113

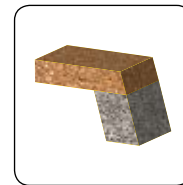
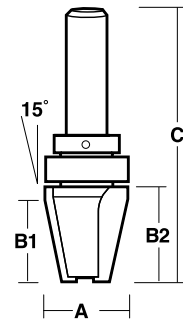

Replacement bearing TB18
Retaining ring TZR 3

2 Flute - Bowl Cutter 15° with Ball Bearing Guide - Carbide Tipped

- For undermount sink applications

Product Group **Discount Group**
R688 Z0904

Part No.	A		B1		B2		C		Shank		Barcode
	inch	mm	inch	mm	inch	mm	inch	mm	inch	mm	
TSS15 B 1/2	-	28.6	-	23.5	-	25.4	-	85	1/2	12.7	9314350008120

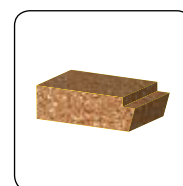
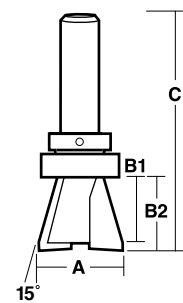

Replacement bearing TB18
Retaining ring TZR 3

SOLID SURFACE BITS

2 Flute - Countertop Bit - Carbide Tipped

- Contemporary edge profile for countertops

Product Group	Discount Group
R684	Z0904

Part No.	A		B		C		Shank		Barcode
	inch	mm	inch	mm	inch	mm	inch	mm	
TSS16 1/2	-	23.8	-	9.5	-	54	1/2	12.7	9314350008137

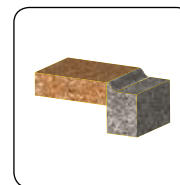
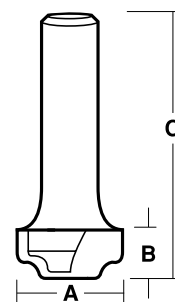

2 Flute - Bevel Bit - Carbide Tipped

Product Group	Discount Group
R689	Z0904

Part No.	A		B1		B2		C		Shank		Barcode
	inch	mm	inch	mm	inch	mm	inch	mm	inch	mm	
TSS17 1/2	-	25.4	-	25.4	-	28.4	-	79.4	1/2	12.7	9314350008144

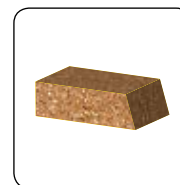
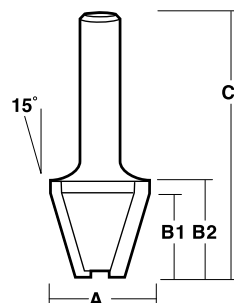

2 Flute - Overhang Trim Bit with Ball Bearing Guide

- Fitted with a Carbi-Smooth bearing assembly to protect the surface material

Product Group	Discount Group
R685	Z0904

Part No.	A		B		C		Shank		Barcode
	inch	mm	inch	mm	inch	mm	inch	mm	
TSS18 B 1/2	-	19	-	25.9	-	87	1/2	12.7	9314350008151

Replacement bearing TBT19

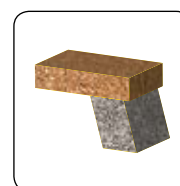
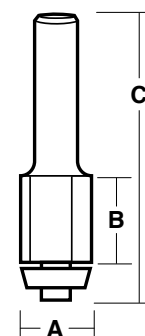

SOLID SURFACE BITS



2 Flute - Flush Trim Bit with Ball Bearing Guide - Carbide Tipped

- Fitted with a Carbi-Smooth bearing assembly to protect the surface material

Product Group		Discount Group		A		B		C		Shank		Barcode
Part No.		inch	mm	inch	mm	inch	mm	inch	mm	inch	mm	
R690	Z0904	-	19	-	25.9	-	87	1/2	12.7	9314350008168		

Replacement bearing TBT21

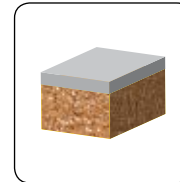
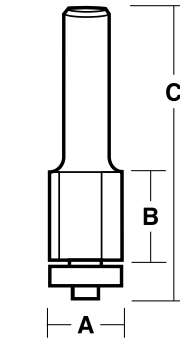

FACE MOULDING BITS

WOOD

2 Flute - Face Moulding Bit with Ball Bearing Guide - Carbide Tipped

- For window sills, skirting boards, architraves, picture frames etc
- Can be used as a combination bit by partial inclusion of form

Product Group		Discount Group		A		A1	B		C		Shank		Barcode
Part No.		inch	mm	inch	mm	inch	mm	inch	mm	inch	mm	inch	
R691	Z0904	-	17.8	1-1/4	31.8	1-5/16	33	3-3/8	86	1/2	12.7	9314350008366	

Replacement bearing TB11

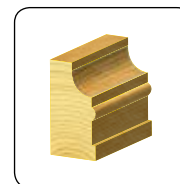
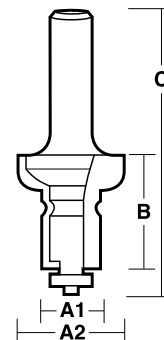

2 Flute - Face Moulding Bit with Ball Bearing Guide - Carbide Tipped

- For window sills, skirting boards, architraves, picture frames etc

Product Group		Discount Group		A		A1	B		C		Shank		Barcode
Part No.		inch	mm	inch	mm	inch	mm	inch	mm	inch	mm	inch	
R695	Z0904	1/2	12.7	1-1/4	31.8	1-5/16	33	3-3/8	86	1/2	12.7	9314350008373	

Replacement bearing TB11

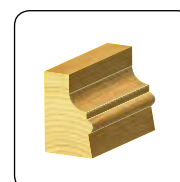
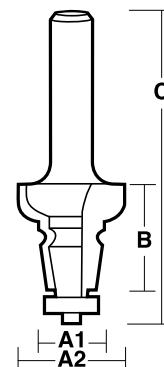

ROUTER BITS



2 Flute – Face Moulding Bit with Ball Bearing Guide – Carbide Tipped

- For window sills, skirting boards, architraves, picture frames etc

Product Group R692 **Discount Group** Z0904

Part No.	A		B		C		Shank		Barcode
	inch	mm	inch	mm	inch	mm	inch	mm	
TFM 06 B 1/2	0.945	24	1-7/16	36.5	3-1/2	89	1/2	12.7	9314350001961

Replacement bearing TB8

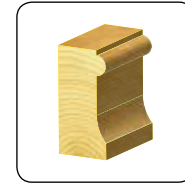
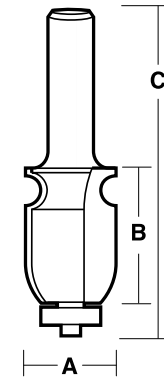

2 Flute – Face Moulding Bit with Ball Bearing Guide – Carbide Tipped

- For window sills, skirting boards, architraves, picture frames etc

Product Group R696 **Discount Group** Z0904

Part No.	A		B		C		Shank		Barcode
	inch	mm	inch	mm	inch	mm	inch	mm	
TFM 12 B 1/2	0.945	24	1-7/16	36.5	3-1/2	89	1/2	12.7	9314350001978

Replacement bearing TB8

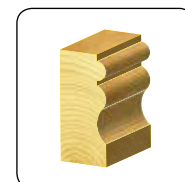
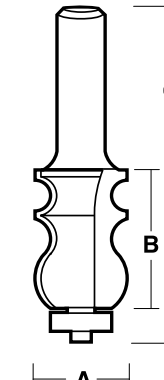

2 Flute – Face Moulding Bit with Ball Bearing Guide – Carbide Tipped

- For window sills, skirting boards, architraves, picture frames etc

Product Group R693 **Discount Group** Z0904

Part No.	A		B		C		Shank		Barcode
	inch	mm	inch	mm	inch	mm	inch	mm	
TFM 18 B 1/2	0.945	24	1-7/16	36.5	3-1/2	89	1/2	12.7	9314350001985

Replacement bearing TB8

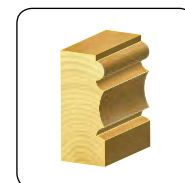
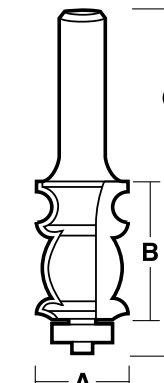

2 Flute - Face Moulding Bit with Ball Bearing Guide - Carbide Tipped

- For window sills, skirting boards, architraves, picture frames etc

Product Group		Discount Group								
R697		Z0904								
Part No.	A		B		C		Shank		Barcode	
	inch	mm	inch	mm	inch	mm	inch	mm		
TFM 24 B1/2	1	25.4	1-7/8	47.6	4	102	1/2	12.7	9314350001992	

Replacement bearing TB8

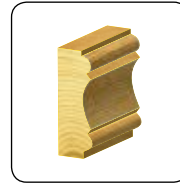
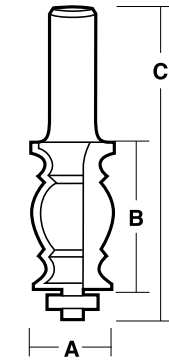

2 Flute - Face Moulding Bit with Ball Bearing Guide - Carbide Tipped

- For window sills, skirting boards, architraves, picture frames etc
- Extremely popular skirting board profile

Product Group		Discount Group								
R694		Z0904								
Part No.	A		B		C		Shank		Barcode	
	inch	mm	inch	mm	inch	mm	inch	mm		
TFM 30 B1/2	1-3/4	44.5	1-1/2	38.1	4	102	1/2	12.7	9314350002005	

Replacement bearing TB12

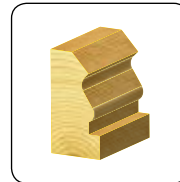
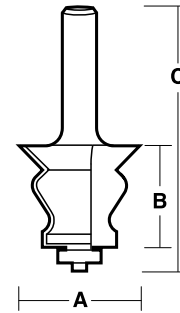

2 Flute - Face Moulding Bit with Ball Bearing Guide - Carbide Tipped

- For window sills, skirting boards, architraves, picture frames etc
- Extremely popular skirting board profile

Product Group		Discount Group								
R698		Z0904								
Part No.	A		B		C		Shank		Barcode	
	inch	mm	inch	mm	inch	mm	inch	mm		
TFM 32 B1/2	1-3/4	44.4	1-7/8	48	4-1/8	105	1/2	12.7	93143500011915	

Replacement bearing TB8

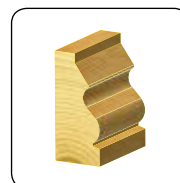
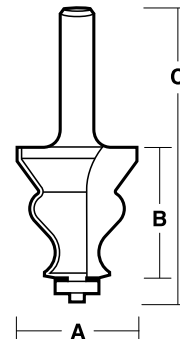

2 Flute – Face Moulding Bit with Ball Bearing Guide – Carbide Tipped

- For window sills, skirting boards, architraves, picture frames etc

Product Group **Discount Group**
R699 Z0904

Part No.	A		B		C		Shank		Barcode
	inch	mm	inch	mm	inch	mm	inch	mm	
TFM 36 B 1/2	1-1/2	38.1	1-5/8	41.3	3-5/8	92	1/2	12.7	9314350002012

Replacement bearing TB8

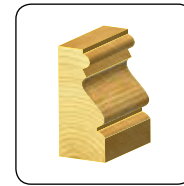
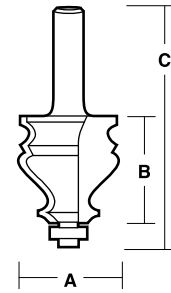

2 Flute – Face Moulding Bit with Ball Bearing Guide – Carbide Tipped

- For window sills, skirting boards, architraves, picture frames etc

Product Group **Discount Group**
R703 Z0904

Part No.	A		B		C		Shank		Barcode
	inch	mm	inch	mm	inch	mm	inch	mm	
TFM 42 B 1/2	1-1/2	38.1	1-5/8	41.3	3-5/8	92	1/2	12.7	9314350002029

Replacement bearing TB8

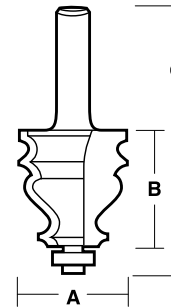

2 Flute – Face Moulding Bit with Ball Bearing Guide – Carbide Tipped

- For window sills, skirting boards, architraves, picture frames etc

Product Group **Discount Group**
R700 Z0904

Part No.	A		B		C		Shank		Barcode
	inch	mm	inch	mm	inch	mm	inch	mm	
TFM 48 B 1/2	1-1/8	28.6	1-5/8	41.3	3-13/16	96.5	1/2	12.7	9314350002036

Replacement bearing TB8

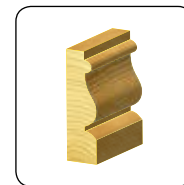
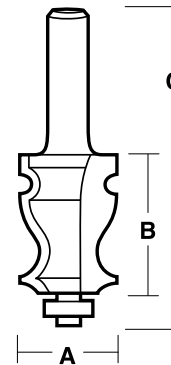

2 Flute - Face Moulding Bit with Ball Bearing Guide - Carbide Tipped

• For window sills, skirting boards, architraves, picture frames etc

<i>Product Group</i>		<i>Discount Group</i>								
R704		Z0904								
Part No.	A		B		C		Shank		Barcode	
	inch	mm	inch	mm	inch	mm	inch	mm		
TFM 54 B1/2	1-1/8	28.6	1-5/8	41.3	3-5/8	92	1/2	12.7	9314350002043	

Replacement bearing TB8

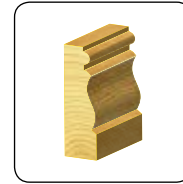
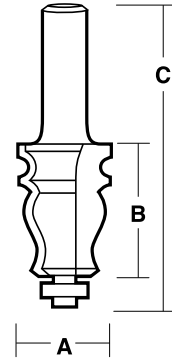

2 Flute - Face Moulding Bit with Ball Bearing Guide - Carbide Tipped

• For window sills, skirting boards, architraves, picture frames etc

<i>Product Group</i>		<i>Discount Group</i>								
R701		Z0904								
Part No.	A		B		C		Shank		Barcode	
	inch	mm	inch	mm	inch	mm	inch	mm		
TFM 60 B1/2	1-5/8	41.3	1-3/4	44.5	3-7/8	98	1/2	12.7	9314350002050	

Replacement bearing TB8

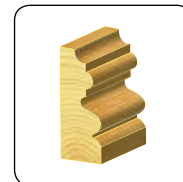
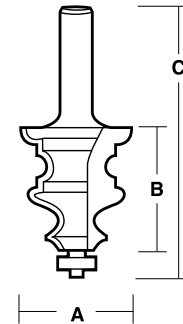

2 Flute - Face Moulding Bit with Ball Bearing Guide - Carbide Tipped

• For window sills, skirting boards, architraves, picture frames etc

<i>Product Group</i>		<i>Discount Group</i>								
R705		Z0904								
Part No.	A		B		C		Shank		Barcode	
	inch	mm	inch	mm	inch	mm	inch	mm		
TFM 66 B1/2	1-1/8	28.6	2-1/4	57.1	4-3/8	111.5	1/2	12.7	9314350002067	

Replacement bearing TB8

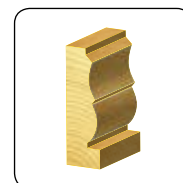
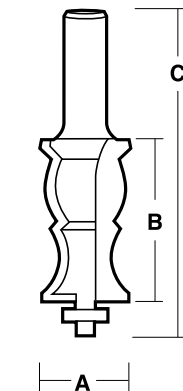

2 Flute – Face Moulding Bit with Ball Bearing Guide – Carbide Tipped

- For window sills, skirting boards, architraves, picture frames etc

Product Group R702 **Discount Group** Z0904

Part No.	A		B		C		Shank		Barcode
	inch	mm	inch	mm	inch	mm	inch	mm	
TFM 72 B 1/2	1-1/8	28.6	2-1/4	57.1	4-3/8	111.5	1/2	12.7	9314350002074

Replacement bearing TB8

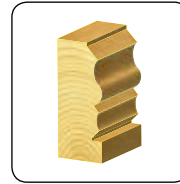
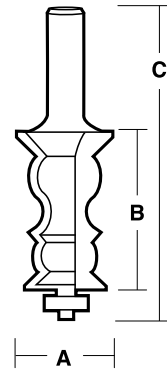

2 Flute – Face Moulding Bit with Ball Bearing Guide – Carbide Tipped

- For window sills, skirting boards, architraves, picture frames etc

Product Group R706 **Discount Group** Z0904

Part No.	A		B		C		Shank		Barcode
	inch	mm	inch	mm	inch	mm	inch	mm	
TFM 80 B 1/2	1-1/4	31.8	2-1/4	57.1	4-3/8	111.5	1/2	12.7	9314350007956

Replacement bearing TB8

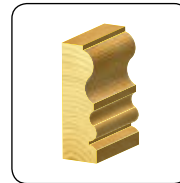
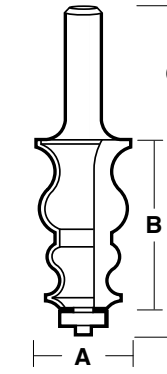

2 Flute – Regency Bit with Ball Bearing Guide – Carbide Tipped

- Highlights the ends of protruding boards such as mantle supports

Product Group R707 **Discount Group** Z0904

Part No.	A		B1		B2		C		Shank		Barcode
	inch	mm	inch	mm	inch	mm	inch	mm	inch	mm	
TDR 33 B 1/2	3/4	19	1-5/16	33	1.07	27.2	3-3/8	86	1/2	12.7	9314350001824

Replacement bearing TB8

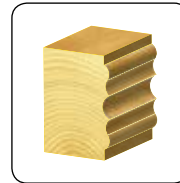
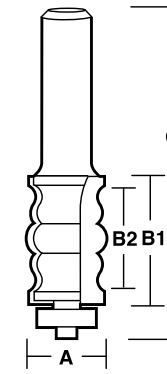

2 Flute - Single Regency Bit with Ball Bearing Guide - Carbide Tipped

- Highlights the ends of protruding boards such as mantle supports

Product Group R709 **Discount Group** Z0904

Part No.	A		B1		B2		C		Shank		Barcode
	inch	mm	inch	mm	inch	mm	inch	mm	inch	mm	
TSR 33 B 1/2	15/16	23.9	1-5/16	33	45/64	17.8	3-5/8	92	1/2	12.7	9314350001817

Replacement bearing TB8

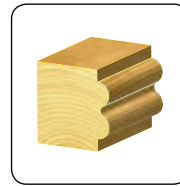
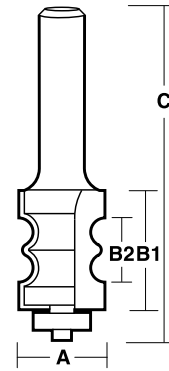

2 Flute - Surface Beading Bit with Ball Bearing Guide - Carbide Tipped

- Highlights the ends of protruding boards such as mantle supports

Product Group R708 **Discount Group** Z0904

Part No.	A		B1		B2		C		Shank		Barcode
	inch	mm	inch	mm	inch	mm	inch	mm	inch	mm	
TSB 33 B 1/2	3/4	19	1-5/16	33	5/8	15.9	3-3/8	86	1/2	12.7	9314350001831

Replacement bearing TB8

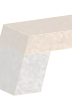
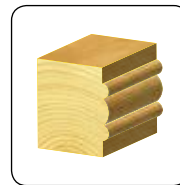
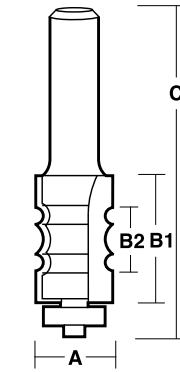

Finger Joint Bit - Carbide Tipped - With Ball Bearing Guide

- Produces a very strong joint due to the extended glue line
- Cutters are removable allowing for a range of joint thickness
- Allows for joints in timber between 11mm & 36mm thick
- Supplied with 5 finger slot cutters

Product Group	Discount Group
R710	Z0904

Part No.	A		B		C		Shank		Barcode
	inch	mm	inch	mm	inch	mm	inch	mm	
TAFJ 90 B 1/2	-	40	-	30	3-7/8	98.6	1/2	12.7	9314350016521
TFJS 90	-	40	Finger Slot Cutter		9314350016613				
TFJE 90	-	39.6	Abutting Edge Cutter		9314350016620				

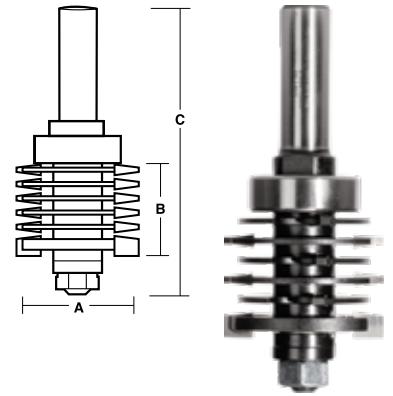

Replacement arbor TA23
Replacement bearing TB3
Replacement spacer TZP-2

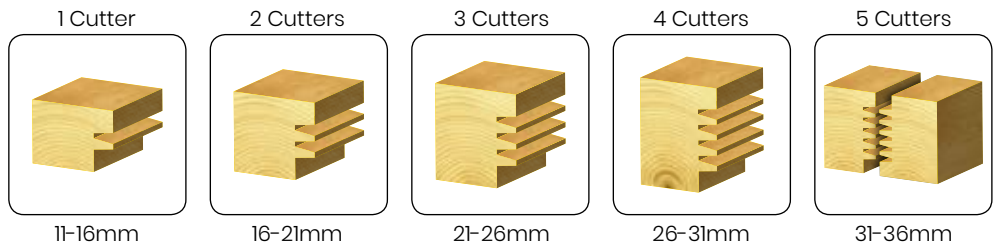

Finger Joint Bit - Two Wing - Carbide Tipped

- For large board, spline and scarf, mortise and tenon joints
- Supplied with three 2-wing cutters as shown, additional cutters may be added*
- Large surface area contact of each component for strong glue joint

Product Group	Discount Group
R711	Z0904

Part No.	A1		A2		B1		B2		C		Shank		Barcode
	inch	mm	inch	mm	inch	mm	inch	mm	inch	mm	inch	mm	
TAFJ 60 1/2	2-1/2	63.5	-	13.6	15/16	23.5	-	7.62	3-5/8	92	1/2	12.7	9314350008632
TFG 60	2-1/2	63.5	-	13.6	11/32	8.5	-	7.62	Cutter only		9314350008649		

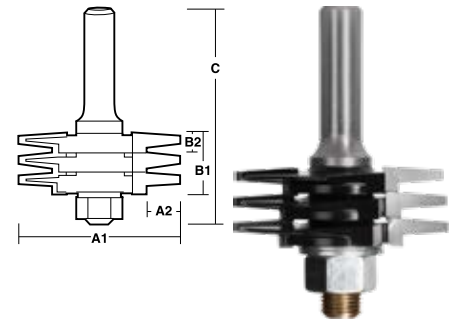

Replacement arbor TA21

*Instructional sheet available upon request

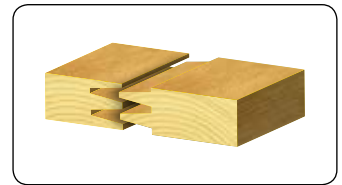

2 Flute - Tongue & Groove Bit - Carbide Tipped

- This bit makes professional hard to detect tongue and groove joints
- One bit only is required, simply invert second piece of timber for matching joints

Product Group	Discount Group
R712	Z0904

Part No.	A		B		C		T Min		T Max		Shank		Barcode
	inch	mm	inch	mm	inch	mm	inch	mm	inch	mm	inch	mm	
TGA 100 1/2	1-3/4	44.5	1-5/32	29.4	3-1/8	79	15/32	12	1-9/64	29.0	1/2	12.7	9314350007420

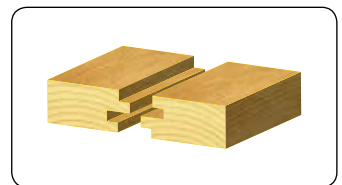
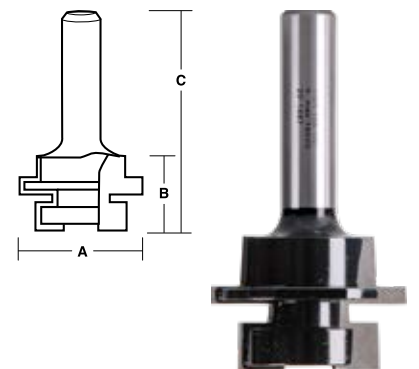

2 Flute - Tongue & Groove Bit - Carbide Tipped

- This bit makes professional hard to detect tongue and groove joints
- One bit only is required, simply invert second piece of timber for matching joins
- Style B allows for stronger glue join due to greater surface area contact

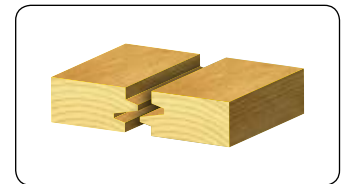
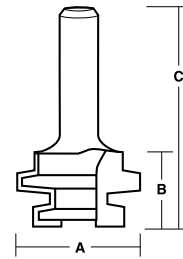

Product Group	Discount Group
R713	Z0904

Part No.	A		B		C		T Min		T Max		Shank		Barcode
	inch	mm	inch	mm	inch	mm	inch	mm	inch	mm	inch	mm	
TGB 50	1.18	30	63/64	25	2-1/4	57.1	7/16	11.1	22.2	22.2	1/4	6.35	9314350007437
TGB 50 1/2	1.18	30	63/64	25	2-1/4	57.1	7/16	11.1	22.2	22.2	1/2	12.7	9314350007444
TGB 100 1/2	1-3/4	44.4	1-5/32	29.4	3-1/4	82	5/8	15.9	27.8	27.8	1/2	12.7	9314350007451
TGB 200 1/2	1-3/4	44.4	2	50.8	4	102	11/16	17.5	49.2	49.2	1/2	12.7	9314350007468

2 Flute - Tongue & Groove Bit for Wall Panel - Carbide Tipped

- To cut matching piece remove slotting cutter and add spacer supplied
- Matches older VJ paneling style

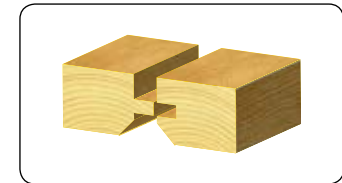
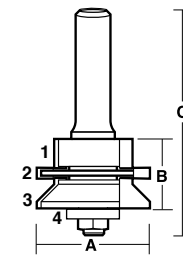

Product Group	Discount Group
R714	Z0904

Part No.	A		B		C		T Min		T Max		Shank		Barcode
	inch	mm	inch	mm	inch	mm	inch	mm	inch	mm	inch	mm	
TTG 10 1/2	1-5/8	41.3	1	25.4	3-1/8	79.4	15/32	12	13/16	20.6	1/2	12.7	9314350015913
TTGR 10	1-1/8	28.6	-	-	(1) Cutter only 10.5 mm		-	-	-	-	-	-	9314350015500
TTGS 10	1-5/8	41.3	-	-	(2) Slot cutter 4.0 mm		-	-	-	-	-	-	9314350015517
TTGC 10	1-5/8	41.3	-	-	(3) Bevel cutter 10.8 mm		-	-	-	-	-	-	9314350015494
TTGW 10	-	-	-	-	(4) Spacer		-	-	-	-	-	-	9314350015524

Replacement arbor TA19

2 Flute - Drawer Joint Bit - Carbide Tipped

- Wood thickness: Min: 10mm for X, Min 15mm for Y
- Very easy to use for quick joining
- Option to create a plain or rebated drawer by varying the depth of cut

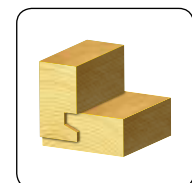
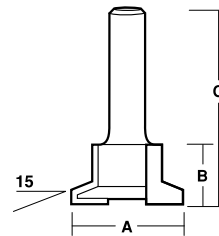

Product Group	Discount Group
R715	Z0904

Part No.	A		B		C		Shank		Barcode
	inch	mm	inch	mm	inch	mm	inch	mm	
TGD 35 1/2	1-3/8	35	0.768	19.5	2-1/2	63.5	1/2	12.7	9314350009332

2 Flute – Tongue & Groove Bit for Floor Boards with Ball Bearing Guide – Carbide Tipped

- Versatile joining cutter

Product Group R716 **Discount Group** Z0904

Part No.	A		B		C		Shank		Barcode
	inch	mm	inch	mm	inch	mm	inch	mm	
TAG 01 B 1/2	-	32.4	1-3/64	26.7	-	82.5	1/2	12.7	9314350020252
TAG 02 B 1/2	1-5/16	33.4	17/64	6.7	-	63.7	1/2	12.7	9314350020269
TAGC 01					-				9314350020276
TAGC 02					-				9314350020283

Replacement bearing TB19



TAG 01 B 1/2



TAG 02 B 1/2

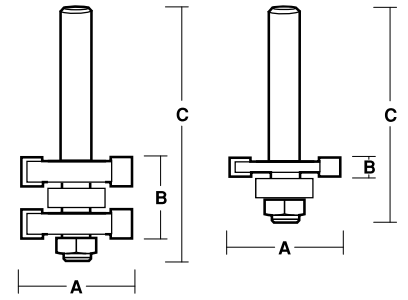

TAG 01 B 1/2

TAG 02 B 1/2

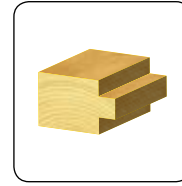

2 Flute – Mitre Lock Bit – Carbide Tipped

- For joining material at 90°, also can produce reasonably strong straight joints
- Only one bit is required
- For 90° joints, cut second piece of timber at 90°s to first piece to produce joint.
- For straight joints, invert the second piece of timber for matching joint

Product Group R717 **Discount Group** Z0904

Part No.	A		B		C		T Min		T Max		Shank		Barcode
	inch	mm	inch	mm	inch	mm	inch	mm	inch	mm	inch	mm	
TML 60 1/2	2-3/8	60.3	61/64	24.2	3	76	-	8.7	-	20	1/2	12.7	9314350007475

*Instructional sheet available upon request

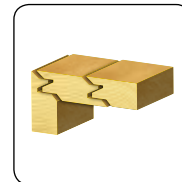
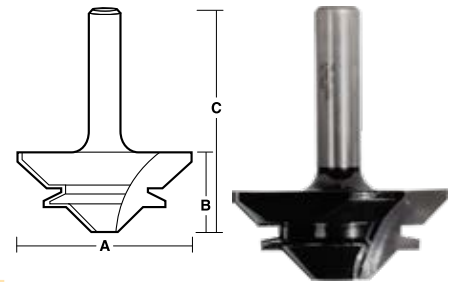

2 Flute – Joining Bit – Carbide Tipped

- Wood thickness: Min: 10mm, Max 45mm

Product Group R718 **Discount Group** Z0904

Part No.	A		B		C		T Min		T Max		Shank		Barcode
	inch	mm	inch	mm	inch	mm	inch	mm	inch	mm	inch	mm	
TGC 100 1/2	1-3/4	44.4	1-7/8	47	3-7/8	98	-	10	-	45	1/2	12.7	9314350007949

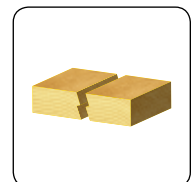
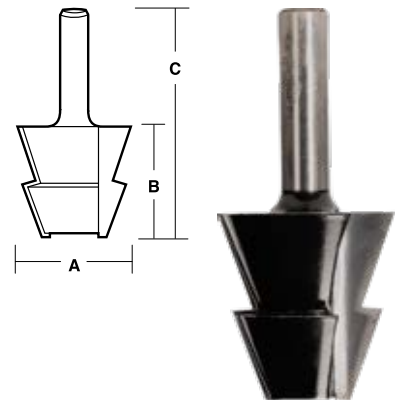

Wavy Joint Bit

- Increases joint strength by increasing glued surface area
- Also suitable for solid surface materials

Product Group **Discount Group**
R719 Z0904

Part No.	A		B		C		Shank		Barcode
	inch	mm	inch	mm	inch	mm	inch	mm	
TWJ161/2	5/8	16	2-1/64	51.3	4-1/32	102.3	1/2	12.7	9314350025837

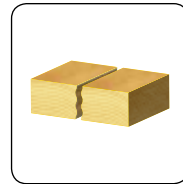
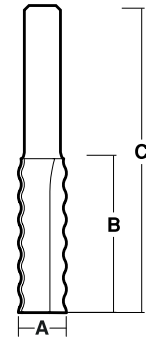

ROUTER BITS

PANEL DOOR BITS

2 Flute - Panel Door Bit - Carbide Tipped

- The TPD 1B-1/2 and TPD 2-1/2 are manufactured as matched sets in order that the rail and stile fit together as perfect joints
- The TPD 1B-1/2 now has a ball bearing guide ensuring simpler set ups for professional results
- Arches on your cupboard doors are now much easier to achieve
- Traditional panel door style & rail profile
- Wood thickness: Min 20mm, Max 25mm

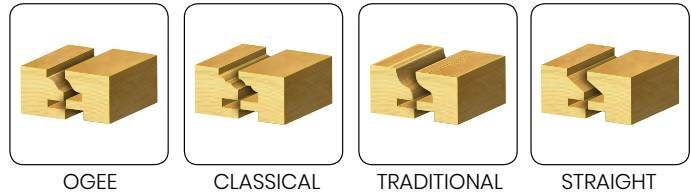

Product Group **Discount Group**
R720 Z0904

Part No.	A		B		C		Shank		Barcode
	inch	mm	inch	mm	inch	mm	inch	mm	
TPD1B1/2	-	55	-	29	-	94	1/2	12.7	9314350007499
TPD21/2	-	54	-	25	-	76	1/2	12.7	9314350007505

Part No.	Reversible	Stacked Stile and rail	Common Profile Cutter	Barcode
-				
TPDR10 B1/2	•			9314350007550
TPDS10 B1/2		•		9314350007901
TPDC10			•	9314350008656
-				
TPDR11 B1/2	•			9314350007833
TPDS11 B1/2		•		9314350007918
TPDC11			•	9314350008663
-				
TPDR12 B1/2	•			9314350007840
TPDS12 B1/2		•		9314350007925
TPDC12			•	9314350008670
-				
TPDR13 B1/2	•			9314350007857
TPDS13 B1/2		•		9314350007932
TPDC13			•	9314350008687

Replacement bearing TB17

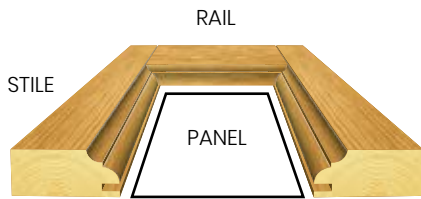

Perspective view of panel door (with one rail removed).

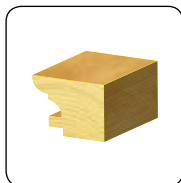
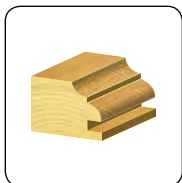
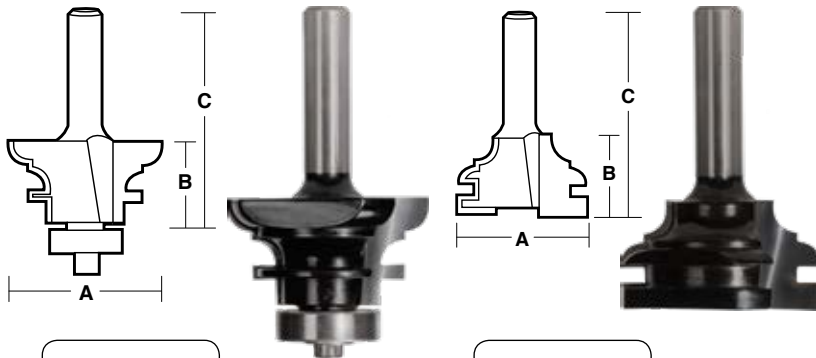

2 Flute – Panel Door Bit – Carbide Tipped

- Wood thickness: Min: 16mm Max 20mm
- The only panel door stile & rail bit available in 1/4" shank diameter (TPS 8 B-1 & TPS 8-2)

Product Group **Discount Group**
R724 Z0904

Part No.	A		B		C		R Radius		Shank		Barcode
	inch	mm	inch	mm	inch	mm	inch	mm	inch	mm	
TPS 8 B-1	1-3/8	35	17/32	13.5	2-1/2	63.5	8	-	1/4	6.35	9314350007512
TPS 8 B1/2-1	1-3/8	35	17/32	13.5	2-7/8	73	8	-	1/2	12.7	9314350007536
TPSG 8	1-3/8	35								Cutter only	9314350011847

Replacement bearing TB14

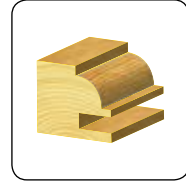
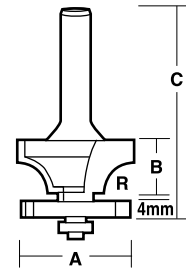

2 Flute – Panel Door Bit – Carbide Tipped

- Wood thickness: Min: 16mm Max 20mm
- The only panel door stile & rail bit available in 1/4" shank diameter (TPS 8 B-1 & TPS 8-2)

Product Group **Discount Group**
R725 Z0904

Part No.	A		B		C		R Radius		Shank		Barcode
	inch	mm	inch	mm	inch	mm	inch	mm	inch	mm	
TPS 8-2	1-3/8	35	7/8	22.2	2-1/4	57.1	8	-	1/4	6.35	9314350007529
TPS 81/2-2	1-3/8	35	7/8	22.2	2-5/8	67	8	-	1/2	12.7	9314350007543

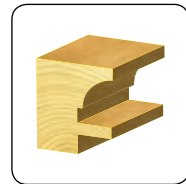
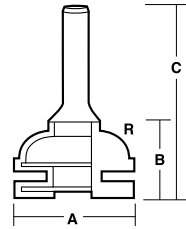

Window Sash & Rail Bit

- These two bits work together to produce a complete divided light sash
- The TCW 2B 1/2 is used to cope the rails, sash bars and muntins
- The TCW 1B 1/2 cuts the profile on all components
- Cuts all composition materials, plywood, hardwood and soft wood
- Use on table mounted portable routers

Product Group **Discount Group**
R726 Z0904

Part No.	A		B		C		R Radius		Shank		Barcode
	inch	mm	inch	mm	inch	mm	inch	mm	inch	mm	
TCW 1B 1/2	1.654	42	1-1/2	38.1	3.55	90.1	0.2	5.08	1/2	12.7	9314350011731
TCW 2B 1/2	1.654	42	0.609	15.5	2.77	70.5	0.2	5.08	1/2	12.7	9314350011748
TCW 3	1.654	42								Cutter only	9314350011755

Replacement bearing TB12

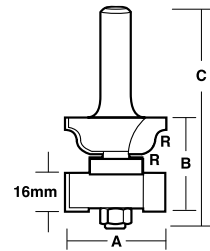

TCW 1B 1/2

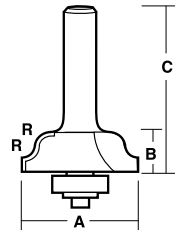

TAG 02 B 1/2

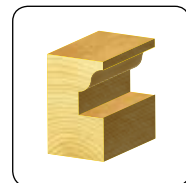
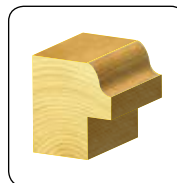

2 Flute - Raised Panel Bit - Carbide Tipped

- This bit produces an Ogee Fillet on panel doors and draw fronts

Product Group **Discount Group**
R727 Z0904

Part No.	A		B		C		Bearing No.	Shank		Barcode
	inch	mm	inch	mm	inch	mm		inch	mm	
TOG 57 B 1/2	2-1/4	57	41/64	16.3	3	76	TB11	1/2	12.7	9314350007604
TOG 67 B 1/2	2-1/4	57	41/64	16.3	3	76	TB9	1/2	12.7	9314350007611
WITHOUT BALL BEARING										
TOG 57 1/2	2-1/4	57	41/64	16.3	2-3/4	70	-	1/2	12.7	9314350008540

Replacement bearing TB14

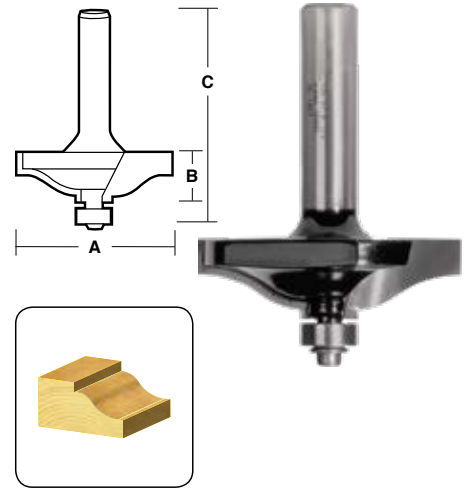

2 Flute - Elliptical Beading Bit Wide Flat Bottom - Carbide Tipped

- Specially designed for grooving panel doors

Product Group **Discount Group**
R728 Z0904

Part No.	A		B		C		R Radius		Shank		Barcode
	inch	mm	inch	mm	inch	mm	inch	mm	inch	mm	
TE 808 1/2	1-13/64	30.5	7/16	11	2-7/16	62	3/8	9.5	1/2	12.7	9314350012226
TE 812 1/2	1-1/4	31.8	9/16	14.2	2-9/16	65	3/8	9.5	1/2	12.7	9314350001497

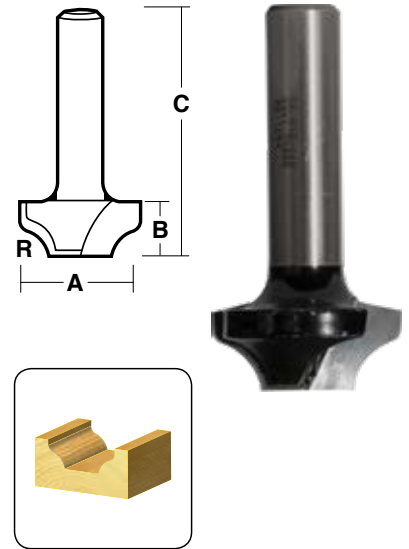

2 Flute - Panel Bit Wide Flat Bottom - Carbide Tipped

- Specially designed for grooving panel doors

Product Group **Discount Group**
R729 Z0904

Part No.	A1		A2		B		C		Shank	Bevel	Barcode
	inch	mm	inch	mm	inch	mm	inch	mm			
TPD 25	1	25.4	3/8	9.5	7/16	11	1-5/8	41	1/4	25°	9314350008410
TPD 25 1/2	1	25.4	3/8	9.5	7/16	11	2-1/8	54	1/2	25°	9314350008427
TPD 50	1.575	40	1/2	12.7	9/16	14.3	1-13/16	46	1/4	25°	9314350004962
TPD 50 1/2	1.575	40	1/2	12.7	9/16	14.3	2-5/16	58.5	1/2	25°	9314350004979

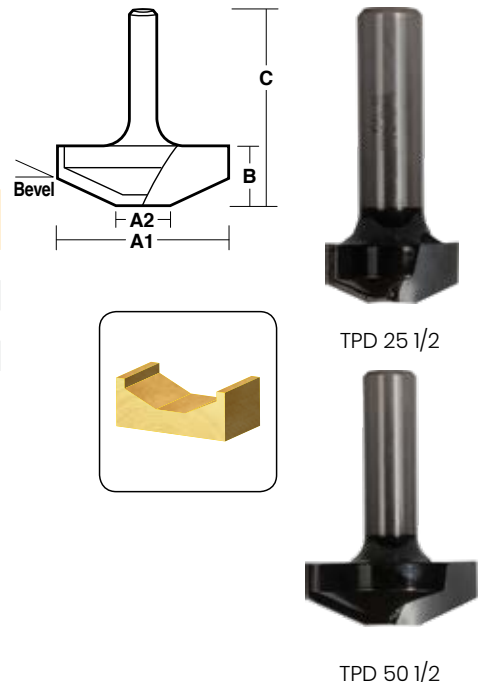

2 Flute – Raised Panel Bit with Ball Bearing Guide – Carbide Tipped

- This bit is used for panel doors and other decorative edges

Product Group **Discount Group**
R730 Z0904

Part No.	A1		A2		B		C		Bevel	Barcode
	inch	mm	inch	mm	inch	mm	inch	mm		
TRP 40 B 1/2	1-5/8	40	1/8	3.2	1/2	12.7	2-5/8	67	25°	9314350007628

Replacement bearing TB11

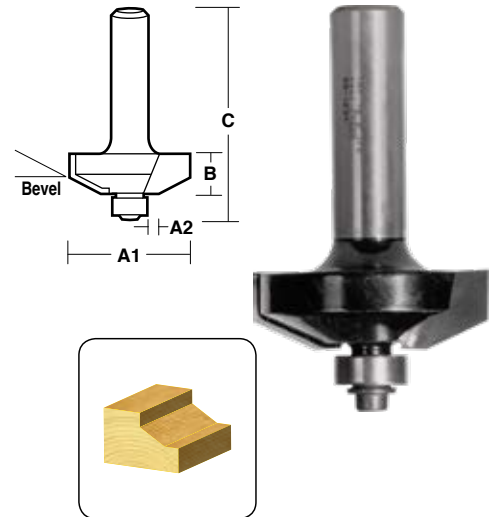

2 Flute – Raised Panel Bit – Carbide Tipped

- This bit is used for panel doors and other decorative edges
- Also available with a ball bearing guide.

Product Group **Discount Group**
R941 Z0904

Part No.	A		A1		B		C		Shank		Barcode
	inch	mm	inch	mm	inch	mm	inch	mm	inch	mm	
TPD 3 1/2	2.83	72	-	25.4	3/4	19	2-3/4	70	1/2	12.7	9314350007567
TPD 3 B 1/2	2.83	72	-	25.4	3/4	19	3	76	1/2	12.7	9314350007864

Replacement bearing TB11

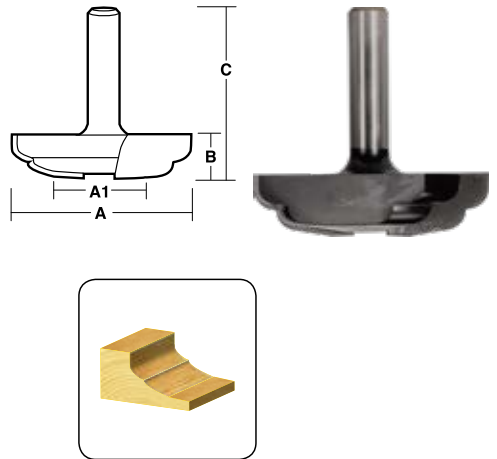

2 Flute – Raised Panel Bit – Carbide Tipped

- This bit is used for panel doors and other decorative edges
- Also available with a ball bearing guide.

Product Group **Discount Group**
R936 Z0904

Part No.	A		A1		B		C		Shank		Barcode
	inch	mm	inch	mm	inch	mm	inch	mm	inch	mm	
TPD 4 1/2	2-3/8	60.3	-	24.4	11/16	17.3	2-5/8	66.8	1/2	12.7	9314350007574
TPD 4 B 1/2	2-3/8	60.3	-	24.4	11/16	17.3	-	72.1	1/2	12.7	9314350007871

Replacement bearing TB11

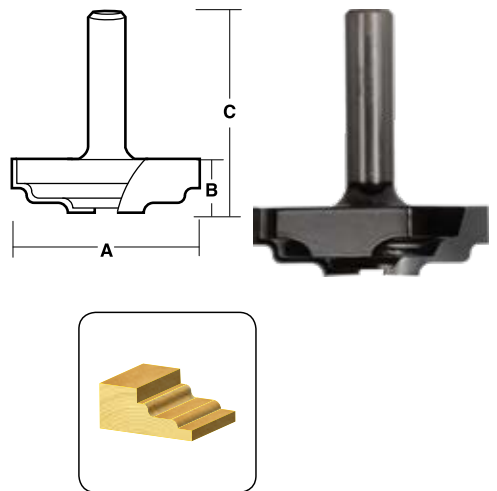

2 Flute - Raised Panel Bit - Carbide Tipped

- This bit is used for panel doors and other decorative edges
- Also available with a ball bearing guide.

Product Group **Discount Group**
R937 Z0904

Part No.	A		A1		B		C		Shank		Barcode
	inch	mm	inch	mm	inch	mm	inch	mm	inch	mm	
TPD 5 1/2	3	76.2	-	37.0	5/8	15.9	2-3/4	70	1/2	12.7	9314350007581
TPD 5 B 1/2	3	76.2	-	37.0	5/8	15.9	2-3/4	70	1/2	12.7	9314350007888

Replacement bearing TB11

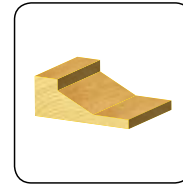
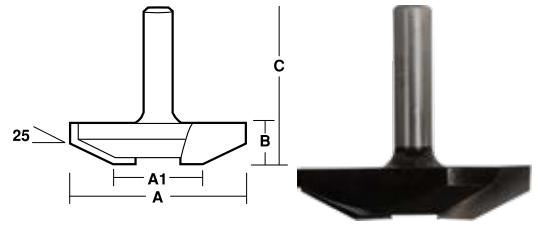

2 Flute - Raised Panel Bit - Carbide Tipped

- This bit is used for panel doors and other decorative edges
- Also available with a ball bearing guide.

Product Group **Discount Group**
R938 Z0904

Part No.	A		A1		B		C		Shank		Barcode
	inch	mm	inch	mm	inch	mm	inch	mm	inch	mm	
TPD 6 1/2	3	76	-	17.5	5/8	15.9	2-3/4	70	1/2	12.7	9314350007598
TPD 6 B 1/2	3	76	-	17.5	5/8	15.9	3	76	1/2	12.7	9314350007895

Replacement bearing TB11

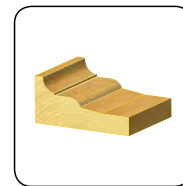
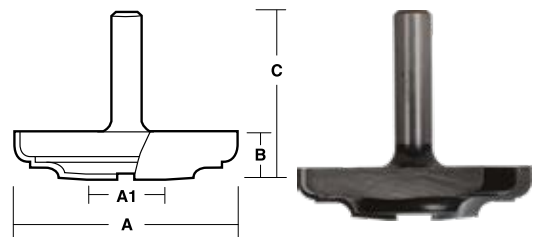

2 Flute - Vertical Raised Panel Bit - Carbide Tipped

- This bit is used for panel doors and other decorative edges

Product Group **Discount Group**
R731 Z0904

Part No.	A		B		C		Shank		Barcode
	inch	mm	inch	mm	inch	mm	inch	mm	
TPDV 3 1/2	1.36	34.5	1.7	43	3-5/8	92	1/2	12.7	9314350011809

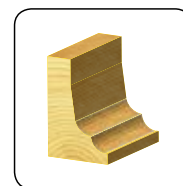
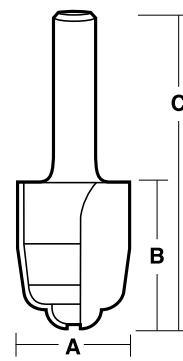

ROUTER BITS



2 Flute – Vertical Raised Panel Bit – Carbide Tipped

- This bit is used for panel doors and other decorative edges

Part No.	A		B		C		Shank		Barcode
	inch	mm	inch	mm	inch	mm	inch	mm	
TPDV 4 1/2	1-1/8	28.6	1-1/2	38.1	3-1/3	89	1/2	12.7	9314350011816

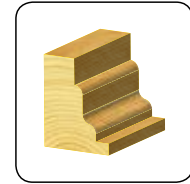
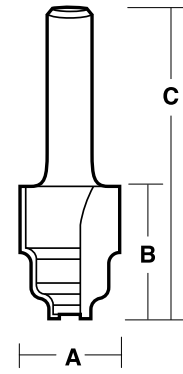

2 Flute – Vertical Raised Panel Bit – Carbide Tipped

- This bit is used for panel doors and other decorative edges

Part No.	A		B		C		Shank		Barcode
	inch	mm	inch	mm	inch	mm	inch	mm	
TPDV 5 1/2	1-1/4	31.8	1-1/2	38.1	3-1/3	89	1/2	12.7	9314350011823

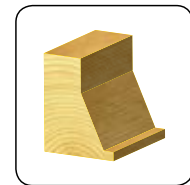
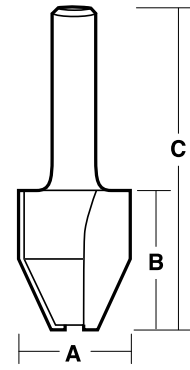

2 Flute – Vertical Raised Panel Bit – Carbide Tipped

- This bit is used for panel doors and other decorative edges

Part No.	A		B		C		Shank		Barcode
	inch	mm	inch	mm	inch	mm	inch	mm	
TPDV 6 1/2	1-1/8	28.6	2	50.8	3-7/8	98	1/2	12.7	9314350011830

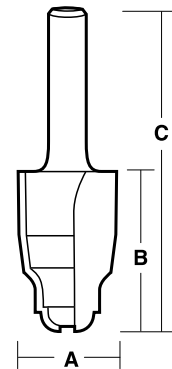

2 Flute - Assemblies - Carbide Tipped

• By using the guide on tour routing machine, the maximum depth of cut can be obtained

Product Group **Discount Group**
R734 Z0904

Part No.	A		B		D Max Depth	Arbor No.	Shank		Barcode
	inch	mm	inch	mm			inch	mm	
TA 500-1.6M	2	50.8	1/16	1.6	19	TA 15	1/4	6.35	9314350005181
TA 500-1.6M 1/2	2	50.8	1/16	1.6	19	TA 16	1/2	12.7	9314350005198
TA 500-2M	2	50.8	5/64	2	19	TA 15	1/4	6.35	9314350005389
TA 500-2M 1/2	2	50.8	5/64	2	19	TA 16	1/2	12.7	9314350005228
TA 500-2.5M	2	50.8	3/32	2.5	19	TA 15	1/4	6.35	9314350005402
TA 500-2.5M 1/2	2	50.8	3/32	2.5	19	TA 16	1/2	12.7	9314350005419
TA 500-2.8M	2	50.8	7/64	2.8	19	TA 15	1/4	6.35	9314350014831
TA 500-2.8M 1/2	2	50.8	7/64	2.8	19	TA 16	1/2	12.7	9314350014848
TA 500-3.2M	2	50.8	1/8	3.2	19	TA 15	1/4	6.35	9314350005242
TA 500-3.2M 1/2	2	50.8	1/8	3.2	19	TA 16	1/2	12.7	9314350005259
TA 500-3.6M	2	50.8	9/64	3.6	19	TA 15	1/4	6.35	9314350005266
TA 500-3.6M 1/2	2	50.8	9/64	3.6	19	TA 16	1/2	12.7	9314350005273
TA 500-4M	2	50.8	5/32	4	19	TA 15	1/4	6.35	9314350005471
TA 500-4M 1/2	2	50.8	5/32	4	19	TA 16	1/2	12.7	9314350005303
TA 500-4.8M	2	50.8	3/16	4.8	19	TA 15	1/4	6.35	9314350005495
TA 500-4.8M 1/2	2	50.8	3/16	4.8	19	TA 16	1/2	12.7	9314350005280
TA 500-5.5M	2	50.8	7/32	5.5	19	TA 15	1/4	6.35	9314350005327
TA 500-5.5M 1/2	2	50.8	7/32	5.5	19	TA 16	1/2	12.7	9314350005334
TA 500-6.4M	2	50.8	1/4	6.4	19	TA 15	1/4	6.35	9314350005341
TA 500-6.4M 1/2	2	50.8	1/4	6.4	19	TA 16	1/2	12.7	9314350005358
TA 500-8.0M	2	50.8	5/16	8	19	TA 17	1/4	6.35	9314350020306
TA 500-8.0M 1/2	2	50.8	5/16	8	19	TA18	1/2	12.7	9314350020313

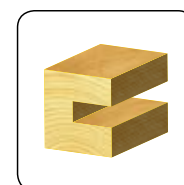
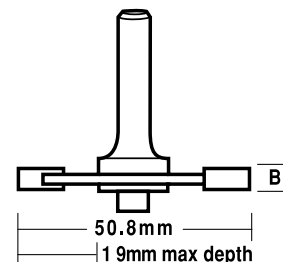

2 Flute - Slotting Cutter Only - Carbide Tipped

• Replacement and additional cutters can be purchased to fit an existing arbor

Product Group **Discount Group**
R732 Z0904

Part No.	A		B		Bore		Barcode
	inch	mm	inch	mm	inch	mm	
T 500-1.6M	2	50.8	1/16	1.6	5/16	8	9314350005099
T 500-2M	2	50.8	5/64	2	5/16	8	9314350005105
T 500-2.5M	2	50.8	3/32	2.5	5/16	8	9314350005112
T 500-2.8M	2	50.8	7/64	2.8	5/16	8	9314350014800
T 500-3.2M	2	50.8	1/8	3.2	5/16	8	9314350005129
T 500-3.6M	2	50.8	9/64	3.6	5/16	8	9314350005136
T 500-4M	2	50.8	5/32	4	5/16	8	9314350005143
T 500-4.8M	2	50.8	3/16	4.8	5/16	8	9314350005150
T 500-5.5M	2	50.8	7/32	5.5	5/16	8	9314350005167
T 500-6.4M	2	50.8	1/4	6.35	5/16	8	9314350005174
T 500-8.0M	2	50.8	5/16	8	5/16	8	9314350020290

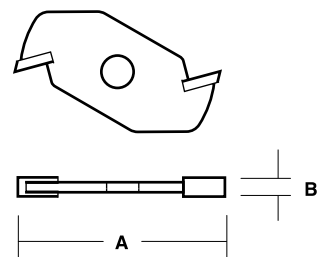

2 Flute – Assemblies with Ball Bearing Guide – Carbide Tipped

- Ball bearing guide eliminates time consuming set up of router machine guides

Product Group	Discount Group
R735	Z0904

Part No.	A		B		D Max Depth	Arbor No.	Shank		Barcode
	inch	mm	inch	mm			inch	mm	
TA 500-1.6MB	2	50.8	1/16	1.6	14.4	TA 4	1/4	6.35	9314350005365
TA 500-1.6MB1/2	2	50.8	1/16	1.6	14.4	TA 5	1/2	12.7	9314350005372
TA 500-2MB	2	50.8	5/64	2	14.4	TA 4	1/4	6.35	9314350005396
TA 500-2 MB 1/2	2	50.8	5/64	2	14.4	TA 5	1/2	12.7	9314350005235
TA 500-2.5MB	2	50.8	3/32	2.5	14.4	TA 4	1/4	6.35	9314350014817
TA 500-2.5MB1/2	2	50.8	3/32	2.5	14.4	TA 5	1/2	12.7	9314350014824
TA 500-2.8MB	2	50.8	7/64	2.8	14.4	TA 4	1/4	6.35	9314350005204
TA 500-2.8MB1/2	2	50.8	7/64	2.8	14.4	TA 5	1/2	12.7	9314350005211
TA 500-3.2MB	2	50.8	1/8	3.2	14.4	TA 4	1/4	6.35	9314350005426
TA 500-3.2MB1/2	2	50.8	1/8	3.2	14.4	TA 5	1/2	12.7	9314350005433
TA 500-3.6MB	2	50.8	9/64	3.6	14.4	TA 4	1/4	6.35	9314350005440
TA 500-3.6MB1/2	2	50.8	9/64	3.6	14.4	TA 5	1/2	12.7	9314350005457
TA 500-4 MB	2	50.8	5/32	4	14.4	TA 4	1/4	6.35	9314350005310
TA 500-4 MB 1/2	2	50.8	5/32	4	14.4	TA 5	1/2	12.7	9314350005488
TA 500-4.8MB	2	50.8	3/16	4.8	14.4	TA 4	1/4	6.35	9314350005297
TA 500-4.8MB1/2	2	50.8	3/16	4.8	14.4	TA 5	1/2	12.7	9314350005464
TA 500-5.5MB	2	50.8	7/32	5.5	14.4	TA 4	1/4	6.35	9314350005501
TA 500-5.5MB1/2	2	50.8	7/32	5.5	14.4	TA 5	1/2	12.7	9314350005518
TA 500-6.4MB	2	50.8	1/4	6.4	14.4	TA 4	1/4	6.35	9314350005525
TA 500-6.4MB1/2	2	50.8	1/4	6.4	14.4	TA 5	1/2	12.7	9314350005532
TA 500-8.0MB	2	50.8	5/16	8	14.4	TA 1	1/4	6.35	9314350020320
TA 500-8.0MB1/2	2	50.8	5/16	8	14.4	TA 3	1/2	12.7	9314350020337

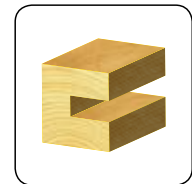
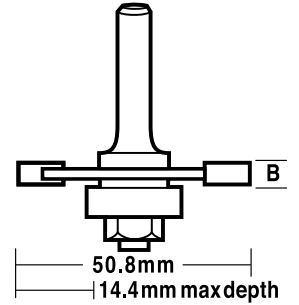

4 Flute – Assemblies with Ball Bearing Guide – Carbide Tipped

- Produce an accurate and professional job with minimal set up time
- TX Cutters: Max Depth: 29mm, Width: 80mm

Product Group	Discount Group
R737	Z0904

Part No.	A		B		D Max Depth	Arbor No.	Shank		Barcode
	inch	mm	inch	mm			inch	mm	
TA 700-1.6 MB	2	50.8	1/16	1.6	14.4	TA 4	1/4	6.35	9314350005815
TA 700-1.6MB1/2	2	50.8	1/16	1.6	14.4	TA 5	1/2	12.7	9314350005822
TA 700-2 MB	2	50.8	5/64	2	14.4	TA 4	1/4	6.35	9314350005839
TA 700-2 MB 1/2	2	50.8	5/64	2	14.4	TA 5	1/2	12.7	9314350005846
TA 700-2.5 MB	2	50.8	3/32	2.5	14.4	TA 4	1/4	6.35	9314350005853
TA 700-2.5MB1/2	2	50.8	3/32	2.5	14.4	TA 5	1/2	12.7	9314350005860
TA 700-2.8 MB	2	50.8	7/64	2.8	14.4	TA 4	1/4	6.35	9314350014879
TA 700-2.8MB1/2	2	50.8	7/64	2.8	14.4	TA 5	1/2	12.7	9314350014886
TA 700-3.2 MB	2	50.8	1/8	3.2	14.4	TA 4	1/4	6.35	9314350005877
TA 700-3.2MB1/2	2	50.8	1/8	3.2	14.4	TA 5	1/2	12.7	9314350005884
TA 700-3.6 MB	2	50.8	9/64	3.6	14.4	TA 4	1/4	6.35	9314350005891
TA 700-3.6MB1/2	2	50.8	9/64	3.6	14.4	TA 5	1/2	12.7	9314350005907
TA 700-4 MB	2	50.8	5/32	4	14.4	TA 4	1/4	6.35	9314350005914
TA 700-4 MB 1/2	2	50.8	5/32	4	14.4	TA 5	1/2	12.7	9314350005921
TA 700-4.8 MB	2	50.8	3/16	4.8	14.4	TA 4	1/4	6.35	9314350005761
TA 700-4.8MB1/2	2	50.8	3/16	4.8	14.4	TA 5	1/2	12.7	9314350005945
TXA700-4.8MB1/2	2	50.8	3/16	4.8	14.4	TA 7	1/2	12.7	9314350001626
TA 700-5.5 MB	2	50.8	7/32	5.5	14.4	TA 4	1/4	6.35	9314350005952
TA 700-5.5MB1/2	2	50.8	7/32	5.5	14.4	TA 5	1/2	12.7	9314350005969
TXA700-5.5MB1/2	2	50.8	7/32	5.5	14.4	TA 7	1/2	12.7	9314350001633
TA 700-6.4 MB	2	50.8	1/4	6.4	14.4	TA 4	1/4	6.35	9314350005976
TA 700-6.4MB1/2	2	50.8	1/4	6.4	14.4	TA 5	1/2	12.7	9314350005983
TXA700-6.4MB1/2	2	50.8	1/4	6.4	14.4	TA 7	1/2	12.7	9314350001640
TA 700-8.0 MB	2	50.8	5/16	8	14.4	TA 1	1/4	6.35	9314350020375
TA 700-8.0MB1/2	2	50.8	5/16	8	14.4	TA 3	1/2	12.7	9314350020382
TXA 700-8 MB1/2	2	50.8	5/16	8	14.4	TA 7	1/2	12.7	9314350001657

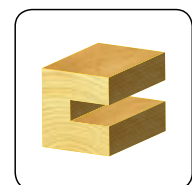
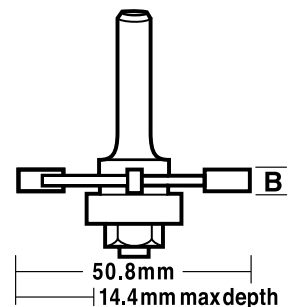

Replacement bearing TB12

4 Flute - Assemblies - Carbide Tipped

- Bits without bearings can be used where the bearing and nut interfere with the work piece configuration
- TX Cutters: Max Depth: 30mm, Width: 80mm

Product Group **Discount Group**
R736 Z0904

Part No.	A		B		D	Arbor No.	Shank		Barcode
	inch	mm	inch	mm			Max Depth	inch	
TA 700-1.6 M	2	50.8	1/16	1.6	19	TA 15	1/4	6.35	9314350005631
TA 700-1.6M1/2	2	50.8	1/16	1.6	19	TA 16	1/2	12.7	9314350005648
TA 700-2 M	2	50.8	5/64	2	19	TA 15	1/4	6.35	9314350005655
TA 700-2 M1/2	2	50.8	5/64	2	19	TA 16	1/2	12.7	9314350005662
TA 700-2.5 M	2	50.8	3/32	2.5	19	TA 15	1/4	6.35	9314350005679
TA 700-2.5M1/2	2	50.8	3/32	2.5	19	TA 16	1/2	12.7	9314350005686
TA 700-2.8 M	2	50.8	7/64	2.8	19	TA 15	1/4	6.35	9314350014855
TA 700-2.8 M1/2	2	50.8	7/64	2.8	19	TA 16	1/2	12.7	9314350014862
TA 700-3.2 M	2	50.8	1/8	3.2	19	TA 15	1/4	6.35	9314350005693
TA 700-3.2M1/2	2	50.8	1/8	3.2	19	TA 16	1/2	12.7	9314350005709
TA 700-3.6 M	2	50.8	9/64	3.6	19	TA 15	1/4	6.35	9314350005716
TA 700-3.6M1/2	2	50.8	9/64	3.6	19	TA 16	1/2	12.7	9314350005723
TA 700-4 M	2	50.8	5/32	4	19	TA 15	1/4	6.35	9314350005730
TA 700-4 M1/2	2	50.8	5/32	4	19	TA 16	1/2	12.7	9314350005747
TA 700-4.8 M	2	50.8	3/16	4.8	19	TA 15	1/4	6.35	9314350005754
TA 700-4.8M1/2	2	50.8	3/16	4.8	19	TA 16	1/2	12.7	9314350005938
TXA 700-4.8M1/2	2	50.8	3/16	4.8	19	TA 8	1/2	12.7	9314350001589
TA 700-5.5 M	2	50.8	7/32	5.5	19	TA 15	1/4	6.35	9314350005778
TXA 700-5.5M1/2	2	50.8	7/32	5.5	19	TA 16	1/2	12.7	9314350001596
TA 700-6.4 M	2	50.8	1/4	6.4	19	TA 15	1/4	6.35	9314350005792
TA 700-6.4M1/2	2	50.8	1/4	6.4	19	TA 16	1/2	12.7	9314350005808
TXA 700-6.4M1/2	2	50.8	1/4	6.4	19	TA 8	1/2	12.7	9314350001602
TA 700-8.0 M	2	50.8	5/16	8	19	TA 17	1/4	6.35	93143500020351
TA 700-8.0M1/2	2	50.8	5/16	8	19	TA 18	1/2	12.7	93143500020368
TXA 700-8 M1/2	2	50.8	5/16	8	19	TA 8	1/2	12.7	9314350001619

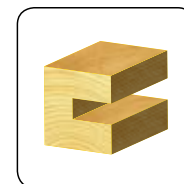
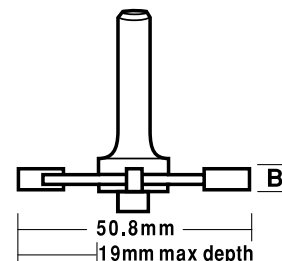

4 Flute - Slotting Cutter Only - Carbide Tipped

- For extra smooth cutting and finishes with longer tool life between sharpening

Product Group **Discount Group**
R733 Z0904

Part No.	A		B		Bore		Barcode
	inch	mm	inch	mm	inch	mm	
T 700-1.6 M	2	50.8	1/16	1.6	5/16	8	9314350005549
T 700-2 M	2	50.8	5/64	2	5/16	8	9314350005556
T 700-2.5 M	2	50.8	3/32	2.5	5/16	8	9314350005563
T 700-2.8 M	2	50.8	7/64	2.8	5/16	8	9314350014657
T 700-3.2 M	2	50.8	1/8	3.2	5/16	8	9314350005570
T 700-3.6 M	2	50.8	9/64	3.6	5/16	8	9314350005587
T 700-4 M	2	50.8	5/32	4	5/16	8	9314350005594
T 700-4.8 M	2	50.8	3/16	4.8	5/16	8	9314350005600
T 700-5.5 M	2	50.8	7/32	5.5	5/16	8	9314350005617
T 700-6.4 M	2	50.8	1/4	6.35	5/16	8	9314350005624
T 700-8.0 M	2	50.8	5/16	8	5/16	8	93143500020344
TX 700-4.8 M	3-5/32	80	3/16	4.8	1/2	12.7	9314350001541
TX 700-5.5 M	3-5/32	80	7/32	5.5	1/2	12.7	9314350001558
TX 700-6.4 M	3-5/32	80	1/4	6.35	1/2	12.7	9314350001565
TX 700-8 M	3-5/32	80	5/16	8	1/2	12.7	9314350001572

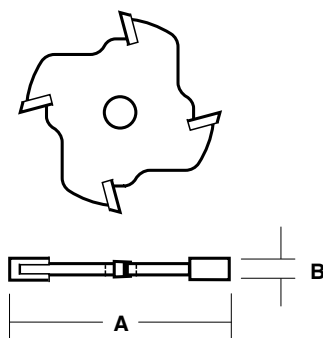

Laminate Trim Set – 3 Pieces

- Carbide Tipped

Product Group	Discount Group
R533	Z0904

Part No.	Description	Page No.	Barcode
TRBS 1	3 Pieces		9314350002463
T 192.22 B	2 Flute – Ball Bearing Guide Carbide Tipped	29	
T 192.00 B	2 Flute – Ball Bearing Guide Carbide Tipped	29	
T 208 S	Single Flute – Straight Solid Carbide	16	

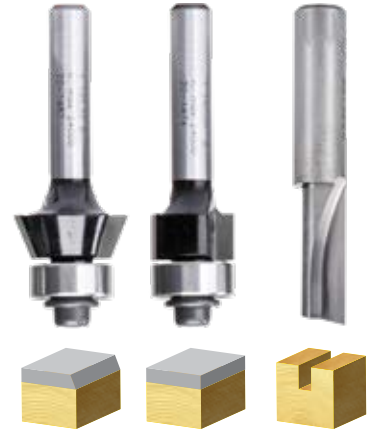

Router Kits + Bonus Storage Box – 5 Pieces

- Sturdy handled plastic carry case, holds up to 21 x 1/4" and 12 x 1/2" shank bits

Product Group	Discount Group
R738	Z0904

Part No.	Description 1/4" Shank	Page No.	Barcode
TRBS 20 1/4	5 Pieces		9314350016019
T 219 M	19mm Straight	17	
TS 8016 B	1/2" Flush Trim	26	
T 508 B	1/4" Rounding Over	52	
T 1712 B	3/8" Rebate	62	
T 916 B	45° Chamfer	60	

Product Group	Discount Group
R738	Z0904

Part No.	Description 1/2" Shank	Page No.	Barcode
TRBS 30 1/2	5 Pieces		9314350016026
T 1413 M	13mm Straight	18	
T 8016 B 1/2	1/2" Flush Trim	26	
T 512 B 1/2	3/8" Rounding Over	52	
T 1712 B 1/2	3/8" Rebate	62	
T 916 B 1/2	45° Chamfer	60	



TRBS 20 1/4



TRBS 30 1/2

TRBS 500 – Case Only



ECONOCUT ROUTER BITS

- 101** BEADING BIT
- 103** BUDGET KIT
- 102** CHAMFERING BIT 45°
- 101** CLASSICAL BIT
- 100** CORE BOX BIT
- 101** COVE BIT
- 98** DOVETAIL BIT
- 100** FLUSH TRIM BIT
- 103** GREENLINE KIT
- 99** OGEE BIT
- 102** REBATING BIT
- 99** ROMAN OGEE BIT
- 100** ROUNDING OVER BIT
- 98** STRAIGHT BIT
- 99** VEE GROOVE BIT

Straight Bit

• For the Handyman/DIY user

Product Group **Discount Group**
R900 Z0905

Part No.	A	B	C	Shank		Barcode
	mm	mm	mm	inch	mm	
1/4" SHANK						
EY 206 M	6	16	46.7	1/4	6.35	9314350013001
EY 208 M	8	20	51.7	1/4	6.35	9314350013100
EY 210 M	10	20	51.7	1/4	6.35	9314350013117
EY 212 M	12	20	51.7	1/4	6.35	9314350013315
EY 213 M	13	20	51.7	1/4	6.35	9314350013018
EY 216 M	16	20	51.7	1/4	6.35	9314350013025
EY 218 M	18	20	51.7	1/4	6.35	9314350013322
EY 219 M	19	20	51.7	1/4	6.35	9314350013124

Product Group **Discount Group**
R901 Z0905

Part No.	A	B	C	Shank		Barcode
	mm	mm	mm	inch	mm	
1/2" SHANK						
EY 1406 M	6	16	61.9	1/2	12.7	9314350013414
EY 1408 M	8	20	63.5	1/2	12.7	9314350013506
EY 1410 M	10	25.4	66.7	1/2	12.7	9314350013513
EY 1412 M	12	25.4	66.7	1/2	12.7	9314350013629
EY 1413 M	13	25.4	66.7	1/2	12.7	9314350013186
EY 1416 M	16	25.4	66.7	1/2	12.7	9314350013193
EY 1418 M	18	25.4	66.7	1/2	12.7	9314350013636
EY 1419 M	19	25.4	66.7	1/2	12.7	9314350013216

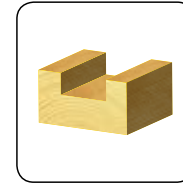
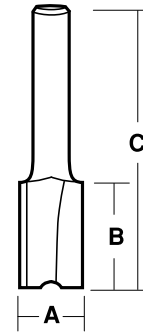

Dovetail Bit

• For the Handyman/DIY user

Product Group **Discount Group**
R902 Z0905

Part No.	A	B	C	Shank		Bevel	Barcode
	mm	mm	mm	inch	mm		
EY 1018	14.3	12.7	45	1/4	6.35	14.3	9314350013247
EY 1018 1/2	14.3	12.7	66.7	1/2	12.7	14.3	9314350013421

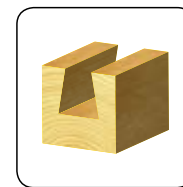
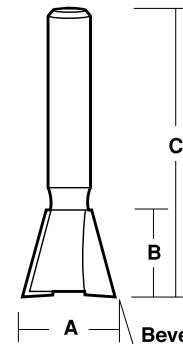

Vee Groove Bit

- For the Handyman/DIY user

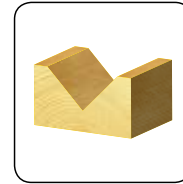
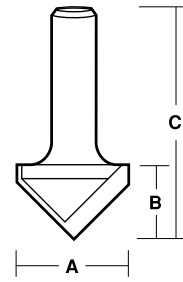

Product Group	Discount Group
R903	Z0905

Part No.	A		C	Shank		Barcode
	mm	mm		inch	mm	
EY 112	12.7	12.7	45	1/4	6.35	9314350013032
EY 112 1/2	12.7	12.7	54	1/2	12.7	9314350013438

Roman Ogee Bit

- For the Handyman/DIY user

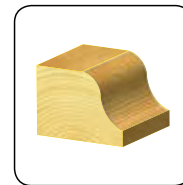
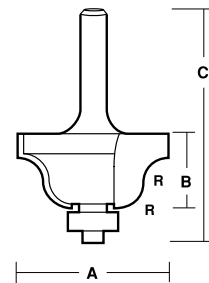

Product Group	Discount Group
R939	Z0905

Part No.	A		C	Shank		Radius	Barcode
	mm	mm		inch	mm		
EY 5705 B	25.5	13	52	1/4	6.35	4	9314350013094
EY 5705 B 1/2	25.5	13	66.7	1/2	12.7	4	9314350013490
EY 5708 B	34.9	19	60.3	1/4	6.35	6.35	9314350013292
EY 5708 B 1/2	34.9	19	70	1/2	12.7	6.35	9314350013605

Replacement bearing
 1/4" Shank = EYB 3
 1/2" Shank = EYB 4

Ogee Bit

- For the Handyman/DIY user

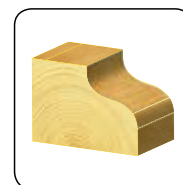
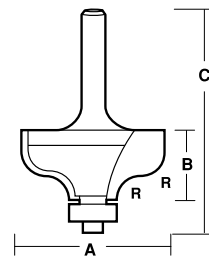

Product Group	Discount Group
R904	Z0905

Part No.	A		C	Shank		Radius	Barcode
	mm	mm		inch	mm		
EY 7506 B	36.3	16.5	57.1	1/4	6.35	4.8	9314350013155
EY 7506 B 1/2	36.3	16.5	66.7	1/2	12.7	4.8	9314350013544
EY 7508 B	41	19	57.1	1/4	6.35	6.35	9314350013353
EY 7508 B 1/2	41	19	70	1/2	12.7	6.35	9314350013667

Replacement bearing EYB 4

Flush Trim Bit

- For the Handyman/DIY user

Product Group	Discount Group
R905	Z0905

Part No.	A	B	C	Shank		Bearing	Barcode
	mm	mm	mm	inch	mm		
EY 8012 B	9.5	12.7	54	1/4	6.35	EY B3	9314350013148
EY 8012 B 1/2	9.5	25.4	74.6	1/2	12.7	EY B3	9314350013537
EY 8016 B	12.7	13	56	1/4	6.35	EY B4	9314350013230
EY 8016 B 1/2	12.7	25.4	79	1/2	12.7	EY B4	9314350013209
EY 8020 B	15.8	25.4	67	1/4	6.35	EY B1	9314350013308
EY 8020 B 1/2	15.8	25.4	79	1/2	12.7	EY B1	9314350013612

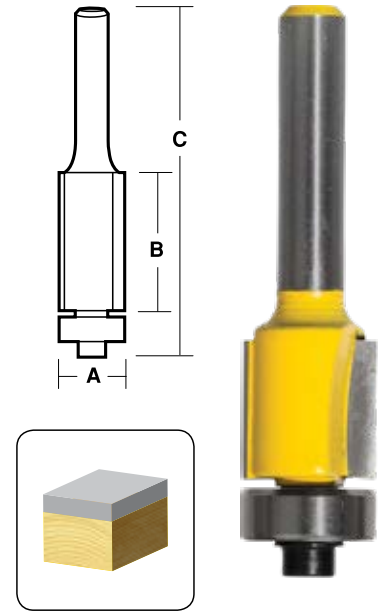

Rounding Over Bit

- For the Handyman/DIY user

Product Group	Discount Group
R906	Z0905

Part No.	A	B	C	Shank		Radius	Barcode
	mm	mm	mm	inch	mm	mm	
EY 508 B	25.4	13.5	52	1/4	6.35	6.35	9314350013056
EY 508 B 1/2	25.4	13.5	63.5	1/2	12.7	6.35	9314350013452
EY 510 B	28.5	15.5	56	1/4	6.35	7.9	9314350013261
EY 510 B 1/2	28.5	15.5	66.7	1/2	12.7	7.9	9314350013568
EY 512 B	31.8	16.5	56	1/4	6.35	9.5	9314350013063
EY 512 B 1/2	31.8	16.5	66.7	1/2	12.7	9.5	9314350013469
EY 516 B	38.1	19	60.3	1/4	6.35	12.7	9314350013377
EY 516 B 1/2	38.1	19	70	1/2	12.7	12.7	9314350013223

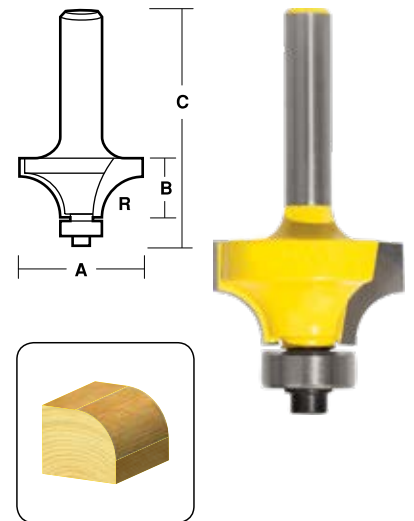

Replacement bearing EYB 4

Core Box Bit

- For the Handyman/DIY user

Product Group	Discount Group
R907	Z0905

Part No.	A	B	C	Shank		Barcode
	mm	mm	mm	inch	mm	
EY 416	12.7	9.5	40	1/4	6.35	9314350013049
EY 416 1/2	12.7	9.5	54	1/2	12.7	9314350013445
EY 420	15.8	12.7	45	1/4	6.35	9314350013254
EY 420 1/2	15.8	12.7	54	1/2	12.7	9314350013551
EY 424	19	12.7	47	1/4	6.35	9314350013360
EY 424 1/2	19	12.7	57.1	1/2	12.7	9314350013674

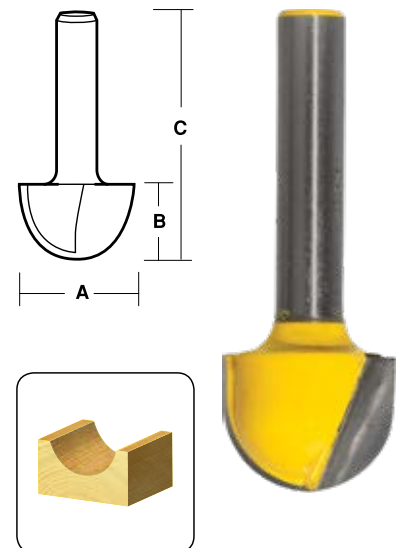

Beading Bit

- For the Handyman/DIY user

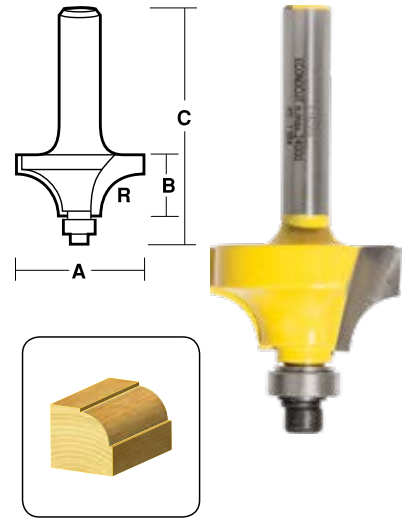

Part No.	Product Group		Discount Group				
	A	B	C	Shank	Radius	Barcode	
	mm	mm	mm	inch	mm		
Product Group	R908		Z0905				
EY 608 B	25.4	13.5	52	1/4	6.35	6.35	9314350013278
EY 608 B 1/2	25.4	13.5	63.5	1/2	12.7	6.35	9314350013757
EY 610 B	28.5	15.5	56	1/4	6.35	7.9	9314350013179
EY 610 B 1/2	28.5	15.5	66.7	1/2	12.7	7.9	9314350013681
EY 612 B	31.8	16.5	56	1/4	6.35	9.5	9314350013384
EY 612 B 1/2	31.8	16.5	66.7	1/2	12.7	9.5	9314350013698
EY 616 B	38.1	19	60.3	1/4	6.35	12.7	9314350013285
EY 616 B 1/2	38.1	19	70	1/2	12.7	12.7	9314350013582

Replacement bearing EYB 2

Cove Bit

- For the Handyman/DIY user

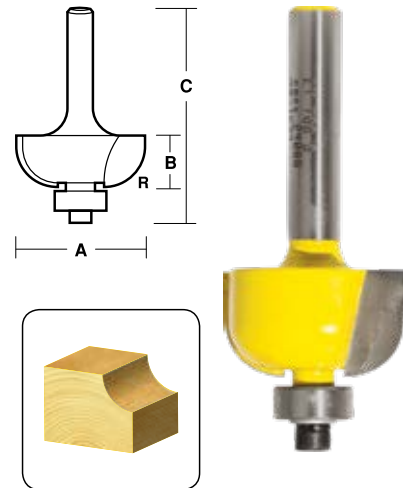

Part No.	Product Group		Discount Group				
	A	B	C	Shank	Radius	Barcode	
	mm	mm	mm	inch	mm		
Product Group	R909		Z0905				
EY 708 B	22	13	52	1/4	6.35	6.35	9314350013407
EY 708 B 1/2	25.4	13	63.5	1/2	12.7	6.35	9314350013711
EY 712 B	28.5	12.7	53	1/4	6.35	9.5	9314350013070
EY 712 B 1/2	31.8	12.7	66.7	1/2	12.7	9.5	9314350013476
EY 716 B	34.9	15.9	57.1	1/4	6.35	12.7	9314350013339
EY 716 B 1/2	34.9	15.9	70	1/2	12.7	12.7	9314350013643

Replacement bearing
 1/4" Shank = EYB 3
 1/2" Shank = EYB 4

Classical Bit

- For the Handyman/DIY user

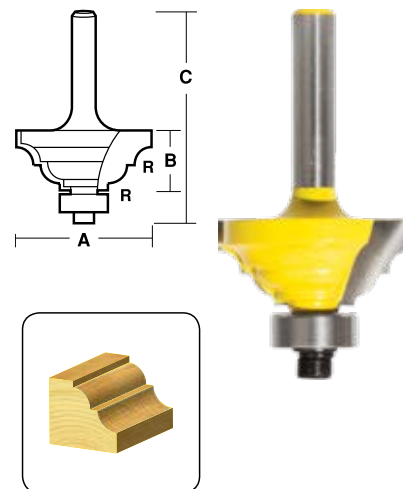

Part No.	Product Group		Discount Group				
	A	B	C	Shank	Radius	Barcode	
	mm	mm	mm	inch	mm		
Product Group	R910		Z0905				
EYC 8 B	28.5	12.7	50.8	1/4	6.35	3.2	9314350013162
EYC 8 B 1/2	35	15.9	57.1	1/4	6.35	4.8	9314350013599
EYC 12 B	28.5	12.7	63.5	1/2	12.7	3.2	9314350013391
EYC 12 B 1/2	35	15.9	70	1/2	12.7	4.8	9314350013704

Replacement bearing EYB 4

Rebating Bit

- For the Handyman/DIY user

Product Group **Discount Group**
R911 Z0905

Part No.	A	B	C	D	Shank		Barcode
	mm	mm	mm	mm	inch	mm	
EY 1708 B	22.2	12.7	53.8	6.35	1/4	6.35	9314350013346
EY 1708 B 1/2	28.5	12.7	53.8	9.5	1/4	6.35	9314350013650
EY 1712 B	25.4	12.7	63.5	6.35	1/2	12.7	9314350013131
EY 1712 B 1/2	31.8	12.7	63.5	9.5	1/2	12.7	9314350013520

Replacement bearing
1/4" Shank = EYB 3
1/2" Shank = EYB 4

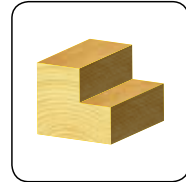
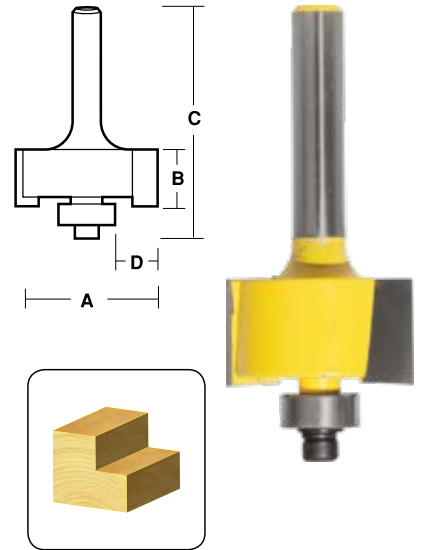

Chamfering Bit 45°

- For the Handyman/DIY user

Product Group **Discount Group**
R912 Z0905

Part No.	A	B	C	Shank		Barcode
	mm	mm	mm	inch	mm	
EY 916 B	32	15	55	1/4	6.35	9314350013087
EY 916 B 1/2	32	15	66.7	1/2	12.7	9314350013483

Replacement bearing EYB 3

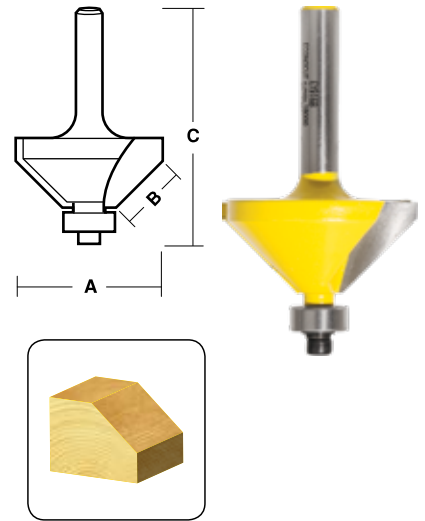

Budget Kit

- For the Handyman/DIY user
- Anti Kickback Design

Product Group	Discount Group
R914	Z0904

Part No.	Description	Barcode
TBUD-12	1/4" Shank - 12 Pieces - Wood Box	9314657078024

- 3 x Straight Bits (6, 12, 16mm)
- 1 x 1/2" Core Box Bit
- 1 x 1/2" V Groove Bit
- 1 x Dovetail Bit
- 1 x 1/2" Flush Trim Bit with bearing
- 1 x 1/4" Cove Bit with bearing
- 1 x 1/4" Rounding Over Bit with bearing
- 1 x 3/8" Rounding Over Bit with bearing
- 1 x 4mm Roman Ogee Bit with bearing
- 1 x 45° Chamfer Bit with bearing



Greenline Kit

- For the Handyman/DIY user
- Anti Kickback Design

Product Group	Discount Group
R915	Z0904

Part No.	Description	Barcode
TKIT-12	1/4" Shank - 12 Pieces - Plastic Clamshell	9314657078000
TKIT-12-1/2	1/2" Shank - 12 Pieces - Plastic Clamshell	9314657078017

- 3 x Straight Bits (1/4", 1/2", 3/4")
- 1 x 1/2" Core Box Bit
- 1 x 1/2" V Groove Bit
- 1 x Dovetail Bit
- 1 x 1/2" Flush Trim Bit with bearing
- 1 x 1/2" Cove Bit with bearing
- 1 x 3/8" Rebating with bearing
- 1 x 1/2" Rounding Over Bit with bearing
- 1 x 1/4" Roman Ogee Bit with bearing
- 1 x 45° Chamfer Bit with bearing





REPLACEABLE INSERT BITS

- 109** 2 FLUTE - BEVEL TRIMMING BIT - 22°
- 109** 2 FLUTE - BEVEL TRIMMING BIT - 45°
- 107** 2 FLUTE - FLUSH TRIMMING BIT - DOUBLE BEARING
- 106** 2 FLUTE - FLUSH TRIMMING BIT - ONE BEARING
- 108** 2 FLUTE - INVERTED FLUSH TRIMMING BIT
- 106** 2 FLUTE - STRAIGHT BIT
- 110** 3 FLUTE - SURFACE PLANER
- 110** 4 FLUTE - SURFACE PLANER
- 113** INDEXABLE INSERTS
- 111** MULTI SHAPE PROFILE BIT
- 111** MULTI SHAPE PROFILE BIT (WITHOUT INSERTS)
- 114** REPLACEMENT PARTS
- 108** SINGLE FLUTE - STRAIGHT BIT
- 109** SINGLE FLUTE - VEE GROOVE BIT - 90°
- 109** SINGLE FLUTE - VEE GROOVE BIT - 91°

2 Flute - Straight Bit

- Use end cutting inserts for rebating and grooving
- Supplied with end cutting inserts when new

Product Group	Discount Group
R783	Z0920

Part No.	D mm	B mm	L mm	d mm	Insert No.	Barcode
R1912	19	12	48	6.35	PL 12 12 1.5	9314350013780
R1912 1/2	19	12	58	12.7	PL 12 12 1.5	9314350013797

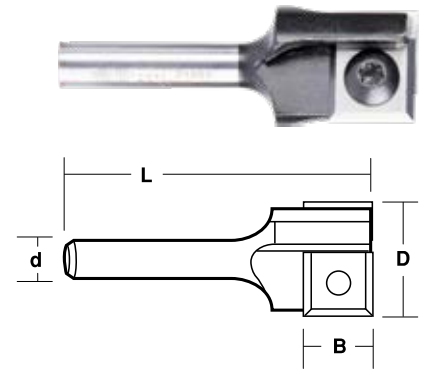

2 Flute - Straight Bit

- Use end cutting inserts for rebating and grooving
- Supplied with end cutting inserts when new

Product Group	Discount Group
R745	Z0920

Part No.	D mm	B mm	L mm	d mm	Insert No.	Barcode
R1830 1/2	18	30	75	12.7	PL 29.5 12 1.5 EC	9314350014381
R1830 16	18	30	75	16	PL 29.5 12 1.5 EC	9314350014398
R1840 1/2	18	40	80	12.7	PL 39.5 12 1.5 EC	9314350013803
R1930 1/2	19	30	75	12.7	PL 29.5 12 1.5 EC	9314350014404
R1930 16	19	30	75	16	PL 29.5 12 1.5 EC	9314350014411
R1940 1/2	19	40	84	12.7	PL 39.5 12 1.5 EC	9314350013810
R2030 1/2	20	30	85	12.7	PL 29.5 12 1.5 EC	9314350014428
R2030 16	20	30	85	16	PL 29.5 12 1.5 EC	9314350014436
R2040 1/2	20	40	85	12.7	PL 39.5 12 1.5 EC	9314350013827
R2040 16	20	40	85	16	PL 39.5 12 1.5 EC	9314350013834

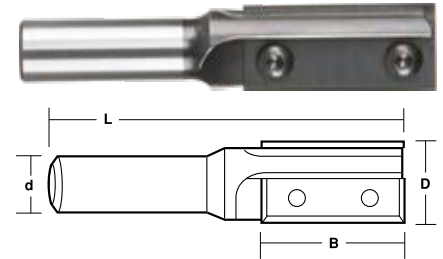

2 Flute - Straight Bit

- Use end cutting inserts for rebating and grooving
- Supplied with end cutting inserts when new
- 3 hole inserts used for greater support

Product Group	Discount Group
R746	Z0920

Part No.	D mm	B mm	L mm	d mm	Insert No.	Barcode
R1850 1/2-3	18	50	94	12.7	PL 50 12 1.7 EC	9314350019645
R1950 1/2-3	19	50	94	12.7	PL 50 12 1.7 EC	9314350019744
R1950 16-3	19	50	94	16	PL 50 12 1.7 EC	9314350019690

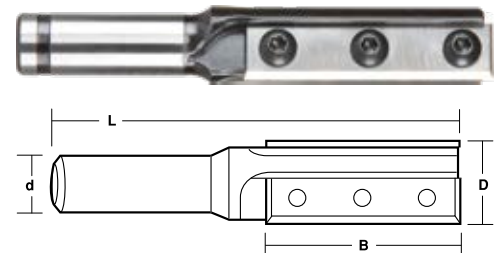

2 Flute - Flush Trimming Bit - One Bearing

Product Group	Discount Group
R747	Z0920

Part No.	D mm	B mm	L mm	d mm	Insert No.	Barcode
R1912 B	19	12	57	6.35	PL 12 12 1.5	9314350013841
R1912 B 1/2	19	12	65	12.7	PL 12 12 1.5	9314350013858

Replacement bearing TB5

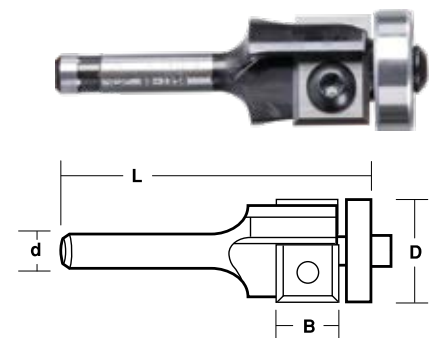

IMPORTANT: When locating inserts, hold inserts firmly into pocket when tightening screws.

NOTE: Part No's include cutter bodies complete with Inserts, Screws and Torx Key. Bearing if applicable. End Cutting Inserts, have End Cutting Clearance.

2 Flute - Flush Trimming Bit - Double Bearing

- Double bearing
- Replacement bearing TB5

Product Group R748 **Discount Group** Z0920

Part No.	D mm	B mm	L mm	d mm	Insert No.	Barcode
R1912 BB	19	12	61	6.35	PL 12 12 1.5	9314350014473
R1912 BB 1/2	19	12	69	12.7	PL 12 12 1.5	9314350014480

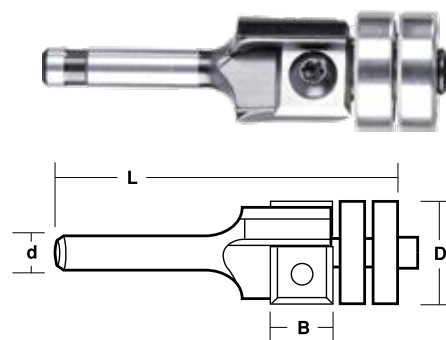

2 Flute - Flush Trimming Bit - One Bearing

- One bearing
- Replacement bearing TB5

Product Group R749 **Discount Group** Z0920

Part No.	D mm	B mm	L mm	d mm	Insert No.	Barcode
R1930 B 1/2	19	30	82	12.7	PL 30 12 1.5	9314350013865
R1940 B 1/2	19	40	93	12.7	PL 40 12 1.5	9314350014497

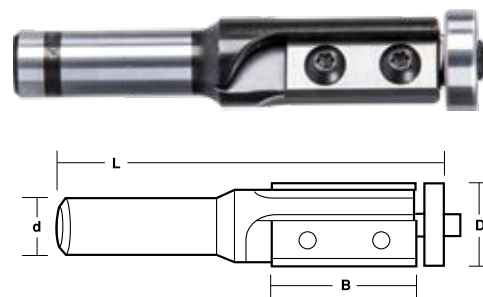

2 Flute - Flush Trimming Bit - Double Bearing

- Double bearing
- Replacement bearing TB5

Product Group R750 **Discount Group** Z0920

Part No.	D mm	B mm	L mm	d mm	Insert No.	Barcode
R1930 BB 1/2	19	30	93	12.7	PL 30 12 1.5	9314350014503
R1940 BB 1/2	19	40	105	12.7	PL 40 12 1.5	9314350014367

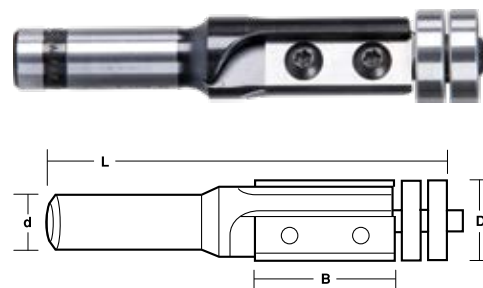

2 Flute - Flush Trimming Bit - One Bearing

- One bearing
- 3 hole inserts used for greater support
- Replacement bearing TB5

Product Group R751 **Discount Group** Z0920

Part No.	D mm	B mm	L mm	d mm	Insert No.	Barcode
R1950 B 1/2 - 3	19	50	100	12.7	PL 50 12 1.7 E/C	9314350014510

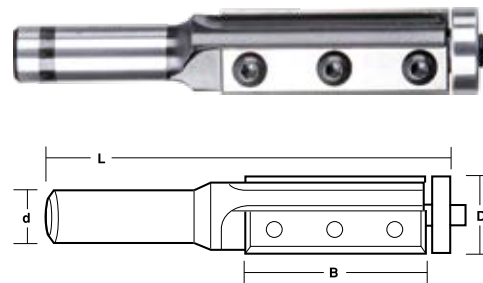

IMPORTANT: When locating inserts, hold inserts firmly into pocket when tightening screws.

NOTE: Part No's include cutter bodies complete with Inserts, Screws and Torx Key. Bearing if applicable. End Cutting Inserts, have End Cutting Clearance.

2 Flute - Inverted Flush Trimming Bit

- Supplied with end cutting inserts when new
- Retaining ring TZR 3

Product Group	Discount Group
R752	Z0920

Part No.	D mm	B mm	L mm	d mm	Insert No.	Replace. Bearings	Barcode
RV 1930 B 1/2	19.05	30	78	12.7	PL 29.5 12 1.5 EC	TB-4	9314350017863
RV 1940 B 1/2	19.05	40	88	12.7	PL 39.5 12 1.5 EC	TB-4	9314350014619
RV 2440 B 1/2	24	40	88	12.7	PL 39.5 12 1.5 EC	TB-20	9314350016033
RV 2830 B 1/2	28.6	30	78	12.7	PL 29.5 12 1.5 EC	TB-18	9314350017900
RV 2840 B 1/2	28.6	40	88	12.7	PL 39.5 12 1.5 EC	TB-18	9314350017917
RV 2850 B 1/2 - 2	28.6	50	98	12.7	PL 49.5 12 1.5 EC	TB-18	9314350025035

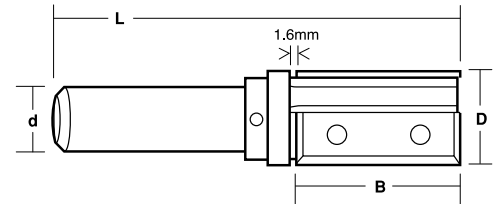

2 Flute - Inverted Flush Trimming Bit

- Retaining ring TZR 3

Product Group	Discount Group
R753	Z0920

Part No.	D mm	B mm	L mm	d mm	Insert No.	Replace. Bearings	Barcode
RV 1950 B 1/2 - 3	19.05	50	98	12.7	PL 50 12 1.7 EC	TB-4	9314350017887
RV 2450 B 1/2 - 3	24	50	98	12.7	PL 50 12 1.7 EC	TB-20	9314350017894

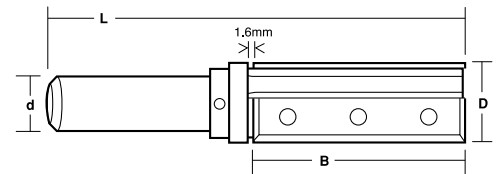

Single Flute - Straight Bit

- Use end cutting inserts for plunging and trenching
- Supplied with end cutting inserts when new

Product Group	Discount Group
R754	Z0920

Part No.	D mm	B mm	L mm	d mm	Insert No.	Barcode
RS 1230 1/2	12	30	75	12.7	PL 29.5 9 1.5 EC	9314350014527
RS 12.7 30 1/2	12.7	30	75	12.7	PL 29.5 9 1.5 EC	9314350014534
RS 1630 1/2	16	30	85	12.7	PL 29.5 12 1.5 EC	9314350014558
RS 1640 1/2	16	40	85	12.7	PL 39.5 12 1.5 EC	9314350013896
RS 1930 1/2*	19	30	85	12.7	PL 29.5 12 1.5 EC	9314350014572
RS 1940 1/2*	19	40	85	12.7	PL 39.5 12 1.5 EC	9314350013919
RS 1940 16*	19	40	85	16	PL 39.5 12 1.5 EC	9314350013926
RS 2030 1/2*	20	30	85	12.7	PL 29.5 12 1.5 EC	9314350014589
RS 2040 1/2*	20	40	85	12.7	PL 39.5 12 1.5 EC	9314350013939
RS 2040 16*	20	40	85	16	PL 39.5 12 1.5 EC	9314350013948

*These tools will be deleted from the range once current stocks are sold out.

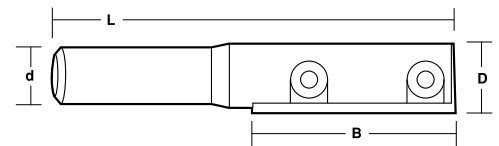

Single Flute - Straight Bit

- Use end cutting inserts for plunging and trenching

Product Group	Discount Group
R755	Z0920

Part No.	D mm	B mm	L mm	d mm	Insert No.	Barcode
RSP 12.730 1/2*	12.7	30	85	12.7	PL 29.5 9 1.5 EC	9314350019515
RSP 1640 1/2*	16	40	90	12.7	PL 39.5 9 1.5 EC	9314350019539

*These tools will be deleted from the range once current stocks are sold out.

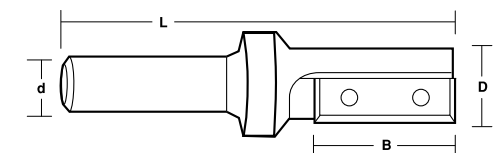

IMPORTANT: When locating inserts, hold inserts firmly into pocket when tightening screws.

NOTE: Part No's include cutter bodies complete with Inserts, Screws and Torx Key. Bearing if applicable. End Cutting Inserts, have End Cutting Clearance.

2 Flute - Bevel Trimming Bit - 22°

- Replacement bearing TB5

Product Group	Discount Group
R756	Z0920

Part No.	D mm	B mm	L mm	d mm	Insert No.	Barcode
R22 B	19	12	54	6.35	PL 12 12 1.5	9314350013872
R22 B 1/2	19	12	58	12.7	PL 12 12 1.5	9314350013889

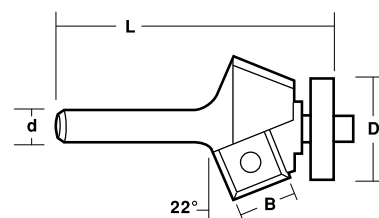

2 Flute - Bevel Trimming Bit - 45°

- Replacement bearing TB5

Product Group	Discount Group
R757	Z0920

Part No.	D mm	B mm	L mm	d mm	Insert No.	Barcode
R45 B	19	12	54	6.35	PL 12 12 1.5	9314350014596
R45 B 1/2	19	12	58	12.7	PL 12 12 1.5	9314350014602

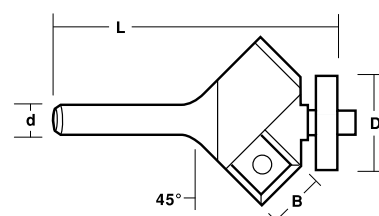

Single Flute - Vee Groove Bit - 91°

- Cuts included angle of 91°

Product Group	Discount Group
R758	Z0920

Part No.	D mm	B mm	L mm	d mm	Insert No.	Barcode
RVG 91 1/2	18	12	60	12.7	PL 12 12 1.5	9314350016552

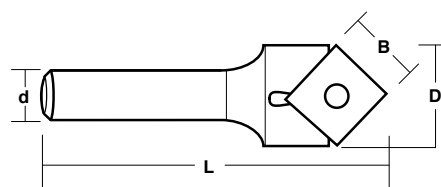

Single Flute - Vee Groove Bit - 90°

- Cuts included angle of 90°

Product Group	Discount Group
R759	Z0920

Part No.	D mm	B mm	L mm	d mm	Insert No.	Barcode
RVG 90 1/2	25	15.5	68	12.7	PLR 20 12	9314350016569

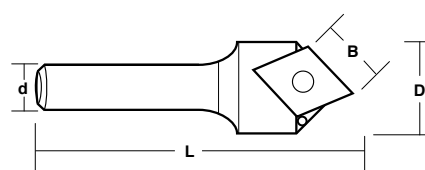

IMPORTANT: When locating inserts, hold inserts firmly into pocket when tightening screws.

NOTE: Part No's include cutter bodies complete with Inserts, Screws and Torx Key. Bearing if applicable. End Cutting Inserts, have End Cutting Clearance.

3 Flute - Surface Planer

- For use only in securely mounted machines
- Care should be taken with speed selection

Product Group **Discount Group**
R760 Z0920

Part No.	D mm	B mm	L mm	d mm	Insert No.	Barcode
R3 55121/2	55	12	78	12.7	PL 12 12 1.5	9314350014732

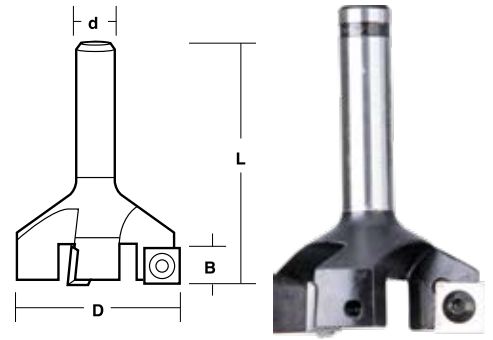

4 Flute - Surface Planer

- For use only in securely mounted machines
- Care should be taken with speed selection

Product Group **Discount Group**
R761 Z0920

Part No.	D mm	B mm	L mm	d mm	Insert No.	Barcode
R4 8012 16	80	12	83	16	PL 12 12 1.5	9314350016064
R4 8012 20	80	12	83	20	PL 12 12 1.5	9314350017137

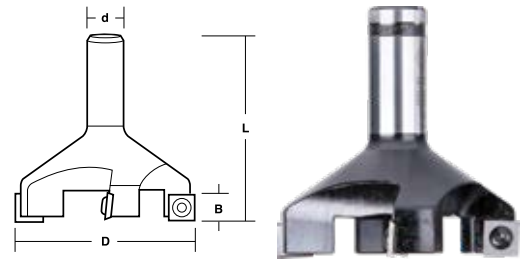

IMPORTANT: When locating inserts, hold inserts firmly into pocket when tightening screws.

NOTE: Part No's include cutter bodies complete with Inserts, Screws and Torx Key. Bearing if applicable. End Cutting Inserts, have End Cutting Clearance.

Multi Shape Profile Bit

• Use the standard range of shapes available or custom design your own shape

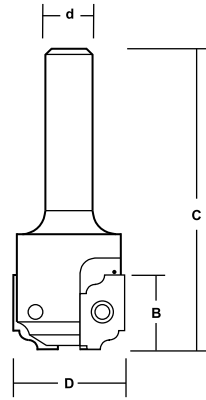

Product Group	Discount Group					
R762	Z0920					
Part No.	B mm	B2 mm	R mm	chmf	D mm	Barcode
RMST 201	9.52	-	9.52	-	-	9314350022034
RMST 202	5.9	-	3.5	-	5.9	9314350022041
RMST 203	6.6	-	5.0	-	6.6	9314350022058
RMST 204	7	-	3.5	-	7	9314350022065
RMST 205	10.45	6.01	-	35°	8.58	9314350022072
RMST 206	5	-	2.5	-	6.6	9314350022089
RMST 207	5.5	-	11.68	-	6.7	9314350022096
BLANK INSERT						
RMSTB 20122						9314350022102

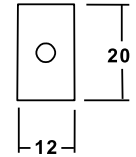
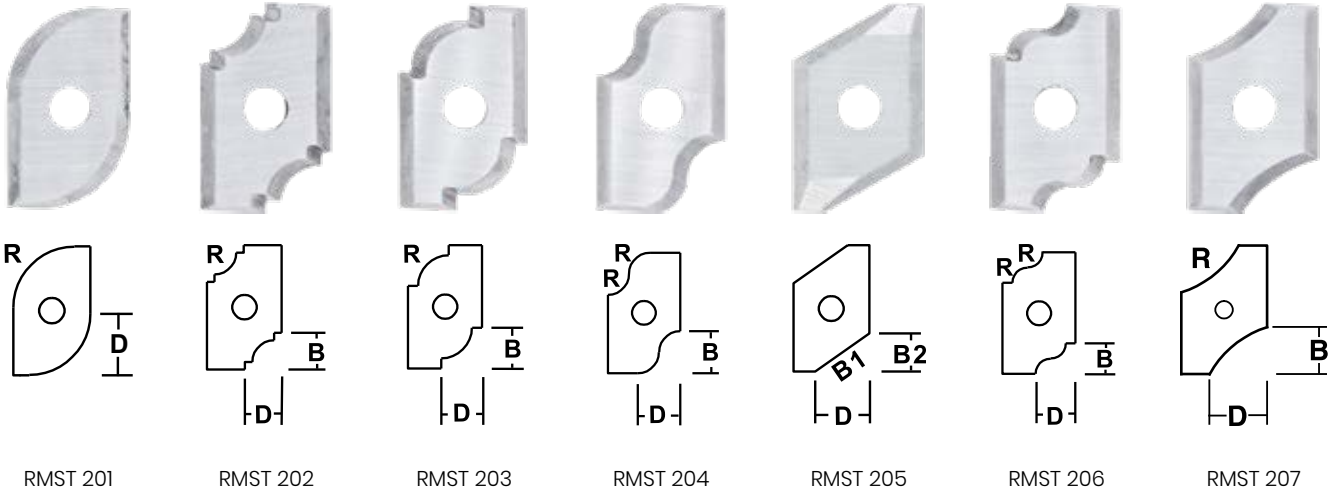

Blank inserts onto which the profile can be ground NB. These blanks will not fit onto the body until ground.
Tip Thickness 2mm.

RMSTB 20122

Multi Shape Profile Bit (Without Inserts)

• Use the standard range of shapes available or custom design your own shape

Product Group	Discount Group				
R763	Z0920				
Part No.	D mm	B mm	L mm	d mm	Barcode
RMS 2001/2	30	20	75	12.7	9314350020405

- Replacement Insert - 20 x 12 x 2.0
- Replacement Screw - M4
- Replacement Torx Key - T15

IMPORTANT: When locating inserts, hold inserts firmly into pocket when tightening screws.

Multi Shape Profile Bit

- Use the standard range of shapes available or custom design your own shape

Product Group **Discount Group**
R764 Z0920

Part No.	B mm	B2 mm	R mm	chmf	D mm	Barcode
RMST 301	11.8	-	7	-	11.8	9314350022119
RMST 302	11	-	23.35	-	13.47	9314350022126
RMST 303	19.25	13.61	-	45°	13.61	9314350022133
RMST 304	11	-	5	-	13.2	9314350022140
BLANK INSERT						
RMSTB 30202						9314350022157

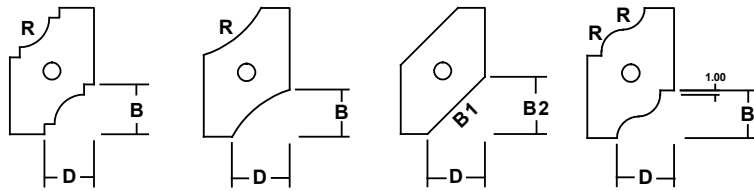
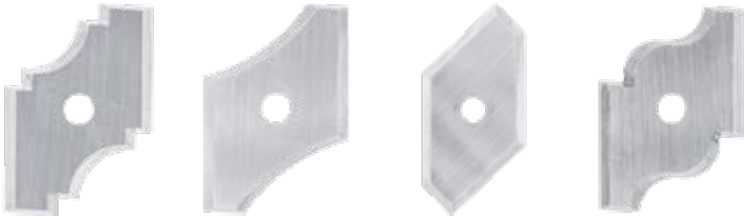
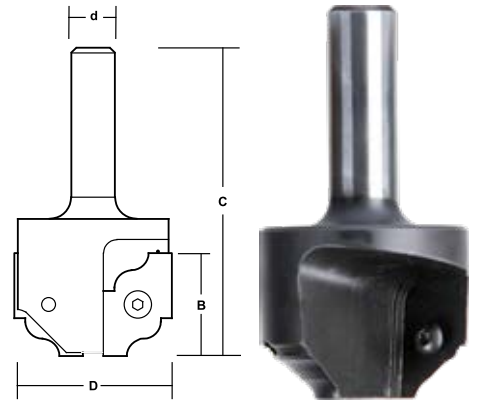

RMST 301 RMST 302 RMST 303 RMST 304

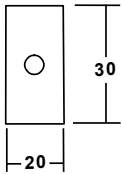

Blank inserts onto which the profile can be ground NB. These blanks will not fit onto the body until ground.
Tip Thickness 2mm.

RMSTB 30202

Multi Shape Profile Bit (Without Inserts)

- Use the standard range of shapes available or custom design your own shape

Product Group **Discount Group**
R765 Z0920

Part No.	D mm	B mm	L mm	d mm	Barcode
RMS 300 1/2	46	30	90	1/2	9314350020412
RMS 300 16	46	30	90	16	9314350020429

- Replacement Insert - 20 x 12 x 2.0
- Replacement Screw - M4
- Replacement Torx Key - T15

IMPORTANT: When locating inserts, hold inserts firmly into pocket when tightening screws.

Indexable Inserts

Product Group R766 **Discount Group** Z0920

Part No.	Dimensions (mm)			Cutting Edges	ØD	Barcode
	L	W	T			
PL 7.65 12 1.5	7.65	12	1.5	2	4	9314350024014
PL 9.0 12 1.5	9	12	1.5	2	4	9314350024021
PL 15 12 1.5	15	12	1.5	2	4	9314350024038
PL 20 12 1.5	20	12	1.5	2	4	9314350024045

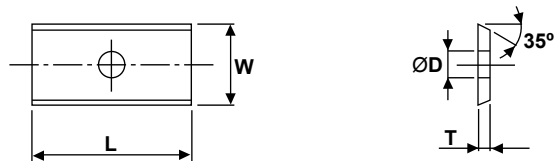

Product Group R767 **Discount Group** Z0920

Part No.	Dimensions (mm)			Cutting Edges	ØD	Barcode
	L	W	T			
PL 25 12 1.5	25	12	1.5	2	4	9314350024052
PL 30 12 1.5	30	12	1.5	2	4	9314350024069
PL 40 12 1.5	40	12	1.5	2	4	9314350024076
PL 50 12 1.5	50	12	1.5	2	4	9314350024083
PL 60 12 1.5	60	12	1.5	2	4	9314350024090

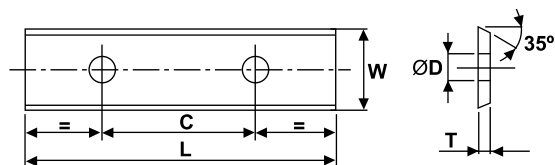

Product Group R768 **Discount Group** Z0920

Part No.	Dimensions (mm)			Cutting Edges	ØD	Barcode
	L	W	T			
PL 12 12 1.5	12	12	1.5	4	4	9314350024120



Product Group D769 **Discount Group** Z0920

Part No.	Dimensions (mm)			Cutting Edges	ØD	Barcode
	L	W	T			
PL 14 14 1.5	14	14	1.5	4	8.5	9314350024137
PL 14 14 2	14	14	2	4	6.5	9314350024144



Product Group R770 **Discount Group** Z0920

Part No.	Dimensions (mm)			Cutting Edges	ØD	Barcode
	L	W	T			
PL 19.5 12 1.5 E/C	19.5	12	1.5	4	4	9314350024151

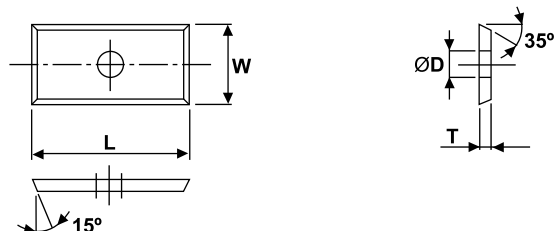

EC = End Cut

IMPORTANT: When locating inserts, hold inserts firmly into pocket when tightening screws.

Product Group R771 **Discount Group** Z0920

Part No.	Dimensions (mm)			Cutting Edges	ØD	Barcode
	L	W	T			
PL 29.5 9 1.5 EC	29.5	9	1.5	4	4	9314350024168
PL 29.5 12 1.5 E/C	29.5	12	1.5	4	4	9314350024175
PL 39.5 9 1.5 E/C	39.5	9	1.5	4	4	9314350024182
PL 39.5 12 1.5 EC	39.5	12	1.5	4	4	9314350024199
PL 49.5 12 1.5 EC	49.5	12	1.5	4	4	9314350024205
PL 59.5 12 1.5 EC	59.5	12	1.5	4	4	9314350024212

EC = End Cut

Product Group R772 **Discount Group** Z0920

Part No.	Dimensions (mm)			Cutting Edges	ØD	Barcode
	L	W	T			
PL 50 12 1.7 E/C	50	12	1.7	4	4	9314350024229

EC = End Cut

Product Group R773 **Discount Group** Z0920

Part No.	Dimensions (mm)			Cutting Edges	ØD	Barcode
	L	W	T			
PLR 20 12	20	12	1.5	2	4	9314350024236

Product Group R774 **Discount Group** Z0920

Part No.	Dimensions (mm)			Cutting Edges	ØD	Barcode
	L	W	T			
PLT 22	n/a	22	2	3	6.5	9314350024243

Product Group R775 **Discount Group** Z0920

Part No.	Dimensions (mm)			Cutting Edges	ØD	Barcode
	L	W	T			
PLS 18	18	18	1.95	4	10.3	9314350024250

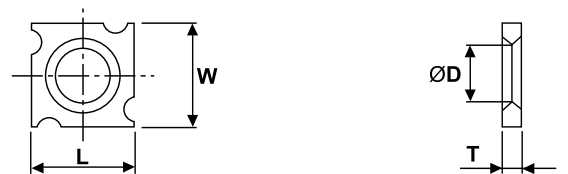
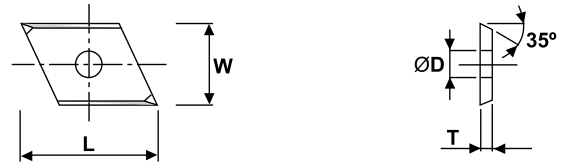
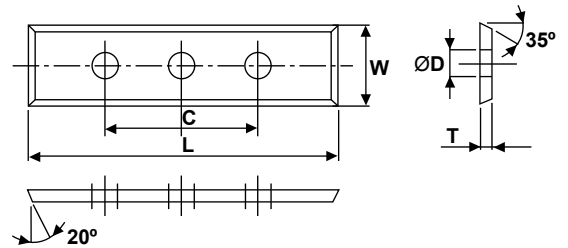
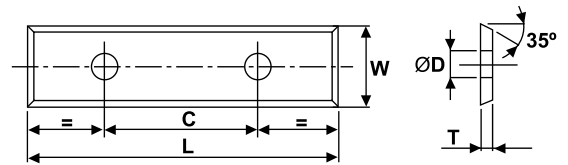

Replacement parts

- Replacement inserts & parts for replacement insert router bits

Part No.	Replacement Parts Description	
T10	Torx Key	All bits prefix RSP
T15	Torx Key	All other bits
M4	Torx Head Screw	All bits prefix R & RV
M3.5	Torx Head Screw	All bits prefix RS
M3	Torx Head Screw	All bits prefix RSP
M4	Bearing Screw	All bits
TB5	Replacement Bearing	All bits prefix R
TB4 or TB20 or TB18	Replacement Bearing	All bits prefix RV

NOTE

- All straight Router Bits without bearings or with a bearing on the shank, are supplied with end cutting inserts.
- Inserts can be removed and replaced without removing cutter from the routing machine.

CAUTION

- DO NOT OVERTIGHTEN TORX SCREWS
- When tightening screws, ensure that inserts are held firmly into pocket for correct location
- Ensure tip seating is free of burs and resin when changing blades.

IMPORTANT: When locating inserts, hold inserts firmly into pocket when tightening screws.



DIAMOND TIPPED (PCD) & COATED ROUTER BITS

- 116** 45° CHAMFER BIT
- 116** 45° INVERTED CHAMFER BIT
- 120** DIAMOND (PCD) TIPPED FLUSH TRIMMING BIT
- 122** HINGE BORING BIT
- 121** PROFILE BIT - ROUNDING OVER BIT
- 121** PROFILE BIT - VEE GROOVE / CHAMFER BIT
- 117** REPLACEMENT BEARING - RUBBER SEALED
- 116** ROUNDING OVER BIT
- 118** STRAIGHT BIT
- 120** STRAIGHT BIT - EXTREME PERFORMANCE
- 119** STRAIGHT BIT - HIGH PERFORMANCE
- 119** STRAIGHT FLUTE
- 123** THROUGH BIT
- 117** TRIM BIT
- 122** WOOD BORING BIT

Rounding Over Bit

- Ideal for use in a wide range of materials such as marble, granite, fibreglass, ceramics, solid surface materials and some types of plastics, glass and graphite

Product Group R776 **Discount Group** Z0916

Part No.	A mm	B mm	C mm	R Radius mm	Bearing mm	Shank inch	Barcode
DIACR 3.5 MB 1/2	27	8	65	3.5	TBRS 40	1/2	9314350017931
DIACR 6 MB 1/2	30	14	70	6	TBRS 41	1/2	9314350017948
DIACR 10 MB 1/2	37	16	75	10	TBRS 40	1/2	9314350017955
DIACR 12 MB 1/2	43	18	75	12	TBRS 41	1/2	9314350017962

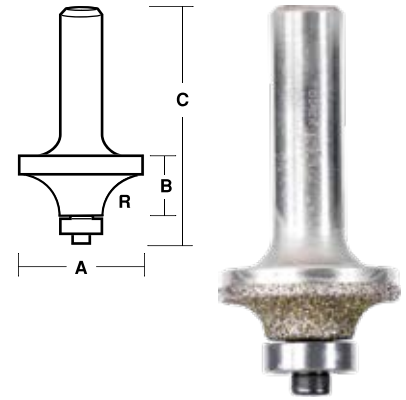

45° Chamfer Bit

- Ideal for use in a wide range of materials such as marble, granite, fibreglass, ceramics, solid surface materials and some types of plastics, glass and graphite

Product Group R778 **Discount Group** Z0916

Part No.	A mm	B mm	C mm	Bearing mm	Shank inch	Barcode
DIACR 45 B 1/2	30	14	75	TBRS 41	1/2	9314350017986

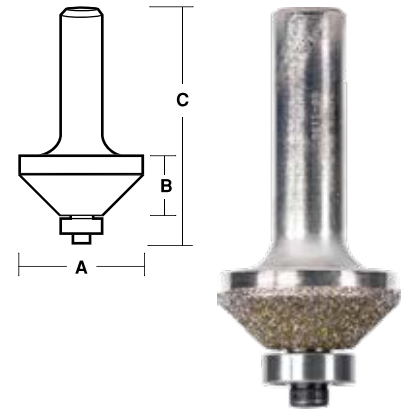

45° Inverted Chamfer Bit

- Ideal for use in a wide range of materials such as marble, granite, fibreglass, ceramics, solid surface materials and some types of plastics, glass and graphite

Product Group R784 **Discount Group** Z0916

Part No.	A mm	B mm	C mm	Bearing mm	Shank inch	Barcode
DIACR 135 B 1/2	30	17	75	TBRS 42	1/2	9314350017979

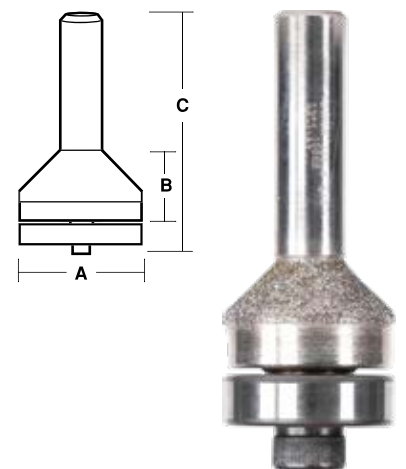

Trim Bit

- Ideal for use in a wide range of materials such as marble, granite, fibreglass, ceramics, solid surface materials and some types of plastics, glass and graphite

Product Group R777 **Discount Group** Z0916

Part No.	A mm	B mm	C mm	Bearing mm	Shank inch	Barcode
DIACR12730 B1/2	12.7	30	70	TBRS 43	1/2	9314350017993
DIACR12730 B	12.7	30	70	TBRS 43	1/4	9314350026599

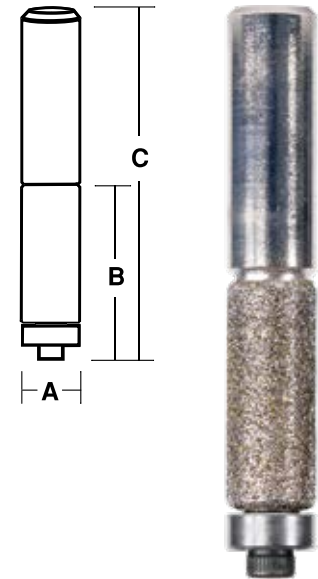

Replacement Bearing - Rubber Sealed

- Overall diameters include: 12.7mm, 16mm, 19mm & 30mm

Product Group R779 **Discount Group** Z0916

Part No.	OD mm	ID mm	B mm	Barcode
TBRS 40	19	5	6	9314350018013
TBRS 41	16	5	5	9314350018020
TBRS 42	30	10	9	9314350018037
TBRS 43	12.7	4.8	4.8	9314350018006

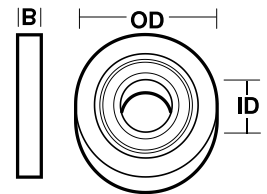

Straight Bit

- For routing panels of raw and coating hardboard, MDF and multi-layer panels
- Polished diamond
- Sheer angle tips
- Open flutes provide for faster and easier chip clearance

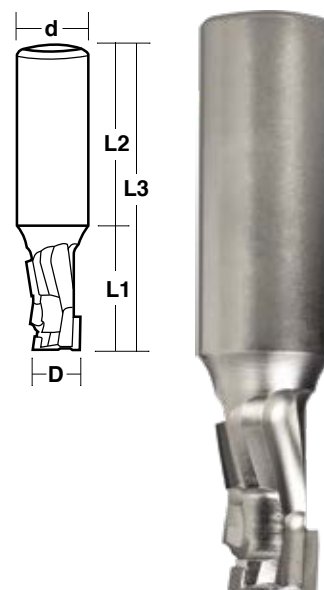

Product Group		Discount Group						Right Hand
P001		Z0914						
Part No.	D	L1	d	L2	L3	Z	Barcode	
	mm	mm	mm	mm	mm	mm		
DIATR 10M 12	10	25	12	40	75	3+1	9314350018693	
DIATR 12M 12	12	25	12	40	75	3+1	9314350018709	
DIATR XE 12M 12	12	35	12	40	85	4+1	9314350020436	
DIATR 12M 25	12	25	25	55	75	3+1	9314350020443	
DIATR 14M 16	14	25	16	50	85	3+1	9314350020450	
DIATR 16M 16	16	25	16	50	85	3+1	9314350020467	
DIATR XE 16M 16	16	35	16	50	95	4+1	9314350020474	
DIATR XXE 16M 16	16	43	16	50	103	5+1	9314350020481	
DIATR 16M 20	16	25	20	50	85	3+1	9314350018716	
DIATR XE 16M 20	16	35	20	50	95	4+1	9314350020498	
DIATR XXE 16M 20	16	43	20	50	103	5+1	9314350020504	
DIATR 18M 16	18	25	16	50	85	3+1	9314350020511	
DIATR XE 18M 16	18	35	16	50	96	4+1	9314350020528	
DIATR 18M 20	18	25	20	50	85	3+1	9314350018723	
DIATR XE 18M 20	18	35	20	50	96	4+1	9314350018839	
DIATR XXE 18M 20	18	43	20	50	103	5+1	9314350020535	
DIATR 18M 25	18	25	25	55	90	3+1	9314350020542	
DIATR XE 18M 25	18	35	25	55	100	4+1	9314350020559	
DIATR XXE 18M 25	18	43	25	55	108	5+1	9314350020566	
DIATR 20M 20	20	25	20	50	85	3+1	9314350018730	
DIATR XE 20M 20	20	35	20	50	95	4+1	9314350020573	
DIATR XXE 20M 20	20	43	20	50	103	5+1	9314350023765	
DIATR XXXE 20M 20	20	52	20	50	112	6+1	9314350020597	
DIATR 20M 25	20	25	25	55	90	3+1	9314350020603	
DIATR XE 20M 25	20	35	25	55	100	4+1	9314350020610	
DIATR XXE 20M 25	20	43	25	55	108	5+1	9314350020627	
DIATR XXXE 20M 25	20	52	25	55	117	6+1	9314350020634	

Product Group		Discount Group						Left Hand
P002		Z0914						
Part No.	D	L1	d	L2	L3	Z	Barcode	
	mm	mm	mm	mm	mm	mm		
DIATL 10M 12	10	25	12	40	75	3+1	9314350020641	
DIATL 12M 12	12	25	12	40	75	3+1	9314350020658	
DIATL XE 12M 12	12	35	12	40	85	4+1	9314350020665	
DIATL 12M 25	12	25	25	55	75	3+1	9314350020672	
DIATL 14M 16	14	25	16	50	85	3+1	9314350020689	
DIATL 16M 16	16	25	16	50	85	3+1	9314350020696	
DIATL XE 16M 16	16	35	16	50	95	4+1	9314350020702	
DIATL XXE 16M 16	16	43	16	50	103	5+1	9314350020719	
DIATL 16M 20	16	25	20	50	85	3+1	9314350020726	
DIATL XE 16M 20	16	35	20	50	95	4+1	9314350020733	
DIATL XXE 16M 20	16	43	20	50	103	5+1	9314350020740	
DIATL 18M 16	18	25	16	50	85	3+1	9314350020757	
DIATL XE 18M 16	18	35	16	50	96	4+1	9314350020764	
DIATL 18M 20	18	25	20	50	85	3+1	9314350020771	
DIATL XE 18M 20	18	35	20	50	96	4+1	9314350020788	
DIATL XXE 18M 20	18	43	20	50	103	5+1	9314350020795	
DIATL 18M 25	18	25	25	55	90	3+1	9314350020801	
DIATL XE 18M 25	18	35	25	55	100	4+1	9314350020818	
DIATL XXE 18M 25	18	43	25	55	108	5+1	9314350020823	
DIATL 20M 20	20	25	20	50	85	3+1	9314350020832	
DIATL XE 20M 20	20	35	20	50	95	4+1	9314350020849	
DIATL XXE 20M 20	20	43	20	50	103	5+1	9314350020836	
DIATL XXXE 20M 20	20	52	20	50	112	6+1	9314350020863	
DIATL 20M 25	20	25	25	55	90	3+1	9314350020870	
DIATL XE 20M 25	20	35	25	55	100	4+1	9314350020887	
DIATL XXE 20M 25	20	43	25	55	108	5+1	9314350020894	
DIATL XXXE 20M 25	20	52	25	55	117	6+1	9314350020900	

Straight Flute

- Ideal for CNC routing and contouring MDF, HDF, Plywood, sandwich panels (with or without veneer, paper or plastic coating)
- Full carbide bodies up to 12mm diameter

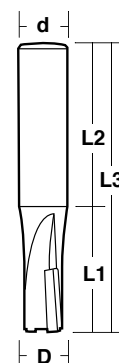

Product Group	Discount Group	Right Hand							
P003	Z0914	Part No.	D	L1	d	L2	L3	Z	Barcode
			mm	mm	mm	mm	mm	mm	
		DIATR S 6M 12	6	12	12	40	70	1	9314350020917
		DIATR S 8M 12	8	12	12	40	70	2	9314350020924
		DIATR S 10M 12	10	12	12	40	70	2	9314350020931
		DIATR SX 10M 12	10	22	12	40	70	2	9314350026315
		DIATR S 12M 12	12	25	12	40	70	2	9314350020955
		DIATR S 16M 16	16	25	16	50	85	2	9314350020962
		DIATR SXE 16M 16	16	35	16	50	95	2	9314350020979

Product Group	Discount Group	Left Hand							
P004	Z0914	Part No.	D	L1	d	L2	L3	Z	Barcode
			mm	mm	mm	mm	mm	mm	
		DIATL S 6M 12	6	12	12	40	70	1	9314350020986
		DIATL S 8M 12	8	12	12	40	70	2	9314350020993
		DIATL S 10M 12	10	12	12	40	70	2	9314350021006
		DIATL SX 10M 12	10	22	12	40	70	2	9314350046795
		DIATL S 12M 12	12	25	12	40	70	2	9314350021020
		DIATL S 16M 16	16	25	16	50	85	2	9314350021037
		DIATL SXE 16M 16	16	35	16	50	95	2	9314350021044

Straight Bit - High Performance

- High performance tools for routing panels of raw and coated board, MDF, and multi-layer panels.
- Shear angle tips allow for increased feeds and low noise
- Polished diamond provides excellent finish
- Open flutes provide faster and easier chip clearance

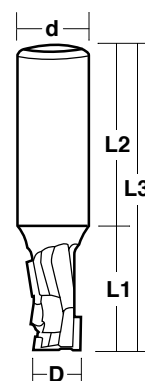

Product Group	Discount Group	Right Hand							
P005	Z0914	Part No.	D	L1	d	L2	L3	Z	Barcode
			mm	mm	mm	mm	mm	mm	
		DIATR HP 18M 20	18	28	20	50	85	6+1	9314350021051
		DIATR XEHP 18M 20	18	35	20	50	95	7+1	9314350021068
		DIATR HP 18M 25	18	28	25	55	90	6+1	9314350021075
		DIATR XEHP 18M 25	18	35	25	55	100	7+1	9314350021082
		DIATR HP 20M 20	20	28	20	50	85	6+1	9314350021099
		DIATR XEHP 20M 20	20	35	20	50	95	7+1	9314350021105
		DIATR XXEHP 20M 20	20	48	20	50	110	9+1	9314350021112
		DIATR HP 20M 25	20	28	25	55	90	6+1	9314350021129
		DIATR XEHP 20M 25	20	35	25	55	100	7+1	9314350021136
		DIATR XXEHP 20MM 25	20	48	<->	55	115	9+1	9314350021143

Product Group	Discount Group	Left Hand							
P006	Z0914	Part No.	D	L1	d	L2	L3	Z	Barcode
			mm	mm	mm	mm	mm	mm	
		DIATL HP 18M 20	18	28	<->	50	85	6+1	9314350021242
		DIATL XEHP 18M 20	18	35	20	50	95	7+1	9314350021167
		DIATL HP 18M 25	18	28	25	55	90	6+1	9314350021174
		DIATL XEHP 18M 25	18	35	25	55	100	7+1	9314350021181
		DIATL HP 20M 20	20	28	20	50	85	6+1	9314350021198
		DIATL XEHP 20M 20	20	35	20	50	95	7+1	9314350021204
		DIATL XXEHP 20M 20	20	48	20	50	110	9+1	9314350021211
		DIATL HP 20M 25	20	28	25	55	90	6+1	9314350021228
		DIATL XEHP 20M 25	20	35	25	55	100	7+1	9314350021235
		DIATL XXEHP 20MM 25	20	48	<->	55	115	9+1	9314350021242

Straight Bit - Extreme Performance

- Helical pattern router bit for raw and coated panels, MDF, multi layer panels, etc.
- Thick tips provide for multiple resharpens
- Two way rotation
- Low noise
- Fast chip discharge
- For use in CNC machines

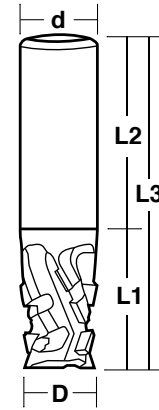

Product Group		Discount Group						Right Hand
P007		Z0914						
Part No.	D	L1	d	L2	L3	Z	Barcode	
	mm	mm	mm	mm	mm	mm		
DIATR XP 20M 20	20	23	20	50	83	5+1	9314350021259	
DIATR XP 20M 25	20	28	25	55	93	7+1	9314350021266	
DIATR XE XP 20M 25	20	35	25	55	100	8+1	9314350021273	
DIATR XP 25M 20	25	23	20	50	83	5+1	9314350021280	
DIATR XP 25M 25	25	23	25	55	88	5+1	9314350021297	
DIATR XE XP 25M 25	25	35	25	55	100	8+1	9314350021303	
DIATR XXE XP 25M 25	25	45	25	55	110	10+1	9314350021310	
DIATR XXXE XP 25M 25	25	55	25	55	120	13+1	9314350021327	

Product Group		Discount Group						Left Hand
P008		Z0914						
Part No.	D	L1	d	L2	L3	Z	Barcode	
	mm	mm	mm	mm	mm	mm		
DIATL XP 20M 20	20	23	20	50	83	5+1	9314350021334	
DIATL XP 20M 25	20	28	25	55	93	7+1	9314350021341	
DIATL XE XP 20M 25	20	35	25	55	100	8+1	9314350021358	
DIATL XP 25M 20	25	23	20	50	83	5+1	9314350021365	
DIATL XP 25M 25	25	23	25	55	88	5+1	9314350021372	
DIATL XE XP 25M 25	25	35	25	55	100	8+1	9314350021389	
DIATL XXE XP 25M 25	25	45	25	55	110	10+1	9314350021396	
DIATL XXXE XP 25M 25	25	55	25	55	120	13+1	9314350021402	

Diamond (PCD) Tipped Flush Trimming Bit

- Made with Polycrystalline Diamond PCD Tips
- PCD tips keep a sharp cutting edge much longer than tungsten carbide tips
- Excellent for extremely hard laminates

Product Group		Discount Group							
R535		Z0914							
Part No.	A		B		C		Bearing No.	Shank inch	Barcode
	inch	mm	inch	mm	inch	mm			
DIATR S 8012 B	3/8	9.5	1/2	12.7	2-3/32	53.2	TB9	1/4	9314350025592
DIATR S 8016 B	1/2	12.7	5/8	15.9	2-7/32	56.4	TB11	1/4	9314350025608
DIATR S 8016 B 1/2	1/2	12.7	5/8	15.9	2-13/16	71.4	TB11	1/2	9314350025615

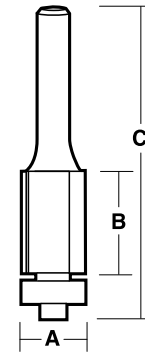

Profile Bit – Rounding Over Bit

• As well as the standard range of bits below, custom bits can also be manufactured.

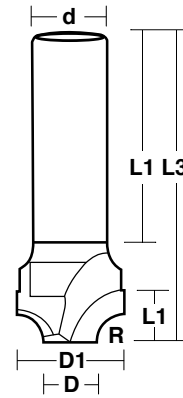

Product Group **Discount Group**
P011 Z0914

Part No.	D mm	D1 mm	R mm	L1 mm	d mm	L2 mm	L3 mm	Barcode
DIAT RO 6MR 16	24	12	6	11	16	45	50	9314350021419
DIAT RO 10MR 16	32	12	10	15	16	45	70	9314350021426
DIAT RO 12MR 16	36	12	12	17	16	45	72	9314350021433

Profile Bit – Vee Groove / Chamfer Bit

• As well as the standard range of bits below, custom bits can also be manufactured.

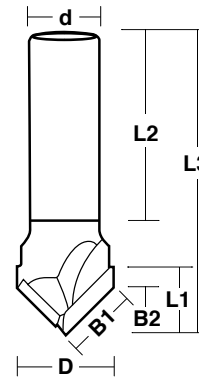

Product Group **Discount Group**
P012 Z0914

Part No.	D mm	Angle mm	B1 mm	B2 mm	L1 mm	d mm	L2 mm	L3 mm	Barcode
DIAT VGC 45D 16	22.63	45°	16	11.31	16.31	16	45	71.3	9314350021440

Hinge Boring Bit

- 10mm shank with flat
- For use on point-to-point boring and line machines on raw, melamine and MDF panels

Product Group P013
Discount Group Z0914

Right Hand

Part No.	D mm	L1 mm	d mm	L2 mm	L3 mm	Z mm	Barcode
DIAT WD 15 R 57	15	32	10	25	57	4	9314350021457
DIAT WD 30 R 57	30	32	10	25	57	4	9314350021464
DIAT WD 30 R 70	30	45	10	25	70	4	9314350021471
DIAT WD 35 R 57	35	32	10	25	57	4	9314350021488
DIAT WD 35 R 70	35	45	10	25	70	4	9314350021495
DIAT WD 40 R 57	40	32	10	25	57	4	9314350021501
DIAT WD 40 R 70	40	45	10	25	70	4	9314350021518

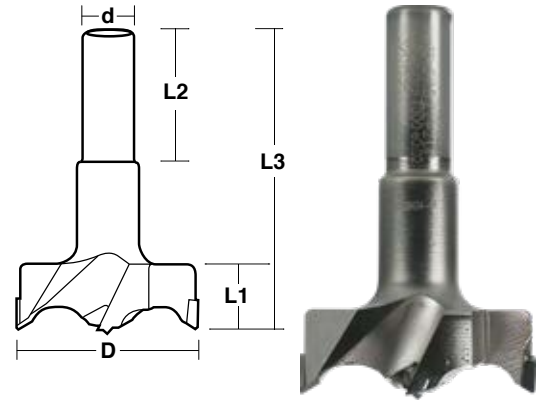

Product Group P014
Discount Group Z0914

Left Hand

Part No.	D mm	L1 mm	d mm	L2 mm	L3 mm	Z mm	Barcode
DIAT WD 15 L 57	15	32	10	25	57	4	9314350021525
DIAT WD 30 L 57	30	32	10	25	57	4	9314350021532
DIAT WD 30 L 70	30	45	10	25	70	4	9314350021549
DIAT WD 35 L 57	35	32	10	25	57	4	9314350021556
DIAT WD 35 L 70	35	45	10	25	70	4	9314350021563
DIAT WD 40 L 57	40	32	10	25	57	4	9314350021570
DIAT WD 40 L 70	40	45	10	25	70	4	9314350021587

Wood Boring Bit

- Flat bottom (10mm shank with flat)
- For use on point-to-point boring and multi-spindle machines on raw, melamine and MDF panels.

Product Group P015
Discount Group Z0914

Right Hand

Part No.	D mm	L1 mm	d mm	L2 mm	L3 mm	Z mm	Barcode
DIAT WD 5 R 57	5	32	10	25	57	1	9314350022836
DIAT WD 5 R 70	5	45	10	25	70	1	9314350022843
DIAT WD 6 R 57	6	32	10	25	57	1	9314350022850
DIAT WD 6 R 70	6	45	10	25	70	1	9314350022867
DIAT WD 8 R 57	8	32	10	25	57	1	9314350022874
DIAT WD 8 R 70	8	45	10	25	70	1	9314350022881
DIAT WD 10 R 57	10	32	10	25	57	1	9314350022898
DIAT WD 10 R 70	10	45	10	25	70	1	9314350022904

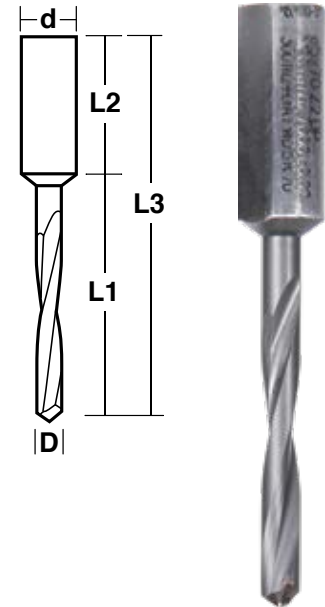

Product Group P016
Discount Group Z0914

Left Hand

Part No.	D mm	L1 mm	d mm	L2 mm	L3 mm	Z mm	Barcode
DIAT WD 5 L 57	5	32	10	25	57	1	9314350022911
DIAT WD 5 L 70	5	45	10	25	70	1	9314350022928
DIAT WD 6 L 57	6	32	10	25	57	1	9314350022935
DIAT WD 6 L 70	6	45	10	25	70	1	9314350022942
DIAT WD 8 L 57	8	32	10	25	57	1	9314350022959
DIAT WD 8 L 70	8	45	10	25	70	1	9314350022966
DIAT WD 10 L 57	10	32	10	25	57	1	9314350022973
DIAT WD 10 L 70	10	45	10	25	70	1	9314350022980

Through Bit

- 10mm shank with flat
- Makes through holes in raw, melamine and MDF panels
- For multi-spindle machines

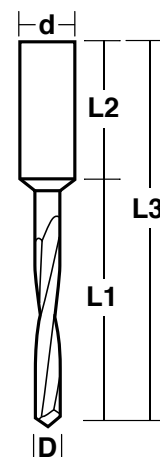

<i>Product Group</i>		<i>Discount Group</i>						Right Hand
P017		Z0914						
Part No.	D mm	L1 mm	d mm	L2 mm	L3 mm	Z mm	Barcode	
DIAT WDT 5 R 57	5	32	10	25	57	1	9314350021594	
DIAT WDT 5 R 70	5	45	10	25	70	1	9314350021600	
DIAT WDT 6 R 57	6	32	10	25	57	1	9314350021617	
DIAT WDT 6 R 70	6	45	10	25	70	1	9314350021624	
DIAT WDT 8 R 57	8	32	10	25	57	1	9314350021631	
DIAT WDT 8 R 70	8	45	10	25	70	1	9314350021648	
DIAT WDT 10 R 57	10	32	10	25	57	1	9314350021655	
DIAT WDT 10 R 70	10	45	10	25	70	1	9314350021662	

<i>Product Group</i>		<i>Discount Group</i>						Left Hand
P018		Z0914						
Part No.	D mm	L1 mm	d mm	L2 mm	L3 mm	Z mm	Barcode	
DIAT WDT 5 L 57	5	32	10	25	57	1	9314350021679	
DIAT WDT 5 L 70	5	45	10	25	70	1	9314350021696	
DIAT WDT 6 L 57	6	32	10	25	57	1	9314350021693	
DIAT WDT 6 L 70	6	45	10	25	70	1	9314350021709	
DIAT WDT 8 L 57	8	32	10	25	57	1	9314350021716	
DIAT WDT 8 L 70	8	45	10	25	70	1	9314350021723	
DIAT WDT 10 L 57	10	32	10	25	57	1	9314350021730	
DIAT WDT 10 L 70	10	45	10	25	70	1	9314350021747	



DRILLING & BORING BITS

- 127** 2 FLUTE - ADJUSTABLE HINGE BORING BIT - CARBIDE TIPPED
- 137** 2 FLUTE - ROSETTE CUTTERS - CARBIDE TIPPED
- 129** 2 FLUTE - TOY WHEEL CUTTERS - CARBIDE TIPPED
- 135** ADJUSTABLE CIRCLE HOLE CUTTER
- 132** BRAD POINT BIT - HIGH CARBON STEEL
- 126** DOWEL DRILL BIT - RIGHT HAND - CARBIDE TIPPED
- 131** DRILL COUNTERSINK - CARBIDE TIPPED
- 131** DRILL COUNTERSINK - CARBIDE TIPPED - REPLACEMENT DRILL
- 131** DRILL COUNTERSINK - HSS
- 130** DRILL COUNTERSINK WITH BALL BEARING DEPTH STOP - CARBIDE TIPPED
- 130** DRILL COUNTERSINK WITH BALL BEARING DEPTH STOP - REPLACEMENT DRILL
- 133** DRILL SAW - HSS (TIN COATED)
- 135** EXPANSION DRILL BIT
- 134** FORSTNER BIT - STEEL - IMPERIAL
- 128** HINGE BORING DRILL BIT - RIGHT HAND - CARBIDE TIPPED
- 132** HOLLOW MORTICE CHISEL
- 136** PLUG CUTTERS
- 136** STEP DRILL SET
- 126** THROUGH BORING DRILL BIT - RIGHT HAND - CARBIDE TIPPED

Through Boring Drill Bit – Right Hand – Carbide Tipped

- For multi spindle machines
- Suitable for Bench Press and secured Hand Drill.
- Not suitable for portable router machines
- 10mm diameter shank x 26mm long with adjusting screw

<i>Product Group</i>		<i>Discount Group</i>				
D801		A1132		Right Hand		
Part No.	A	L	C	Shank		Barcode
	mm	mm	mm	inch	mm	
WDT5R70	5	35	70	-	10	9314350009813
WDT8R70	8	35	70	-	10	9314350009837

				Left Hand		
Part No.	A	L	C	Shank		Barcode
	mm	mm	mm	inch	mm	
WDT5L70	5	35	70	-	10	9314350009820
WDT8L70	8	35	70	-	10	9314350009844

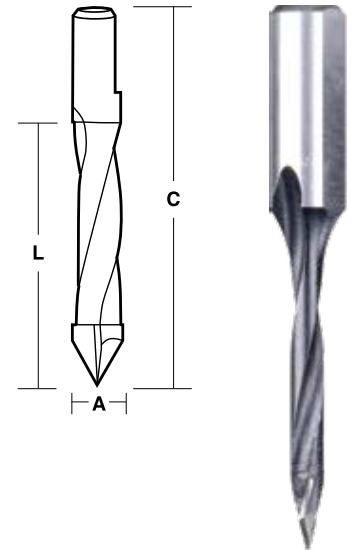

Dowel Drill Bit – Right Hand – Carbide Tipped

- For multi spindle machines
- Suitable for Bench Press and secured Hand Drill.
- Not suitable for portable router machines
- 10mm diameter shank x 27mm long (56mm) or 35mm long (70mm) with adjusting screw in end

<i>Product Group</i>		<i>Discount Group</i>				
D803		A1132		Right Hand		
Part No.	A	L	C	Shank		Barcode
	mm	mm	mm	inch	mm	
WD3R56	3	18	56	-	10	9314350021754
WD3R70	3	18	70	-	10	9314350021761
WD4R56	4	20	56	-	10	9314350019591
WD4R70	4	27	70	-	10	9314350021778
WD5R56	5	27	56	-	10	9314350009653
WD5R70	5	35	70	-	10	9314350009677
WD6R56	6	27	56	-	10	9314350009691
WD6R70	6	35	70	-	10	9314350009714
WD6.5R56	6.5	27	56	-	10	9314350021785
WD6.5R70	6.5	35	70	-	10	9314350021792
WD8R56	8	27	56	-	10	9314350009738
WD8R70	8	35	70	-	10	9314350009745
WD9R56	9	27	56	-	10	9314350009769
WD9R70	9	35	70	-	10	9314350009783
WD9.5R56	9.5	27	56	-	10	9314350009486
WD9.5R70	9.5	35	70	-	10	9314350009509
WD10R56	10	27	56	-	10	9314350009523
WD10R70	10	35	70	-	10	9314350009547
WD11R56	11	27	56	-	10	9314350009561
WD11R70	11	35	70	-	10	9314350009608
WD12R56	12	27	56	-	10	9314350009622
WD12R70	12	35	70	-	10	9314350009646
WD15R56	15	27	56	-	10	9314350021808
WD15R70	15	35	70	-	10	9314350018815

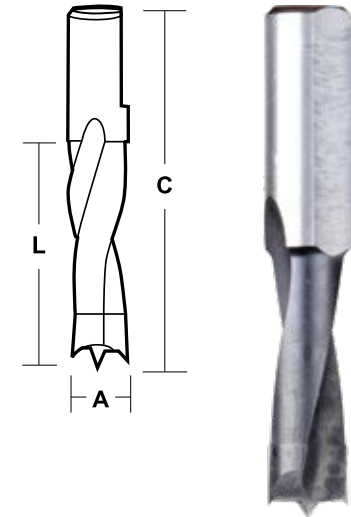

Dowel Drill Bit - Left Hand - Carbide Tipped

- For multi spindle machines
- Suitable for Bench Press and secured Hand Drill.
- Not suitable for portable router machines
- 10mm diameter shank x 27mm long (56mm) or 35mm long (70mm) with adjusting screw in end

Product Group	Discount Group					
D804	A1132		Left Hand			
Part No.	A	L	C	Shank		Barcode
	mm	mm	mm	inch	mm	
WD3L56	3	18	56	-	10	9314350021815
WD3L70	3	18	70	-	10	9314350021822
WD4L56	4	20	56	-	10	9314350019584
WD4L70	4	27	70	-	10	9314350021839
WD5L56	5	27	56	-	10	9314350009660
WD5L70	5	35	70	-	10	9314350009684
WD6L56	6	27	56	-	10	9314350009707
WD6L70	6	35	70	-	10	9314350009721
WD6.5L56	6.5	27	56	-	10	9314350021846
WD6.5L70	6.5	35	70	-	10	9314350021853
WD8L56	8	27	56	-	10	9314350009851
WD8L70	8	35	70	-	10	9314350009752
WD9L56	9	27	56	-	10	9314350009776
WD9L70	9	35	70	-	10	9314350009790
WD9.5L56	9.5	27	56	-	10	9314350009806
WD9.5L70	9.5	35	70	-	10	9314350009493
WD10L56	10	27	56	-	10	9314350009516
WD10L70	10	35	70	-	10	9314350009530
WD11L56	11	27	56	-	10	9314350009554
WD11L70	11	35	70	-	10	9314350009592
WD12L56	12	27	56	-	10	9314350009615
WD12L70	12	35	70	-	10	9314350009639
WD15L56	15	27	56	-	10	9314350021860
WD15L70	15	35	70	-	10	9314350018808

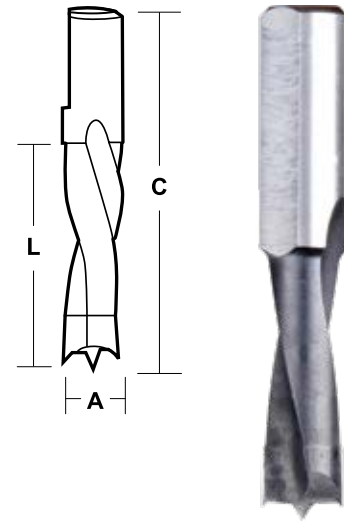

2 Flute - Adjustable Hinge Boring Bit - Carbide Tipped

- Adjusts from 20-50mm width
- Ideal for deep repetitive holes up to 75mm in depth
- For bench drill or secured portable hand drill only
- Not suitable for portable router machines

Product Group	Discount Group					
D805	A1132					
Part No.	A	B	C	Shank		Barcode
	mm	mm	mm	inch	mm	
TAHB50	22.5-48	11	97	3/8	10	9314350011724

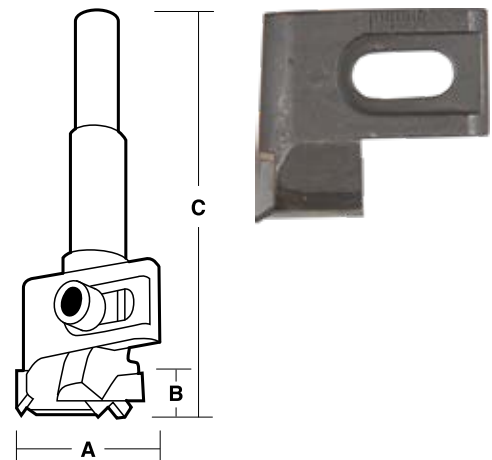

Hinge Boring Drill Bit - Right Hand - Carbide Tipped

- For multi spindle machines
- Suitable for Bench Press and secured Hand Drill.
- Not suitable for portable router machines

<i>Product Group</i>		<i>Discount Group</i>				
D806		A1132		Right Hand		
Part No.	A	C	Shank		Barcode	
	mm	mm	inch	mm		
WD20R56	20	56	-	10	9314350025400	
WD25R56	25	56	-	10	9314350010307	
WD30R56	30	56	-	10	9314350010345	
WD35R56	35	56	-	10	9314350010383	
WD25R70	25	70	-	10	9314350010321	
WD30R70	30	70	-	10	9314350010369	
WD35R70	35	70	-	10	9314350010406	

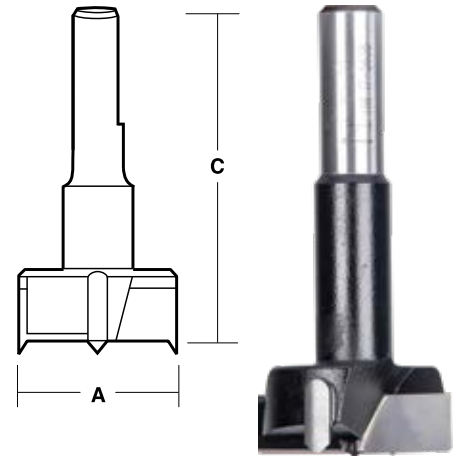

<i>Product Group</i>		<i>Discount Group</i>				
D807		A1132		Left Hand		
Part No.	A	C	Shank		Barcode	
	mm	mm	inch	mm		
WD25L56	25	56	-	10	9314350010314	
WD30L56	30	56	-	10	9314350010352	
WD35L56	35	56	-	10	9314350010390	
WD25L70	25	70	-	10	9314350010338	
WD30L70	30	70	-	10	9314350010376	
WD35L70	35	70	-	10	9314350010413	

Hinge Boring Drill Bit - Right Hand - Carbide Tipped

- For bench press and secured hand drill
- Ideal for drilling blind holes in solid wood, wood composites, plastic and laminated materials
- High quality two flute drill with two scribing teeth produces cleanly cut hole
- Not suitable for portable router machines

<i>Product Group</i>		<i>Discount Group</i>				
D808		A1132				
Part No.	A	C	Shank		Barcode	
	mm	mm	inch	mm		
TH 20 1/2	20	63.5	1/2	-	9314350002296	
TH 25 3/8	25	57.2	3/8	-	9314350002302	
TH 25 1/2	25	63.5	1/2	-	9314350002319	
TH 30 1/2	30	63.5	1/2	-	9314350002326	
TH 32 1/2	32	63.5	1/2	-	9314350002333	
TH 35 3/8	35	67	3/8	-	9314350002340	
TH 35 1/2	35	67	1/2	-	9314350007734	
TH 40 1/2	40	67	1/2	-	9314350017153	
TH 50 1/2	50	67	1/2	-	9314350017160	

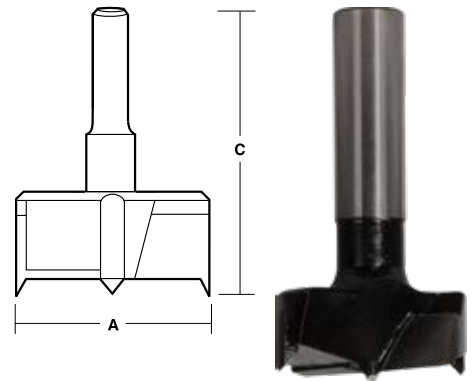

2 Flute - Toy Wheel Cutters - Carbide Tipped

- This bit gives the perfect wheel shape for toy making
- Available with a 6mm interchangeable drill
- Recommended for use in Bench or secured Hand Drills (not suitable for routing machines)

Product Group **Discount Group**
 D809 A1132

Part No.	A	A1	B	C	Shank		Barcode
	mm	mm	mm	mm	inch	mm	
TWCH 40 1/2	40	9	6.3	90	1/2	12.7	9314350023710
TWCH 50 1/2	50	13	7	92	1/2	12.7	9314350023727
TWCH 60 1/2	60	15	8	92	1/2	12.7	9314350023734

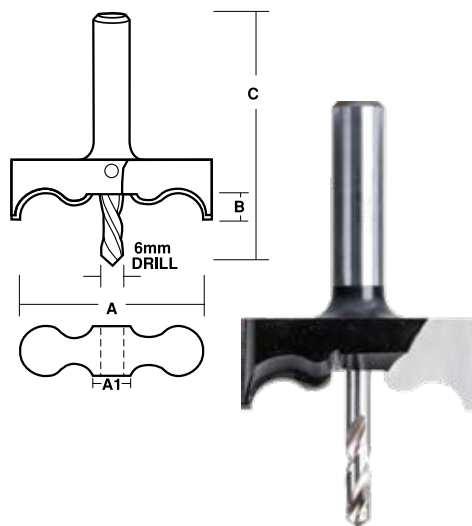

Drill Countersink with Ball Bearing Depth Stop - Carbide Tipped

- Allows precise depth adjustment when drilling screw holes
- Ideal for timber decks and furniture making
- Ball bearing depth stop with delrin cap eliminates scoring and burning on the workpiece
- Triangular shanks suit $\frac{3}{8}$ " and $\frac{10}{16}$ mm drill chucks
- Replacement drills available in a 1 or 5 pack

Product Group	Discount Group
C500	A1106

Part No.	A mm	A2 mm	B mm	C mm	Screw Gauge	Replacement Drill	Barcode
DCS3.2 DS	3.2	15	7.3	65	#8	DCSRD3.2DS	9314350025707
DCS3.5 DS	3.5	16	7.1	70	#9	DCSRD3.5DS	9314350025714
DCS3.8 DS	3.8	16	7.0	75	#10	DCSRD3.8DS	9314350025721
DCS4.0 DS	4.0	16	7.0	75	#12	DCSRD4.0DS	9314350028876
DCS5.0 DS	5.0	15	6.3	86	BUGLE	DCSRD5.0DS	9314350025738

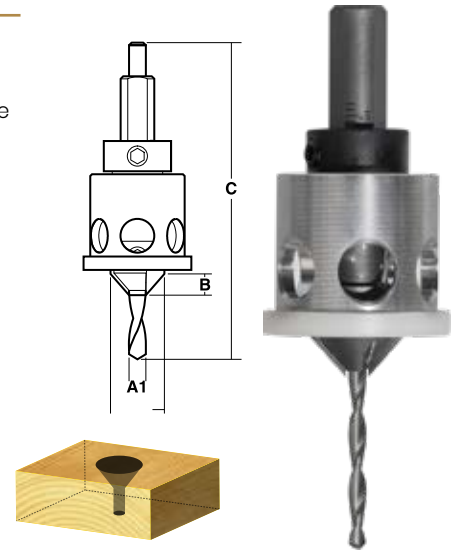

Drill Countersink with Ball Bearing Depth Stop - Replacement Drill

Product Group	Discount Group
C500	A1106

Part No.	Diameter ϕ mm	Screw Gauge	Barcode
DCSRD3.2DS	3.2	#8	9314350026490
DCSRD3.5DS	3.5	#9	9314350026506
DCSRD3.8DS	3.8	#10	9314350026513
DCSRD4.0DS	4.0	#12	9314350028852
DCSRD5.0DS	5.0	BUGLE	9314350026551

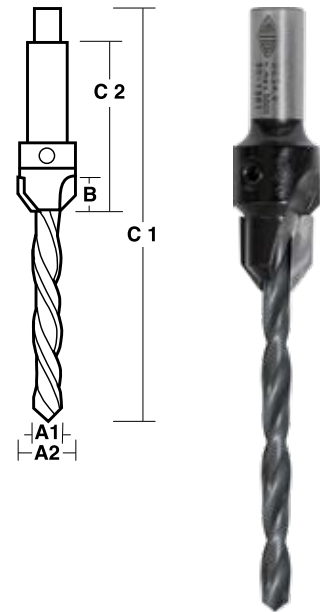

Drill Countersink – Carbide Tipped

- For drilling, chamfering in solid wood, wood composites, and plastic laminated materials
- Produces a 82° countersink

Product Group	Discount Group								
C501	A1106								
Part No.	A mm	A2 mm	C1 mm	C2 mm	Shank \varnothing mm	Replacement Drill	Barcode		
DCS2.4	2.4	9	52	41	8	DCSRD2.4	9314350012134		
DCS3.2	3.2	10	70	41	8	DCSRD3.2	9314350012141		
DCS4.0	4.0	11	73	41	8	DCSRD4.0	9314350012158		
DCS4.4	4.4	11	80	41	8	DCSRD4.4	9314350012165		
DCS5.0	5.0	12	82	46	8	DCSRD5.0	9314350012172		
DCS5.0-16	5.0	16	92	47	10	DCSRD5.0	9314350019699		
DCS6.3	6.3	13	101	46	10	DCSRD6.3	9314350012189		

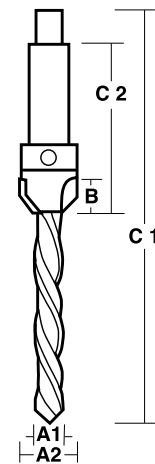

Drill Countersink – Carbide Tipped – Replacement Drill

Product Group	Discount Group			
C501	A1106			
Part No.	Diameter \varnothing mm	Barcode		
DCSRD2.4	-	9314350026476		
DCSRD3.2	-	9314350026483		
DCSRD4.0	-	9314350026520		
DCSRD4.4	-	9314350026537		
DCSRD5.0	-	9314350026544		
DCSRD6.3	-	9314350026568		

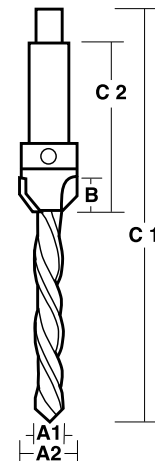

Drill Countersink – HSS

- 1/4" shank
- For drilling, chamfering in solid wood, wood composites, and plastic laminated materials

Product Group	Discount Group				
C502	A1106				
Part No.	Diameter \varnothing mm	For Screw	Replacement Drill	Barcode	
HDSC-1	2 mm	#4	REPD-2MM	9314657078901	
HDSC-2	2.4 mm	#6	REPD-2.4MM	9314657078918	
HDSC-3	3 mm	#8	REPD-3MM	9314657078925	
HDSC-4	3.175 mm	#10	REPD-3.175MM	9314657078932	
HDSC-5	3.5 mm	#12	REPD-3.5MM	9314657078949	

Part No.	Diameter \varnothing mm	Barcode
REPD-2MM	2	9314350024526
REPD-2.4MM	2.4	9314350024519
REPD-3MM	3	9314350024557
REPD-3.175MM	3.175	9314350024533
REPD-3.5MM	3.5	9314350024540



Brad Point Bit – High Carbon Steel

- For all wood projects, furniture manufacturing, carpentry and dowelling applications where exact size holes are required

<i>Product Group</i>		<i>Discount Group</i>		
D813		A1132		
Part No.	A mm	B mm	C mm	Barcode
HIGH CARBON STEEL				
BP3M	3	40	60	9314350022164
BP4M	4	48	75	9314350022171
BP5M	5	55	85	9314350022188
BP6M	6	58	90	9314350022195
BP7M	7	68	105	9314350022201
BP8M	8	75	115	9314350022218
BP9M	9	80	120	9314350022225
BP10M	10	80	120	9314350022232
BP11M	11	95	120	9314350022249
BP12M	12	95	125	9314350022256
BP13M	13	95	130	9314350022263
BP-5KIT	3, 6, 8, 10, 12mm			9314350022270

<i>Product Group</i>		<i>Discount Group</i>		
D812		A1132		
Part No.	A mm	B mm	C mm	Barcode
CARBIDE TIPPED				
TBP3M	3	38.1	76.2	9314350022287
TBP4M	4	38.1	76.2	9314350022294
TBP5M	5	50.8	88.9	9314350022300
TBP6M	6	60.3	101.6	9314350022317
TBP7M	7	60.3	110	9314350022324
TBP8M	8	60.3	120	9314350022331
TBP9M	9	60.3	120	9314350022348
TBP10M	10	60.3	120	9314350022355
TBP11M	11	60.3	150	9314350022362
TBP12M	12	60.3	150	9314350022379
TBP13M	13	60.3	150	9314350022386
TBP-5KIT	3, 6, 8, 10, 12mm			9314350022393

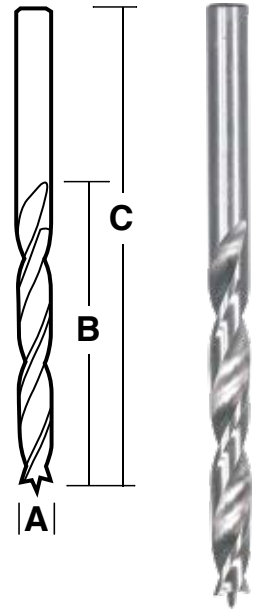

Hollow Mortice Chisel

- Combination of a drill and 4 sided chisel
- For clean, straight edges and corners in drilled holes
- 3/4" shank

<i>Product Group</i>		<i>Discount Group</i>	
D815		A1134	
Part No.	Diameter inch	Overall Length mm	Barcode
HMC08	1/4"	210mm	9314350025967
HMC10	5/16"	210mm	9314350025974
HMC12	3/8"	210mm	9314350025981
HMC14	7/16"	210mm	9314350025998
HMC16	1/2"	210mm	9314350026001
HMC18	9/16"	210mm	9314350026018
HMC20	5/8"	225mm	9314350026025
HMC24	3/4"	225mm	9314350026032
HMC28	7/8"	225mm	9314350026049
HMC32	1"	225mm	9314350026056



Drill Saw - HSS (TiN Coated)

- For cutting irregular contours and enlarging blind holes.
- For use in wood, soft metals, plastics and rubber

Product Group		Discount Group		
D816		A1134		
Part No.	A mm	B mm	C mm	Barcode
DST3M	3	40	60	9314350022409
DST4M	4	45	70	9314350022416
DST6M	6	60	92	9314350022423
DST8M	8	62	97	9314350022430
DST10M	10	70	103	9314350022447
DST12M	12	70	109	9314350022454
DST 368M KIT	1 of each 3mm, 6mm, 8mm			9314350022461

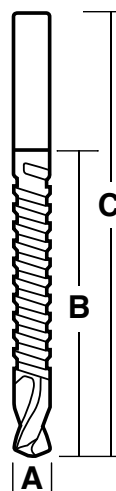

Forstner Bit - Steel - Imperial

- Quality steel forstner bits to produce flat bottom holes of various diameters
- HSS available in imperial & metric sizes
- TCT available in metric sizes

<i>Product Group</i>	<i>Discount Group</i>	
D818	A0102	
Part No.	Diameter	Barcode
STEEL - IMPERIAL		
FB 08	1/4"	9314657078277
FB 12	3/8"	9314657078284
FB 16	1/2"	9314657078291
FB 20	5/8"	9314657078253
FB 24	3/4"	9314657078260
FB 28	7/8"	9314657078307
FB 32	1"	9314657016347
FB 36	1-1/8"	9314657078321
FB 40	1-1/4"	9314657078338
FB 44	1-3/8"	9314657078345
FB 48	1-1/2"	9314657078352
FB 52	1-5/8"	9314657078369
FB 56	1-3/4"	9314657078376
FB 60	1-7/8"	9314657078383
FB 64	2"	9314657078390
FB 72	2-1/8"	9314657078406

<i>Product Group</i>	<i>Discount Group</i>	
D820	A0102	
Part No.	Diameter	Barcode
CARBIDE TIPPED		
FBT 06M	6 mm	9314657080003
FBT 10M	10 mm	9314657080010
FBT 12M	12 mm	9314657080027
FBT 16M	16 mm	9314657080034
FBT 20M	20 mm	9314657080041
FBT 22M	22 mm	9314657080058
FBT 25M	25 mm	9314657080065
FBT 28M	28 mm	9314657080072
FBT 32M	32 mm	9314657080089
FBT 35M	35 mm	9314657080096
FBT 38M	38 mm	9314657080102
FBT 42M	42 mm	9314657080119
FBT 45M	45 mm	9314657080126
FBT 48M	48 mm	9314657080133
FBT 50M	50 mm	9314657080140
FBT 54M	54 mm	9314657080157

<i>Product Group</i>	<i>Discount Group</i>	
D819	A0102	
Part No.	Diameter	Barcode
STEEL - METRIC		
FB 06M	6 mm	9314657078543
FB 10M	10 mm	9314657078567
FB 12M	12 mm	9314657078574
FB 16M	16 mm	9314657078581
FB 20M	20 mm	9314657078598
FB 22M	22 mm	9314657078604
FB 25M	25 mm	9314657078611
FB 28M	28 mm	9314657078628
FB 32M	32 mm	9314657078635
FB 35M	35 mm	9314657078642
FB 38M	38 mm	9314657078659
FB 42M	42 mm	9314657078666
FB 45M	45 mm	9314657078475
FB 48M	48 mm	9314657078673
FB 50M	50 mm	9314657078680
FB 54M	54 mm	9314657078697

<i>Product Group</i>	<i>Discount Group</i>	
D821	A0102	
Part No.	Contents	Barcode
5 PCE METRIC KIT		
FB-5KIT TCT METRIC	Contains 1 of each 16mm, 20mm, 25mm, 32mm, 35mm	9314657080164



FB-5KIT TCT METRIC



Adjustable Circle Hole Cutter

- Produces holes of between 40mm and 120mm in a wide range of materials to a depth of 35mm
- Fitted with carbide tipped blades
- Includes 2 spare steel blades, 1 spare drill and a hex key
- 10mm hex shank
- For bench drill or secured portable hand drill only. Not suitable for portable router machines



Product Group	Discount Group
D822	C0302
Part No.	Barcode
TACC-120	9314350022027

Expansion Drill Bit

- Ideal for drilling large holes in timber
- Made of hardened high carbon steel
- For use in drills only

Product Group	Discount Group	
D823	A1302	
Part No.	Size Range	Barcode
EXPDB-1	15mm - 45mm	9314350022478
EXPDB-2	22mm - 76mm	9314350022485



Step Drill Set

- 3 Piece Set - contains 3 x 2 Flute titanium coated HSS step drills
- 1/4" quick change chuck
- Self starting

Product Group	Discount Group
D828	A1106

Part No.	Contents	Barcode
HSD-3 KIT1	1 x 13 steps - 1/8"-1/2" 1 x 9 steps - 1/4"-3/4" 1 x 6 steps - 3/16"-1/2"	9314350022829



Plug Cutters

- Made of quality tool steel
- Generates timber plugs in diameters as listed
- 1/4" shank

Product Group	Discount Group
K100	A0424

Part No.	Diameter	Barcode
HPLG 16	1/2"	9314657078826
HPLG 20	5/8"	9314657078833
HPLG 08	1/4"	9314657078802
HPLG 12	3/8"	9314657078819



2 Flute - Rosette Cutters - Carbide Tipped

- Produces quality rosettes in a drill press
- Recommended RPM: 1,800 - hard wood, 3,500 - soft wood

Product Group **Discount Group**
 K103 Z0922

Part No.	A		B		C		Barcode
	inch	mm	inch	mm	inch	mm	
TRO 01 1/2	2 1/8	54	45/64	18	2 43/64	68	9314350022546
TRO 02 1/2	2 1/8	54	45/64	18	2 43/64	68	9314350022553
TRO 03 1/2	2 1/8	54	45/64	18	2 43/64	68	9314350022560
TROL 01 1/2	2 3/4	70	45/64	18	2 43/64	68	9314350022577
TROL 02 1/2	2 3/4	70	45/64	18	2 43/64	68	9314350022584
TROL 03 1/2	2 3/4	70	45/64	18	2 43/64	68	9314350022591

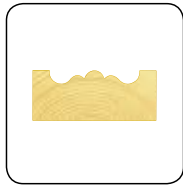

TRO 01 1/2
TROL 01 1/2

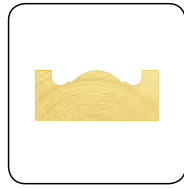

TRO 02 1/2
TROL 02 1/2

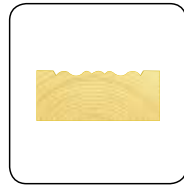

TRO 03 1/2
TROL 03 1/2

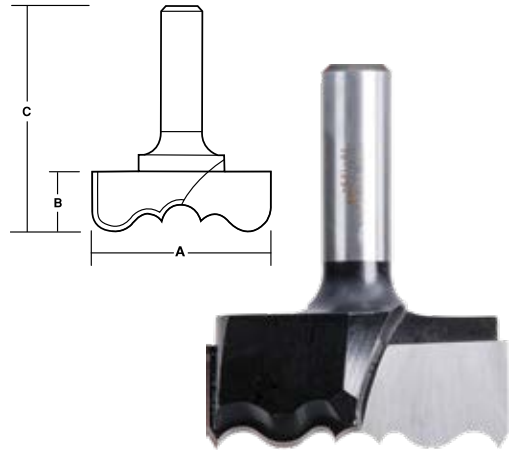

Important Safety Warning: For use in a drill press only NOT for use in a router.
Maximum RPM 5,000



SAW BLADES

- 148** COLD SAW BLADES
- 147** DIAMOND COATED SAW BLADES
- 150** HAND SAWS
- 152** ALL PURPOSE MAGIC SAWS
- 149** HOLE SAWS
- 140** TRADE BLADES

Wood Cutting – Standard Kerf

- Premium quality saw blades for portable, radial arm and bench machines
- Precision, hardened plate blades have thick micrograin carbide tips
- Designed to have optimum performance in a wide range of materials



Product Group **Discount Group**
H800 C0102

Part No.	Dia. mm	Teeth	Kerf mm	Grind	Barcode	Part No.	Dia. mm	Teeth	Kerf mm	Grind	Barcode
M6 24T 5/8	160	24	2.5	Alt. Bev.	9314350002470	M9 24T 13/8	235	24	3.0	Alt. Bev.	9314350002760
M6 24T 20MM	160	24	2.5	Alt. Bev.	9314350002487	M9 30T 5/8	235	30	3.0	Alt. Bev.	9314350002777
M6 30T 20MM	160	30	2.5	Alt. Bev.	9314350002500	M9 30T 25MM	235	30	3.0	Alt. Bev.	9314350002784
M7 40T 20MM	178	40	2.6	Alt. Bev.	9314350002562	M9 30T 30MM	235	30	3.0	Alt. Bev.	9314350002791
M184 20T 20MM	184	20	2.6	Alt. Bev.	9314350014749	M9 30T 13/8	235	30	3.0	Alt. Bev.	9314350002807
M184 30T 20MM	184	30	2.6	Alt. Bev.	9314350014756	M9 40T 25MM	235	40	3.0	Alt. Bev.	9314350002821
M184 40T 20MM	184	40	2.6	Alt. Bev.	9314350014763	M9 40T 30MM	235	40	3.0	Alt. Bev.	9314350002838
M8 24T 25MM	203	24	2.8	Alt. Bev.	9314350019744	M9 40T 13/8	235	40	3.0	Alt. Bev.	9314350002845
M8 24T 30MM	203	24	2.8	Alt. Bev.	9314350002593	M9 60T 25MM	235	60	3.0	Alt. Bev.	9314350002869
M8 30T 25MM	203	30	2.8	Alt. Bev.	9314350002623	M9 60T 30MM	235	60	3.0	Alt. Bev.	9314350002876
M8 30T 30MM	203	30	2.8	Alt. Bev.	9314350002630	M9 60T 13/8	235	60	3.0	Alt. Bev.	9314350002883
M8 40T 25MM	203	40	2.8	Alt. Bev.	9314350002661	M10 40T 5/8	250	40	3.0	Alt. Bev.	9314350002890
M8 40T 30MM	203	40	2.8	Alt. Bev.	9314350002678	M10 40T 25MM	250	40	3.0	Alt. Bev.	9314350002906
M8 60T 25MM	203	60	2.8	Alt. Bev.	9314350002708	M10 40T 30MM	250	40	3.0	Alt. Bev.	9314350002913
M8 60T 30MM	203	60	2.8	Alt. Bev.	9314350002715	M10 60T 5/8	250	60	3.0	Alt. Bev.	9314350002951
M210 24T 25MM	210	24	2.8	Alt. Bev.	9314350010949	M10 60T 25MM	250	60	3.0	Alt. Bev.	9314350002968
M210 24T 30MM	210	24	2.8	Alt. Bev.	9314350017559	M10 60T 30MM	250	60	3.0	Alt. Bev.	9314350002975
M210 30T 25MM	210	30	2.8	Alt. Bev.	9314350010963	M10 72T 5/8	250	72	3.0	Alt. Bev.	9314350002982
M210 30T 30MM	210	30	2.8	Alt. Bev.	9314350017085	M10 72T 25MM	250	72	3.0	Alt. Bev.	9314350002999
M210 40T 25MM	210	40	2.8	Alt. Bev.	9314350010987	M10 72T 30MM	250	72	3.0	Alt. Bev.	9314350003002
M210 40T 30MM	210	40	2.8	Alt. Bev.	9314350016897	M262 60T 1	262	60	3.0	Alt. Bev.	9314350018785
M210 60T 25MM	210	60	2.8	Alt. Bev.	9314350014787	M12 30T 30MM	300	30	3.2	Alt. Bev.	9314350014213
M210 60T 20MM	210	60	2.8	Alt. Bev.	9314350044425	M12 72T 25MM	300	72	3.2	Alt. Bev.	9314350017252
M9 24T 25MM	235	24	3.0	Alt. Bev.	9314350002746	M12 72T 30MM	300	72	3.2	Alt. Bev.	9314350014220
M210 60T 30MM	210	60	2.8	Alt. Bev.	9314657017092	M12 72T 11/4	300	72	3.2	Alt. Bev.	9314350024311
M9 24T 30MM	235	24	3.0	Alt. Bev.	9314350002753						

Safety Note: • Always ensure adequate guarding is in place. • Always wear eye, hand & hearing protection.
• Always follow machine manufacturers operating and safety instructions.

Wood Cutting - Thin Kerf

- Premium quality saw blades for portable, radial arm and bench machines
- Precision, hardened, thick micrograin carbide tips
- Optimum performance in a wide range of materials



Product Group H801 **Discount Group** C0102

Part No.	Dia. mm	Teeth	Kerf mm	Grind	Barcode
M-THIN6 24T 20MM	160	24	1.7	Alt. Bev.	9314350016996
M-THIN6 40T 20MM	160	40	1.7	Alt. Bev.	9314350017009
M-THIN184 20T 20MM	184	20	1.7	Alt. Bev.	9314350017016
M-THIN184 30T 20MM	184	30	1.7	Alt. Bev.	9314350017177
M-THIN184 40T 20MM	184	40	1.7	Alt. Bev.	9314350017023
M-THIN210 30T 25MM	210	30	2.2	Alt. Bev.	9314350017030

Part No.	Dia. mm	Teeth	Kerf mm	Grind	Barcode
M-THIN210 40T 25MM	210	40	2.2	Alt. Bev.	9314350017047
M-THIN235 30T 25MM	235	30	2.4	Alt. Bev.	9314350017146
M-THIN235 40T 25MM	235	40	2.4	Alt. Bev.	9314350017610
M-THIN250 100T 30MM	250	100	2.4	Alt. Bev.	9314350017078
M-THIN305 60T 1	305	60	2.8	Alt. Bev.	9314350017207
M-THIN305 80T 1	305	80	2.8	Alt. Bev.	9314350017214

Metal Cutting Saw Blades

- Premium blades for portable, radial arm and bench machines
- Precision, hardened, thick micrograin carbide tips
- Optimum performance in a wide range of materials



Product Group H803 **Discount Group** C0102

Part No.	Dia. mm	Teeth	Kerf mm	Grind	Barcode
MMET102 20T 5/8	102	20	2.2	Flat Top Grind	9314350018051
MMET115 20T 7/8	115	20	2.2	Flat Top Grind	9314350018068
MMET125 20T 7/8	125	20	2.2	Flat Top Grind	9314350018075
MMET150 30T 20MM	150	30	2.2	Flat Top Grind	9314350018082
MMET150 30T 7/8	150	30	2.2	Flat Top Grind	9314350018617
MMET184 36T 20MM	184	36	2.2	Flat Top Grind	9314350018624
MMET184 36T 7/8	184	36	2.2	Flat Top Grind	9314350018631
MMET185 48T 20MM	185	48	2.0	Flat Top Grind	9314350025318
MMET210 40T 25MM	210	40	2.6	Flat Top Grind	9314350018105
MMET210 40T 7/8	210	40	2.6	Flat Top Grind	9314350018648
MMET230 48T 25MM	230	48	2.6	Flat Top Grind	9314350018655
MMET230 48T 7/8	230	48	2.6	Flat Top Grind	9314350018662
MMET250 60T 25MM	250	60	2.6	Flat Top Grind	9314350018679
MMET305 60T 1	305	60	2.6	Flat Top Grind	9314657028777
MMET305 60T 25MM	305	60	2.6	Flat Top Grind	9314350018686

Aluminium Cutting - Negative Rake

- Premium blades for portable, radial arm and bench machines
- Precision, hardened, thick micrograin carbide tips
- Optimum performance in a wide range of materials



Product Group H802 **Discount Group** C0102

Part No.	Dia. mm	Teeth	Kerf mm	Grind	Barcode
MNF160 60T 20MM	160	60	2.2	Trip.Chip	9314350017191
MNF184 60T 20MM	184	60	2.2	Trip.Chip	9314350017221
MNF210 80T 25MM	210	80	2.8	Trip.Chip	9314350017054
MN216 24T 30MM	216	24	2.7	Trip.Chip	9314350010611
MN216 48T 30MM	216	48	2.7	Trip.Chip	9314350010628
MNF216 60T 30MM	216	60	2.7	Trip.Chip	9314350010635
MNF216 80T 30MM	216	80	2.7	Trip.Chip	9314350010642
MNF9 80T 25MM	235	80	2.8	Trip.Chip	9314350017061
MNF10 100T 25MM	250	100	2.6	Trip.Chip	9314350017184
MNF10 100T 30MM	250	100	2.8	Trip.Chip	9314350023789
MNF10 80T 30MM	250	80	3.0	Trip.Chip	9314350010604
MNF262 80T 1	262	80	3.1	Trip.Chip	9314350018792
MNF300 100T 1	300	100	2.8	Trip.Chip	9314350026582
MNF300 100T 30MM	300	100	2.8	Trip.Chip	9314350017269

Cement Sheet Cutting Blades

- Premium trade blade quality
- Heat treated blades for cutting cement sheet and other compressed, highly abrasive materials

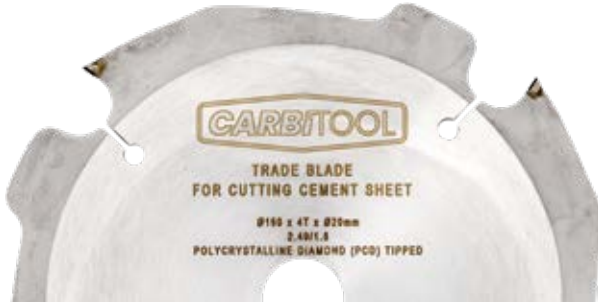

Product Group	Discount Group						
H821	C0105	Part No.	Dia. mm	Teeth	Kerf mm	Bore	Barcode
		MPCD125 4T 20MM	125	4	2.4	20	9314350026179
		MPCD160 4T 20MM	160	4	2.4	20	9314350026162
		MPCD180 4T 20MM	180	4	2.4	20	9314350025158
		MPCD250 6T 30MM	250	6	3.2	30	9314350026155
		MPCD300 8T 30MM	300	8	3.2	30	9314350026148

Precision Cutting

- Intended for sawing thin hard materials such as Bakelite, plywood and Plexiglass for a chip free finish
- For use on material 1-10mm thick
- Made to exacting European standards and cover a wide range of applications



Product Group	Discount Group					
H804	C0103	Part No.	Dia. mm	Teeth	Kerf mm	Barcode
		L5BA10N 150	150	6	2.2	9314350044463
		L5BA10N 180	180	7	2.5	9314350046603
		L5BA10N 250	225	9	2.8	9314350044562
		LPQ5BA10N 300	300	122	3.2	9314350044593
		L5BA10T3 180	180	7	1.8	9314350044470
		L5BA10T3 250	250	10	2.0	9314350044548
		L5BA10T3 300	300	12	2.2	9314350044586

Metal Cutting Saw Blades

- Specifically designed to cut corrugated iron, acrylics and metals
- Fits most 185mm hand held portable metal cutting machines



Product Group	Discount Group					
H822	C0102	Part No.	Teeth	Kerf mm	Bore	Barcode
		MMET185 48T 20MM	48	2.0	-	9314350025318

Precision Crosscut

- For cross cutting small sized timber and chipboard materials 2-20mm thick
- Superior quality micro-grain carbide teeth that enable the sharp cutting edge to be maintained longer between sharpenings



Product Group	Discount Group					
H805	C0103	Part No.	Dia. mm	Teeth	Kerf mm	Barcode
		L5BA14N 225	225	9	2.8	9314350044678
		L5BA14N 250	250	10	2.8	9314350046610
		LPQ5BA14N 250	250	10	3.2	9314350044685
		L5BA14N 300	300	14	4.0	9314350046627
		LPQ5BA14N 350	350	14	3.5	9314350044692

Safety Note: Above blades are only to be used on power saws.

- Always ensure adequate guarding is in place.
- Always wear eye, hand & hearing protection.
- Always follow machine manufacturers operating and safety instructions.

Precision Cutting

- Positive rake
- Triple chip



Product Group		Discount Group		
H806		C0103		
Part No.	Dia. mm	Teeth	Kerf mm	Barcode
LPQ5EA10N 300	300	96	3.2	9314350044746
LPQ5EA14N 300	300	72	3.2	9314350044739

Crosscut

- Suitable for cutting small to medium size timber and chipboard materials up to 6-40mm thick
- Superior quality micro-grain carbide teeth that enable the sharp cutting edge to be maintained longer between sharpenings



Product Group		Discount Group		
H807		C0103		
Part No.	Dia. mm	Teeth	Kerf mm	Barcode
L10BA19N 250	250	40	2.8	9314350044753
L10BA19N 300	300	48	3.2	9314350044760

Crosscut

- For medium to large size timber 15-90mm thick



Product Group		Discount Group		
H808		C0103		
Part No.	Dia. mm	Teeth	Kerf mm	Barcode
L10BA30N 250	250	24	2.8	9314350044814
L10BA30N 300	300	32	3.2	9314350044821
L10BA30N 350	350	36	3.5	9314350044838
L10BA30N 400	400	40	4.0	9314350044845
L10BA30N 450	450	48	4.0	9314350044852
L10BA30N 500	500	52	4.0	9314350044869

Combination Rip & Crosscut

- Suitable for materials 6-40mm thick



Product Group		Discount Group		
H809		C0103		
Part No.	Dia. mm	Teeth	Kerf mm	Barcode
L20BA19N 250	250	40	2.8	9314350044876
L20BA19N 300	300	48	3.2	9314350044883
L20BA19N 350	350	60	3.5	9314350044890
L20BA19N 400	400	68	4.0	9314350044906
L20BA19N 450	450	72	4.0	9314350044913

Combination Rip & Crosscut

- Suitable for material 15-90mm thick



<u>Product Group</u>		<u>Discount Group</u>		
H810		C0103		
Part No.	Dia. mm	Teeth	Kerf mm	Barcode
L20BA30N 250	250	24	2.8	9314350044937
L20BA30N 300	300	32	3.2	9314350044944
L20BA30N 350	350	36	3.5	9314350044951
L20BA30N 400	400	40	4.0	9314350044968
L20BA30N 500	500	52	4.0	9314350044982

Rip Saws

- For ripping larger timbers 20-125mm thick



<u>Product Group</u>		<u>Discount Group</u>		
H811		C0103		
Part No.	Dia. mm	Teeth	Kerf mm	Barcode
L20BA39N 250	250	20	2.8	9314350044999
L20BA39N 300	300	24	3.2	9314350045002
L20BA39N 350	350	28	3.5	9314350045019
L20BA39N 450	450	36	4.0	9314350045033
L20BA39N 560	560	44	4.5	9314350045057
L20BA39N 610	610	48	4.5	9314350045064

Radial Arm

- Negative hook angle for cross cutting timber in pendium or pull across crosscut saws



<u>Product Group</u>		<u>Discount Group</u>		
H812		C0103		
Part No.	Dia. mm	Teeth	Kerf mm	Barcode
LN2BA30N 300	300	30	3.1	9314350045095
LN2BA30N 350	350	36	3.5	9314350045101
LN2BA30N 400	400	40	4.0	9314350045118

Special Table Saw Blades

- 380mm (15") diameter



<u>Product Group</u>		<u>Discount Group</u>		
H813		C0103		
Part No.	Dia. mm	Teeth	Kerf mm	Barcode
L10BA30N 380	380	40	4.0	9314350040922
L5BA16N 380	380	72	4.0	9314350040977

Safety Note: • Always ensure adequate guarding is in place. • Always wear eye, hand & hearing protection. • Always follow machine manufacturers operating and safety instructions.

Scoring Saws Solid Conical



Scoring Saw Split



Product Group H814 **Discount Group** C0103

Part No.	Bore Size	Dia. mm	Teeth	Barcode
LSOLID 120X20	22	120	24	9314350045156

Product Group H995*/H996 **Discount Group** C0103

Part No.	Bore Size	Dia. mm	Teeth	Barcode
LPQSPLIT 100X20*	20	100	2x12	9314350045453
LPQSPLIT 120X20*	20	120	2x12	9314350045477
LPQSPLIT 120X22*	22	120	2x12	9314350045484
LPQSPLIT 125X20*	20	125	2x12	9314350045507
LSPLIT 100X20	20	100	2x12	9314657046634
LSPLIT 100X22	22	100	2x12	9314657046641
LSPLIT 120X20	22	120	2x12	9314657019454

Non Ferrous Metal Cutting

- For sawing aluminium and non-ferrous metals 3-12mm thick
- Negative rake
- Triple chip

Non Ferrous Metal Cutting

- For sawing aluminium and non-ferrous metals up to 6mm thick
- Negative rake
- Triple chip



Product Group H815 **Discount Group** C0103

Part No.	Dia. mm	Teeth	Kerf mm	Barcode
LN2EAM14 300	300	68	3.5	9314350045231
LN2EAM14 400	400	88	4.5	9314350045255

Product Group H816 **Discount Group** C0103

Part No.	Dia. mm	Teeth	Kerf mm	Barcode
LN2EAM10 180	180	52	2.8	9314350045286
LN2EAM10 200	200	60	2.8	9314350045293
LN2EAM10 250	250	80	2.8	9314350045316
LN2EAM10 275	275	84	3.2	9314350045323
LN2EAM10 300	300	96	3.2	9314350045330
LN2EAM10 350	350	104	3.5	9314350045347
LN2EAM10 400	400	120	4.0	9314350045354
LN2EAM10 450	450	132	4.0	9314350045361

Precision Crosscut

- For cross cutting small sized timber, chipboard, etc materials 2-20mm thick



Product Group	Discount Group			
H817	C0103			
Part No.	Dia. mm	Teeth	Kerf mm	Barcode
LPQ5BA14N 300	300	60	3.2	9314350045378

Blade/Scorer Packages

- Made to exacting European standards and cover a wide range of applications

Product Group	Discount Group			
H820	C0103			
Part No.	Description	Barcode		
LPQPKGBA72-20	300 x 72T AB + 120 x 24 x 20 Split Scorer	9314350045385		
LPQPKGBA72-22	300 x 72T AB + 120 x 24 x 22 Split Scorer	9314350045392		
LPQPKGBA96-20	300 x 96T AB + 120 x 24 x 20 Split Scorer	9314657019171		
LPQPKGBA96-22	300 x 96T AB + 120 x 24 x 22 Split Scorer	9314657019188		
LPQPKGEA72-20	300 x 72T Trip. Chip + 120 x 24 x 20 Split Scorer	9314657019164		
LPQPKGEA72-22	300 x 72T Trip. Chip + 120 x 24 x 22 Split Scorer	9314350045415		
LPQPKGEA96-20	300 x 96T Trip. Chip + 120 x 24 x 20 Split Scorer	9314350045408		
LPQPKGEA96-22	300 x 96T Trip. Chip + 120 x 24 x 22 Split Scorer	9314350045422		

* **Bench saw blades:** Diamond Tipped (PCD) Saw blades are also available on request.

Safety Note: • Always ensure adequate guarding is in place. • Always wear eye, hand & hearing protection. • Always follow machine manufacturers operating and safety instructions.

Continuous Rim

- For fast, smooth cutting in thin ceramics and stone

<i>Product Group</i>		<i>Discount Group</i>					
H823		C0104					
Part No.	Dia.		Bore Size	Diamond Depth (mm)	Kerf mm	Barcode	
	inch	mm					
DSCR 125	5	125	22.23/20	5	1.9	9314350018211	
DSCR 180	7	180	22.23/20/16	5	2.2	9314350018228	
DSCR 230	9	230	25.4/22.23	5	2.4	9314350018235	



Turbo

- For fast, smooth cutting in a wide range of masonry applications
- Cooling holes control heat build-up

<i>Product Group</i>		<i>Discount Group</i>					
H825		C0104					
Part No.	Dia.		Bore Size	Diamond Depth (mm)	Kerf mm	Barcode	
	inch	mm					
DSTR 105	4	105	20/16	7	1.78	9314350018297	
DSTR 125	5	125	22.23/20	7	2	9314350018310	
DSTR 180	7	180	22.23/20/16	7	2.2	9314350018327	
DSTR 230	9	230	25.4/22.23	7	2.8	9314350018334	



Laser Welded

- For long life in most applications

<i>Product Group</i>		<i>Discount Group</i>					
H826		C0104					
Part No.	Dia.		Bore Size	Diamond Depth (mm)	Kerf mm	Barcode	
	inch	mm					
DSLW 105	4	105	20/16	7	1.7	9314350018341	
DSLW 125	5	125	22.23/20	7	2.0	9314350018365	
DSLW 180	7	180	22.23/20/16	7	2.2	9314350018372	
DSLW 230	9	230	25.4/22.23	7	2.5	9314350018389	
DSLW 350	14	350	25.4	7	2.8	9314350022607	



HSS Circular Cold Saw for Metal – DM05 Vapor Treated

- VAPO coating covers the total surface and also affects the deep layers in the mass
- Leads to high resistance to seizing, a high degree of retention of the freezing fluid, and a lack of tension in the saw blades

Product Group **Discount Group**
 JD250 C0101

Part No.	Dia. mm	Thickness mm	Bore mm	Teeth	Pitch	Barcode
JD250X2.5X32X180	250	2.5	32	180	5	9314350045729
JD250X2.5X32X200	250	2.5	32	200	4	9314350045743
JD250X2.5X32X220	250	2.5	32	220	4	9314657025264
JD250X2.5X40X220	250	2.5	40	220	4	9314350045811
JD250X2X32X180	250	2.0	32	180	5	9314350045668
JD250X2X32X200	250	2.0	32	200	4	9314350045675
JD250X2X32X220	250	2.0	32	220	4	9314350045682



Product Group **Discount Group**
 JD275 C0101

Part No.	Dia. mm	Thickness mm	Bore mm	Teeth	Pitch	Barcode
JD275X2.5X32X180	275	2.5	32	180	5	9314350045859
JD275X2.5X32X220	275	2.5	32	220	4	9314657025455
JD275X2.5X40X180	275	2.5	40	180	5	9314350025066
JD275X2.5X40X220	275	2.5	40	220	4	9314657025196

Product Group **Discount Group**
 JD300 C0101

Part No.	Dia. mm	Thickness mm	Bore mm	Teeth	Pitch	Barcode
JD300X2.5X32X200	300	2.5	32	200	5	9314657028524
JD300X2.5X32X220	300	2.5	32	220	4	9314657025486
JD300X2.5X38X220	300	2.5	38	220	4	9314350045996
JD300X2.5X38X280	300	2.5	38	280	4	9314657019195
JD300X2.5X40X160	300	2.5	40	160	6	9314350046047
JD300X2.5X40X180	300	2.5	40	180	5	9314657025424
JD300X2.5X40X200	300	2.5	40	200	4	9314657025202
JD300X2.5X40X220	300	2.5	40	220	4	9314657025219
JD300X2.5X40X240	300	2.5	40	240	4	9314350046061

Product Group **Discount Group**
 JD315 C0101

Part No.	Dia. mm	Thickness mm	Bore mm	Teeth	Pitch	Barcode
JD315X2.5X32X180	315	2.5	32	180	5	9314350046115
JD315X2.5X32X200	315	2.5	32	200	4	9314657025271
JD315X2.5X32X220	315	2.5	32	220	4	9314657025288
JD315X2.5X32X240	315	2.5	32	240	4	9314657025462
JD315X2.5X32X260	315	2.5	32	260	4	9314350046139
JD315X2.5X40X180	315	2.5	40	180	5	9314657025226
JD315X2.5X40X200	315	2.5	40	200	4	9314657025233
JD315X2.5X40X220	315	2.5	40	220	4	9314657025240
JD315X2.5X40X240	315	2.5	40	240	4	9314350046160

Safety Note: • Always ensure adequate guarding is in place. • Always wear eye, hand & hearing protection. • Always follow machine manufacturers operating and safety instructions.

COLD SAW BLADES



Product Group **Discount Group**
 JD350 C0101

Part No.	Dia. mm	Thickness mm	Bore mm	Teeth	Pitch	Barcode
JD350X2.5X32X180	350	2.5	32	180	5	9314350025110
JD350X2.5X32X200	350	2.5	32	200	4	9314657025479
JD350X2.5X32X220	350	2.5	32	220	4	9314350025127
JD350X2.5X32X240	350	2.5	32	240	4	9314350025134
JD350X2.5X40X160	350	2.5	40	160	5	9314350046221
JD350X2.5X40X180	350	2.5	40	180	5	9314350025080
JD350X2.5X40X200	350	2.5	40	200	4	9314657025257
JD350X2.5X40X220	350	2.5	40	220	4	9314350025097
JD350X2.5X40X240	350	2.5	40	240	4	9314350025103

HSS Circular Cold Saw for Metal - Blanks With No Teeth

Product Group **Discount Group**
 JD300 C0101

Part No.	Dia. mm	Thickness mm	Bore mm	Barcode
JD300X2.5X32	300	2.5	32	9314350045941
JD300X2.5X38	300	2.5	38	9314350046030
JD300X2.5X40	300	2.5	40	9314350046108
JD315X2.5X32	315	2.5	32	9314350046153
JD315X2.5X40	315	2.5	40	9314350046184
JD350X2.5X32	350	2.5	32	9314350046214
JD350X2.5X40	350	2.5	40	9314657025295

HOLE SAWS

Adjustable Holesaw

- For glazed ceramic wall tiles
- Cuts holes from 10mm-100mm in most ceramic wall tiles

Product Group **Discount Group**
 H700 C0302

Part No.	Barcode
TATC-100	9314350022645



S52 Tenon Saw

Product Group	Discount Group
H891	C0602

- Blade is made from superior quality Alloy Steel
- 3" deep blade with brass back
- Features a beech handle



S95 Handsaw

Product Group	Discount Group
H892	C0602

- Blade is made from Alloy Spring Steel
- Taper ground with a skew back giving effortless cutting and good balance
- Features a beech handle



SDS819 Dovetail Saw

Product Group	Discount Group
H880	C0602

- Brass backed
- Blade is made from high grade Alloy Steel
- Features a beech handle



SGS8 Gents Saw

Product Group	Discount Group
H881	C0602

- Perfect partner to the range of Hand and Tenon saws
- An Alloy Steel blade with brass back



SFFC Flexible Flush Cutting Saw

Product Group	Discount Group
H882	C0602

- Made from Flexible Alloy Steel
- Features a beech handle
- Cuts on the pull stroke
- Ideal for cutting dowels, etc



Part No.	Length	Points per inch	Barcode	Part No.	Length	Points per inch	Barcode
S52 - TENON SAW				S95248			
S528	8"	15	9314350011618	S95265 RIP	26"	8	9314350011687
S5210	10"	15	9314350013971	S95266	26"	5	9314657026391
S5212	12"	15	9314350013964	S95267	26"	6	9314350011700
S5214	14"	15	9314350011601	S95HANDLE	-	7	9314350011717
S52HANDLE	-	-	9314350011625	SDS819 DOVE TAIL SAW	-	-	9314350013988
S95 HAND SAW				SDS819	8"	20	9314350013995
S952010	20"	10	9314350011632	SGS8 GENTS SAW			
S95228	22"	8	9314350011656	SGS8	8"	20	9314350015975
S952210	22"	10	9314350011649	SFFC FLEXIBLE FLUSH CUTTING SAW			
S95246	24"	6	9314350011663	SFFC	6"	20	9314350015982
S95247	24"	7	9314350011670				

S25 Hand Saw

Product Group	Discount Group
H885	C0602

- These heat treated, hardpoint saws give prolonged life
- Hold thie edge up to 6x as long as standard teeth
- Supplied with soft touch handle



S12 Tenon Saw

Product Group	Discount Group
H886	C0602

- These heat treated, hardpoint saws give prolonged life
- Hold thie edge up to 6x as long as standard teeth
- Supplied with soft touch handle



SWB-6 Wallboard Saw

Product Group	Discount Group
H887	C0602

- 150mm cutting blade
- 320mm long
- Ergonomic rubberised handle and teeth sharpened on both sides
- For use with Plasterboard, plywood, etc



Coping Saw

Product Group	Discount Group
H888	C0602

- 170mm (6 3/4") Blade Length
- 125mm deep
- Includes 5 blades for a range of wood and metal cutting applications

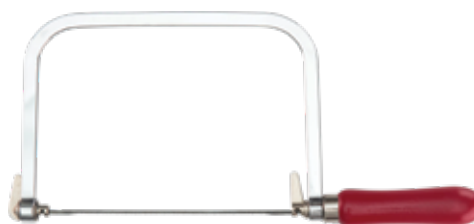

Fine Detail Saw

Product Group	Discount Group
H889	C0602

- Ideal for cutting dowels, dovetails and other precision work
- 178mm blade



Double Pull Saw

Product Group	Discount Group
H890	C0602

- Triple ground teeth
- 1 edge 9 P.P.I - 1 edge 15 P.P.I
- For trimming thin sections from the bottom of doors and door jambs



Part No.	Length	Points per inch	Barcode
S25 HAND SAW			
S25HP227	22" 560mm	7	9314350017115
S12 TENON SAW			
S12HP1212	12" 300mm	12	9314350017122
SWB-6 WALLBOARD SAW			
SWB-6	-	-	9314350021877
COPING SAW			
SCS55	-	-	9314350025943
FINE DETAIL SAW			
SFDS	-	-	9314350025950
DOUBLE PULL SAW			
SDPS300	-	-	9314350026100

ALL PURPOSE MAGIC SAWS

8 Piece - Medium Grip

Product Group	Discount Group
H893	C0602

- Contains: Frame, 6 coping saw blades, 1 straight saw blade for wood & plasterboard
- Includes glass cutting tip, and glass & tile breaking grip



7 Piece - Small Grip

Product Group	Discount Group
H894	C0602

- Contains: Frame, 5 coping saw blades, 1 straight saw blade for wood & plasterboard



Replacement Coping Saw Blades

Product Group	Discount Group
H895	C0602

- Contains: 5 replacement coping saw blades
- For both HA907 & HA 105



Replacement Wood Blades

Product Group	Discount Group
H897	C0602

- HA102 - Replacement Blade for HA105 Round Head 105 Round Head
- HA902 - Replacement Blade for HA907 Square Head



6" Magic Saw

Product Group	Discount Group
H896	C0602

- Cuts wood, aluminium, nails, bolts, plastic, rubber and stainless steel



Magic Saw Diamond Blade

Product Group	Discount Group
H890	C0602

- Cuts tile, ceramics, glass and metal



Part No.	Length	Points per inch	Barcode
8 PIECE MEDIUM GRIP			
HA 907	-	-	9314350018167
7 PIECE SMALL GRIP			
HA 105	-	-	9314350018174
REPLACEMENT COPING SAW BLADES			
HA 103-A	-	-	9314350018181
6" MAGIC SAW			
HA 500	-	-	9314350019461

Part No.	Length	Points per inch	Barcode
REPLACEMENT WOOD BLADES			
HA 102	-	-	9314350019492
MAGIC SAW DIAMOND BLADE			
HA-DIA-S	-	-	9314350019478



PLANER & BUZZER BLADES

- 155** CORRUGATED BACK KNIVES
- 154** ELECTRIC HAND PLANER BLADES
- 154** SOLID CARBIDE PLANER KNIVES
- 154** SOLID TUNGSTEN CARBIDE KNIVES
- 155** THIN PLANER/BUZZER BLADES

Electric Hand Planer Blades

- For electric hand planers

Product Group	Discount Group
J101	Z0930

Part No.	Machine	Models	Barcode
HIGH SPEED STEEL			
KH1900B	MAKITA	1100, 1900, 1900B, 1923	9314350002357
KHL120	RYOBI TOWA	L120, L120N	9314350002395
KHL22D	RYOBI TOWA	L22, L22D	9314350002371
KHL22L	RYOBI TOWA	L22L	9314350002388
KHF20A	HITACHI	PF2, PF3, FU20, F20A	9314350002364
KHF30A	HITACHI	F30A	9314350010246

Product Group	Discount Group
J100	Z0932

Part No.	Machine	Models	Barcode
CARBIDE TIPPED			
KT1900B	MAKITA	1100, 1900, 1900B, 1923	9314350002401
KTF20A	HITACHI	PF2, PF3, FU20, F20A	9314350002418
KTF30A	HITACHI	F30A	9314350010833
KTL22D	RYOBI TOWA	L22, L22D	9314350002425
KTL22L	RYOBI TOWA	L22L	9314350002432
KTL120	RYOBI TOWA	L120, L120N	9314350002449

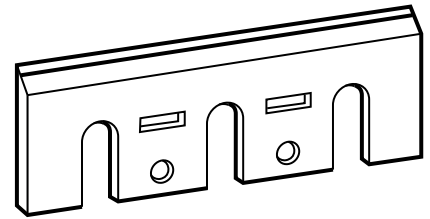

Solid Tungsten Carbide Knives

- Twin edge 82mm long
- For hand planers fitted with conversion sets
- Set of 2

Product Group	Discount Group
J107	Z0930

Part No.	Edge Length mm	Barcode
KTKNIVES	82	9314350007963

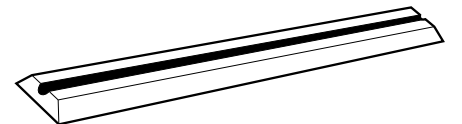

Solid Carbide Planer Knives

- Supplied in 2 or 3 piece sets
- Special sizes available upon request

Product Group	Discount Group
J106	Z0932

Part No.	Thickness		Width		Length		Barcode
	inch	mm	inch	mm	inch	mm	
KTSC 20	1/8	3.2	5/8	15.9	6	152.4	9314350010918
KTSC 24	1/8	3.2	3/4	19	6	152.4	9314350010925

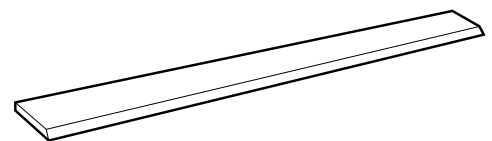

Thin Planer/Buzzer Blades

- Available in lengths up to 1060mm (HSS) and 1010mm (Carbide Tipped)
- Sets of any number can be matched and balanced
- HSS - 18% Tungsten

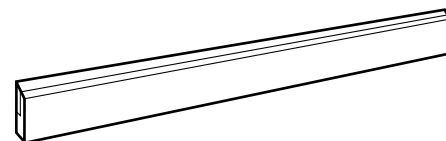

Product Group **Discount Group**
 J103 Z0932

Part No.	Thickness mm	Width mm	Barcode
HIGH SPEED STEEL			
KH3MMX20MM	3	20	9314350045538
KH3MMX25MM	3	25	9314350045545
KH3MMX30MM	3	30	9314350045552
KH3MMX35MM	3	35	9314350045569

Product Group **Discount Group**
 J102 Z0932

Part No.	Thickness mm	Width mm	Barcode
CARBIDE TIPPED			
KT3MMX20MM	3	20	9314350010840
KT3MMX22MM	3	22	9314350010857
KT3MMX25MM	3	25	9314350010864
KT3MMX30MM	3	30	9314350010871
KT3MMX35MM	3	35	9314350010888
KT3MMX38MM	3	38	9314350010895
KT4MMX38MM	4	38	9314350010901

Corrugated Back Knives

- Available in lengths up to 650mm
- HSS - 6-7% Tungsten

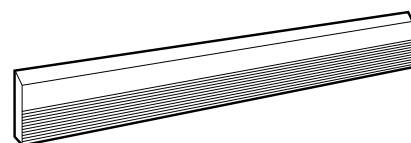

Product Group **Discount Group**
 J104 Z0932

Part No.	Thickness mm	Width mm	Barcode
HIGH SPEED STEEL			
KH8MMX40MM	8	40	9314350045576
KH8MMX50MM	8	50	9314350046597
KH8MMX60MM	8	60	9314350046606
KH8MMX70MM	8	70	9314350046620

Product Group **Discount Group**
 J105 Z0932

Part No.	Thickness mm	Width mm	Barcode
CARBIDE TIPPED			
KT10MMX60MM	10	60	9314350045644
KT10MMX70MM	10	70	9314350045651



ACCESSORIES

165	ADJUSTABLE CLAMP	162	LONG PUSH BLOCK
165	ADJUSTABLE MINI CORNER CLAMP	164	MITRE GAUGE
165	ADJUSTABLE PROFESSIONAL CORNER CLAMP	160	PVA WOOD WORKING GLUE
166	ALLEN KEYS	162	PUSH STICK
164	ALUMINIUM INSERT PLATE	165	REPLACEMENT CORNER PIECES
167	ARBORS	165	REPLACEMENT JAWS
166	BALL BEARINGS	160	ROUTER BASE PLATE ADAPTOR KIT
165	BAR CLAMP AND SPREADER	159	ROUTER DEPTH GAUGE
166	CARBI-SMOOTH BEARING ASSEMBLIES	164	ROUTER TABLE
167	COLLETS	164	ROUTER TABLE PACKAGE
158	CONTOUR GAUGE	162	SHARPENING STONES
158	CORNER CHISEL	163	SHORT PUSH BLOCK - OFFSET
161	DIAMOND POINTS	163	SHORT PUSH BLOCK - STRAIGHT
160	DRUM SANDING SET	159	STEP GAUGE
166	ECONOCUT BEARINGS	163	TABLE SAW MATE
163	FEATHERBOARD WITH ANGLE MEASURE	158	TEMPLATE GUIDE SET
		160	WOOD JOINING BISCUITS

Contour Gauge

- For use in woodworking and other applications where a profile needs to be cut or replicated
- Simply press contour gauge against the shape required then cut to shape
- Sturdy metal construction

Product Group	Discount Group
K102	Z0950

Part No.	Length	Barcode
CONG-152	-	9314350022744



Corner Chisel

- Ideal for squaring corners of routed cuts

Product Group	Discount Group
D827	Z0903

Part No.	Barcode
RCC-001	9314350012554



Template Guide Set

- 10 Piece Set
- Precision machined brass template guide
- Ideal for intricate detail, box joint and pattern work

Product Group	Discount Group
K104	Z0950

Part No.	Outside Diameter	Inside Diameter	Barrel Length	Barcode
TEGUK	5/16"	1/4"	5/32"	9314350026186
	3/8"	9/32"	5/16"	
	7/16"	11/32"	5/32"	
	1/2"	13/32"	5/16"	
	5/8"	17/32"	9/16"	
	3/4"	21/32"	9/16"	
	51/64"	5/8"	9/16"	
	1"	25/32"	3/8"	
	1 3/8"	19/32"	5/8"	
			Locknut	



Template Guide

- Additional template guides available separately (not included in kit)

Product Group	Discount Group
K105	Z0950

Part No.	Outside Diameter	Inside Diameter	Barrel Length	Barcode
TEGU5	1 1/4"	1 5/32"	1/2"	9314350026193
TEGU10	1 1/2"	1 13/32"	1/2"	9314350026209



Router Depth Gauge

- Simple and easy to use router depth gauge
- Reduces guess work and wasted timber
- Clearly marked in 15 steps from 1/8" up to 1"

Product Group	Discount Group
K106	Z0950
Part No.	Barcode
RDG-1	9314350022751



Step Gauge

- Makes accurate setups for table saws and radial arm saws

Product Group	Discount Group
K107	Z0950
Part No.	Barcode
SG-1	9314350022768

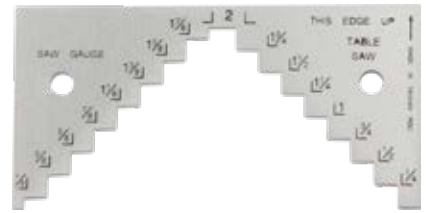

Router Base Plate Adaptor Kit

- Predrilled to fit most routers
- Made of clear plastic to allow the operator to see the templates when machining
- Includes plate, centering pin and screws

Product Group	Discount Group
K109	Z0950
Part No.	Barcode
BAPLK	9314350026216

*Brass guide not included.



Drum Sanding Set

- Includes 5 rubber backed drums: 1/2", 3/4", 1", 1 1/2", 2" diameter
- 2 x 80 grit sanding sleeves to suit each drum size (10 pieces)
- 2 x 120 grit sanding sleeves to suit each drum size (10 pieces)

Product Group	Discount Group	
K110	Z0104	
Part No.	Description	Barcode
DSK25	25 Pce. Drum Sanding Kit	9314350025905
DSKR80	Replacement Sanding Sleeve Pack 80 Grit (10 Pcs)	9314350046252
DSKR120	Replacement Sanding Sleeve Pack 120 Grit (10 Pcs)	9314350046269



PVA Wood Working Glue

- For all kinds of wood, card, craft and paper applications
- Bulk quantities available on request

Product Group	Discount Group	
K111	Z1006	
Part No.	Size	Barcode
PVA250	250ml	9314350025189
PVA500	500ml	9314350025172
PVA20L	20 Litres	9314350046290



Wood Joining Biscuits

- Compressed straight grained wood biscuits
- Expand on contact with water based glue
- Ideal for furniture, cabinets and other special woodworking applications

Product Group	Discount Group			
K112	Z1007			
Part No.	Quantity	Biscuit Size	For Joining	Barcode
BISC20 100	100 Pcs	0 (48 x 16 x 4mm)	8-12mm Timber	9314350025912
BISC10 125	125 Pcs	10 (54 x 19 x 4mm)	13-18mm Timber	9314350025929
BISCO 150	150 Pcs	20 (57 x 24 x 4mm)	19mm+ Timber	9314350025936



Diamond Points

- Ideal for carving and engraving on wood, ceramics, glass and other hard materials



DPS-10



DPS-20

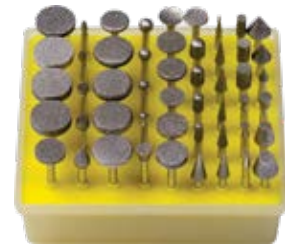

DPS-50

Product Group	Discount Group	
K113	Z0110	
Part No.	Contents	Barcode
DPS-10	Cylindricals, Ball, Cone, Taper, Pointed Cones	9314350022638
DPS-20	Cylindricals, Ball End Cylindrical, Balls, Pointed Cones, Flame, Inverted Taper	9314350022614
DPS-50	Cylindricals, Ball End Cylindricals, Cones, Inverted Cones, Pointed Cones, Flames, Balls, Tapers, Square Wheels, Radius Wheels	9314350022621

ACCESSORIES

Sharpening Stones

- Suitable for range of sharpening applications
- Can be used on knives, scissors, axes and other tools

Product Group	Discount Group	
K116	Z1402	
Part No.	Contents	Barcode
DWS-162	1 Double sided Whetstone 150mm x 50mm with handle	9314350022652
DWS-331	3 Whetstones (180, 260, 360 grit) each 76mm x 25mm	9314350022669

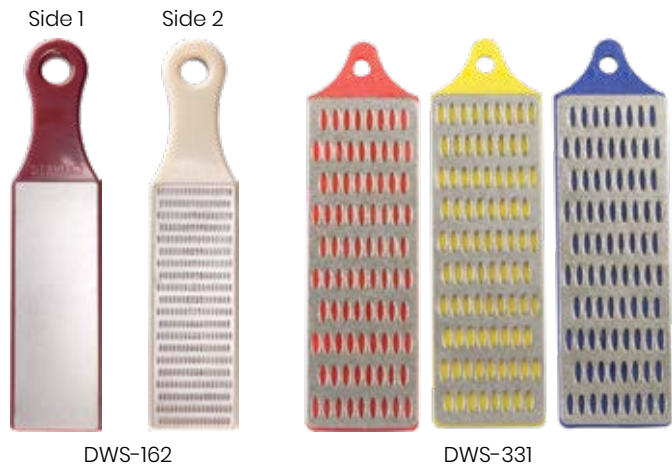

SAFETY AIDS

Push Stick

- 300mm long
- For use on router tables and sawbenches

Product Group	Discount Group
K133	Z1007
Part No.	Barcode
PS-1	9314350023581



Long Push Block

- 400mm long x 70mm wide
- Made of durable, strong shatter proof plastic
- Heavy duty rubber foam pad that will not mark the workplace

Product Group	Discount Group
K129	Z1007
Part No.	Barcode
PBL-1	9314350023536



Short Push Block – Straight

- 150mm long x 75mm wide
- Heavy duty rubber foam pads
- Comfortable straight handle

Product Group	Discount Group
K131	Z1007
Part No.	Barcode
PBSS-1	9314350023550



Short Push Block – Offset

- 150mm long x 75mm wide
- Heavy duty rubber foam pads
- Angled contoured handle for maximum grip and operator handle

Product Group	Discount Group
K130	Z1007
Part No.	Barcode
PBSO-1	9314350023567



Table Saw Mate

- 8 tools in 1: depth gauge, 230mm rule, 154mm hook rule, 90° square, 45° gauge for mitre cuts, 30° and 60° marks for setting up angles, centre finder, push stick

Product Group	Discount Group
K132	Z1007
Part No.	Barcode
SMT-1	9314350023843



Featherboard with Angle Measure

- Used to control passage of timber horizontally on router tables or vertically on the fence as a hold down
- Spirit level indicates exact angle of timber passage

Product Group	Discount Group
K128	Z1007
Part No.	Barcode
FAM-1	9314350023574



TABLE

Router Table

Product Group	Discount Group
K118	Z0950

- Sturdy, simple but durable router table
- Work top is made of MDF with melamine top
- 800 x 610mm table top
- 10mm thick acrylic insert
- 6mm thick x 100mm high alloy fence
- 25mm thick x 150mm high sub-fences

**Mitre Gauge**

Product Group	Discount Group
K119	Z0950

- Fits the Carbitool router table

**Router Table Package**

Product Group	Discount Group
K125	Z0950

- Includes Router Table (MROUTI) and Mitre Gauge (MMITI)

**Aluminium Insert Plate**

Product Group	Discount Group
K120	Z0950

- Alternative to the acrylic plate supplied with the router table or to fit a custom made table
- 1/4" thick aluminium insert plate provides a true flat surface and limits any plate sag that may be experienced with the use of heavy routers
- Supplied with levelling screws, 4 magnets, 3 insert rings with screws to suit and a steel starter pin to aid in the routing of curved pieces
- Premarked holes (not predrilled) to match popular routers



Part No.	Description	Barcode
MROUTI	Router Table	9314350025325
MMITI	Mitre Gauge	9314350025332
MRMI	Router Table Package	9314350025509
MALIP	Aluminium Insert Plate	9314350026124

Adjustable Clamp

Product Group	Discount Group
K121	Z1007

- General purpose clamp with 7 jaw angles for a capacity range up to 180mm
- Features a patented ratchet mechanism with quick release trigger
- For use on a variety of clamping applications



Bar Clamp and Spreader

Product Group	Discount Group
K122	Z1007

- 150mm clamp capacity
- 165-350mm spreading capacity
- Quick release handle



Adjustable Professional Corner Clamp

Product Group	Discount Group
K124	Z1007

- For use in making picture frames of any shape, gluing boxes together or gluing trims without nailing
- Comes with flexible jaw inserts to help hold odd shaped items
- Maximum size 900mm x 900mm (steel band)

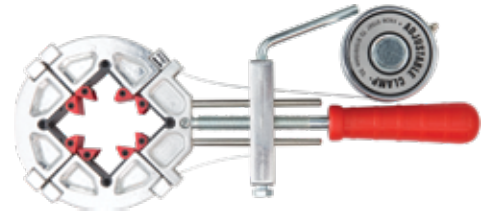

Replacement Corner Pieces

Product Group	Discount Group
K127	Z1007

- Extra jaws can be fitted to hold shapes with more than 4 corners, ie: Hexagonal, Octagonal etc
- Jaws can be removed to hold shapes with less than 4 corner ie triangles, D shapes, circles etc



Adjustable Mini Corner Clamp

Product Group	Discount Group
K123	Z1007

- Ideal for small picture frames
- Made of plastic with a web strap that allows for up to 1m x 1m clamping

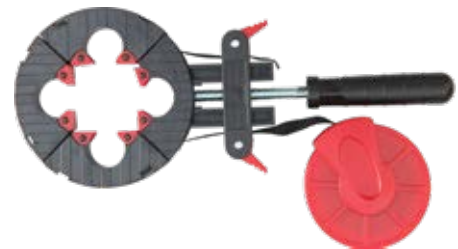

Replacement Jaws

Product Group	Discount Group
K126	Z1007

- Replacement jaws or flexible jaw inserts help hold those odd shaped items by allowing for angle



Part No.	Description	Barcode
CL180	Adjustable Clamp	9314350026223
CL150	Bar Clamp and Spreader	9314350025899
TV148	Adjustable Professional Corner Clamp	9314350014701
TVCP	Replacement Corner Pieces	9314350014725
TV149	Adjustable Mini Corner Clamp	9314350014695
TVFLEX	Replacement Jaws	9314350014718

Ball Bearings

Product Group **Discount Group**
R739 Z0904

Part No.	OD		ID		B		Barcode
	inch	mm	inch	mm	inch	mm	
TB2	3/8	9.5	1/4	6.35	1/8	3.2	9314350018556
TB3	-	28	5/16	8	23/64	9	9314350024298
TB4	3/4	19	1/2	12.7	5/32	4	9314350014077
TB5	3/4	19	-	6	-	6	9314350013957
TB6	1/4	6.35	1/8	3.2	7/64	2.7	9314350009585
TB7	1/2	12.7	1/4	6.35	3/16	4.8	9314350009479
TB8	5/8	15.9	3/16	4.8	3/16	4.8	9314350007635
TB9	3/8	9.5	3/16	4.8	1/8	3.2	9314350007642
TB10	3/8	9.5	1/8	3.2	5/32	4	9314350007659
TB11	1/2	12.7	3/16	4.8	3/16	4.8	9314350007666
TB12	0.866	22	5/16	8	0.275	6.9	9314350007673
TB13	0.945	24	5/16	8	5/16	8	9314350002081
TB14	5/8	15.9	1/4	6.35	3/16	4.8	9314350007680
TB15	13/16	20.6	1/4	6.35	19/64	7.6	9314350002098
TB16	3/4	19	1/4	6.35	9/32	7.1	9314350007697
TB17	1.102	28	0.472	12	5/16	8	9314350002104
TB18	1-1/8	28.6	1/2	12.7	5/16	8	9314350009578
TB19	3/4	19	5/16	8	-	6	9314350024304
TB20	-	24	-	15	-	5	9314350016866
TB21	-	35	-	15	-	11	9314350019614

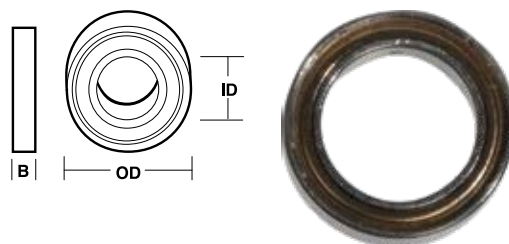

Note: All bearings should be kept free of dust and dirt. They should be cleaned in glue solvent and lightly oiled after each use

Econocut Bearings

Product Group **Discount Group**
R913 Z0905

Part No.	OD mm	ID mm	B mm	Barcode
EYB 1	16	5	5	9314350013728
EYB 2	9.5	3.2	4.8	9314350013735
EYB 3	9.5	4	3.2	9314350013742
EYB 4	12.7	4.8	4.8	9314350013759

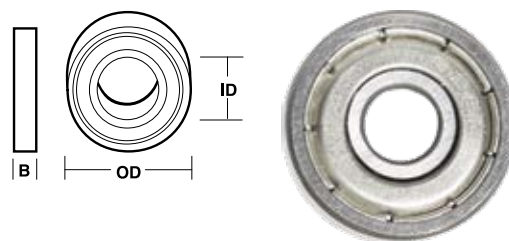

Carbi-Smooth Bearing Assemblies

Product Group **Discount Group**
R741 Z0904

Brg. Assembly No.	OD		ID		B		Barcode
	inch	mm	inch	mm	inch	mm	
TBT 19	3/4	19	1/4	19	15/64	6	9314350009356
TBT 20	5/8	15.9	1/4	15.9	15/64	6	9314350009363
TBT 21	3/4	19	1/4	19	15/64	6	9314350009370
TBT 22	7/8	22.2	1/4	22.2	15/64	6	9314350009387

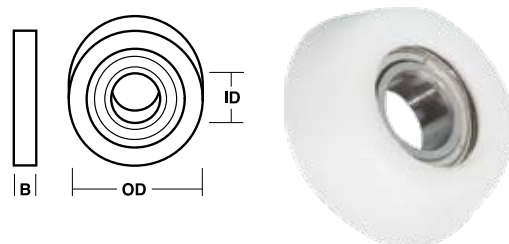

Note: TBT19 has bevelled smooth surface. All other bearings have a straight surface

Allen Keys

Product Group **Discount Group**
R930 Z0904

Part No.	Across Flats		Barcode
	inch	mm	
TK1	3/32	-	9314350002272
TK 2	5/32	-	9314350002289
TK3	-	1.5	9314350018587
TK4	-	2.0	9314350018594
TK5	-	2.5	9314350018600
TK6	-	3.0	9314350024328



Arbors

- Arbors available to suit all Carbitool arbor mounted router cutters, joining cutter, straight & bevel trim bits, slotting cutters etc

Product Group	Discount Group
R740	Z0924

Part No.	A1		A2		B		C		Barcode
	inch	mm	inch	mm	inch	mm	inch	mm	
TA1	1/4	6.35	0.315	8	7/8	22.2	2-3/8	60	9314350007703
TA3	1/2	12.7	0.315	8	7/8	22.2	2-5/8	67	9314350007710
TA4	1/4	6.35	0.315	8	0.76	19.3	2.26	57.4	9314350007727
TA5	1/2	12.7	0.315	8	0.76	19.3	2.51	63.7	9314350002173
TA6	1/2	12.7	0.315	8	1-1/4	31.8	3.1	78.7	9314350002180
TA7	1/2	12.7	1/2	12.7	0.95	24.1	3.1	78.7	9314350002197
TA9	1/4	6.35	1/4	6.35	1-1/8	28.8	2-3/8	60	9314350002203
TA10	1/4	6.35	0.295	7.5	5/8	15.9	2.062	52.4	9314350002210
TA13	1/4	6.35	0.315	8	1-1/2	38.1	3	76	9314350002227
TA19	1/2	12.7	0.315	8	1-29/64	37	3-5/16	84	9314350020399
TA20	1/2	12.7	0.315	8	1-25/69	50	4	101.6	9314350010659
TA21	1/2	12.7	1/2	12.7	1-3/4	44.4	3-5/8	92	9314350010666
TA23	1/2	12.7	5/8	16	2.07	52.5	3-25/32	96	9314350024915

Product Group	Discount Group
R743	Z0924

Part No.	A1		A2		B		C		Barcode
	inch	mm	inch	mm	inch	mm	inch	mm	
TA8	1/2	12.7	1/2	12.7	3/32	2.4	2.25	57.1	9314350002111
TA11	1/4	6.35	0.295	7.5	0.03	0.8	1.465	37.2	9314350002128
TA15	1/4	6.35	0.315	8	0.03	0.8	1-7/8	47	9314350002135
TA16	1/2	12.7	0.315	8	0.03	0.8	1.78	45.2	9314350002142
TA17	1/4	6.35	0.315	8	0.12	3	1.825	46.4	9314350002159
TA18	1/2	12.7	0.315	8	0.12	3	1.87	47.5	9314350002166
TA22	1/2	12.7	-	-	-	-	3-25/32	96	9314350024908
TA24	1/2	12.7	-	-	-	-	3-25/32	96	9314657026773
TA25	1/4	6.35	5/8	16	0.33	8.5	2-45/64	68.5	9314350025875
TA26	1/2	12.7	5/8	16	0.33	8.5	2-45/64	68.5	9314350025882

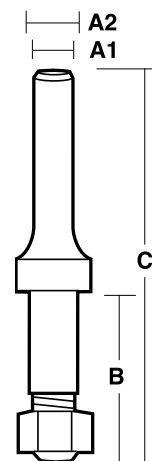

TA1

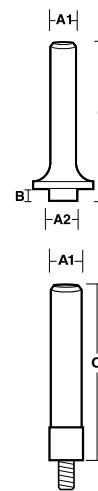

TA11

Collets

- TC3 suits Makita Trimmer model 3700B

Product Group	Discount Group
R744	Z1110

Brg. Assembly No.	OD		ID (Bore)		Style	Barcode
	inch	mm	inch	mm		
TC1	1/2	12.7	1/4	6.35	STRAIGHT	9314350002241
TC2	1/2	12.7	3/8	9.5	STRAIGHT	9314350002258
TC3	-	11	1/4	6.35	CONE	9314350002265
TC4	1/2	12.7	1/4	6.35	STEPPED	9314350019676
TCM2	1/4	6.35	-	2	STRAIGHT	9314350018563
TCM3	1/4	6.35	-	3	STRAIGHT	9314350018570
TCM4	1/4	6.35	-	4	STRAIGHT	9314350024274

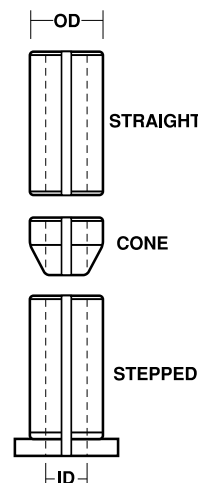

BAPLK	160
BISCO 150	160
BISCO10 125	160
BISCO20 100	160
CL150	165
CL180	165
CONG-152	158
DCS2.4	131
DCS3.2	131
DCS3.2 DS	130
DCS3.5 DS	130
DCS3.8 DS	130
DCS4.0	131
DCS4.0 DS	130
DCS4.4	131
DCS5.0	131
DCS5.0 DS	130
DCS5.0-16	131
DCS6.3	131
DCSRD2.4	131
DCSRD3.2	131
DCSRD3.2DS	130
DCSRD3.5DS	130
DCSRD3.8DS	130
DCSRD4.0	131
DCSRD4.0DS	130
DCSRD4.4	131
DCSRD5.0	131
DCSRD5.0DS	130
DCSRD6.3	131
DIACR 3.5 MB 1/2	116
DIACR 6 MB 1/2	116
DIACR 10 MB 1/2	116
DIACR 12 MB 1/2	116
DIACR 45 B 1/2	116
DIACR 135 B 1/2	116
DIACR 12730 B	117
DIACR 12730 B 1/2	117
DIAT RO 6MR 16	121
DIAT RO 10MR 16	121
DIAT RO 12MR 16	121
DIAT VGC 45D 16	121
DIAT WD 5 L 57	122
DIAT WD 5 L 70	122
DIAT WD 5 R 57	122
DIAT WD 5 R 70	122
DIAT WD 6 L 57	122
DIAT WD 6 L 70	122
DIAT WD 6 R 57	122
DIAT WD 6 R 70	122
DIAT WD 8 L 57	122
DIAT WD 8 L 70	122
DIAT WD 8 R 57	122
DIAT WD 8 R 70	122
DIAT WD 10 L 57	122
DIAT WD 10 L 70	122
DIAT WD 10 R 57	122
DIAT WD 10 R 70	122
DIAT WD 15 L 57	122
DIAT WD 15 R 57	122
DIAT WD 30 L 57	122
DIAT WD 30 L 70	122
DIAT WD 30 R 57	122
DIAT WD 30 R 70	122
DIAT WD 35 L 57	122
DIAT WD 35 L 70	122
DIAT WD 35 R 57	122
DIAT WD 35 R 70	122
DIAT WD 40 L 57	122
DIAT WD 40 L 70	122
DIAT WD 40 R 57	122
DIAT WD 40 R 70	122
DIAT WDT 5 L 57	123
DIAT WDT 5 L 70	123

DIAT WDT 5 R 57	123
DIAT WDT 5 R 70	123
DIAT WDT 6 L 57	123
DIAT WDT 6 L 70	123
DIAT WDT 6 R 57	123
DIAT WDT 6 R 70	123
DIAT WDT 8 L 57	123
DIAT WDT 8 L 70	123
DIAT WDT 8 R 57	123
DIAT WDT 8 R 70	123
DIAT WDT 10 L 57	123
DIAT WDT 10 L 70	123
DIAT WDT 10 R 57	123
DIAT WDT 10 R 70	123
DIATL 10M 12	118
DIATL 12M 12	118
DIATL 12M 25	118
DIATL 14M 16	118
DIATL 16M 16	118
DIATL 16M 20	118
DIATL 18M 16	118
DIATL 18M 20	118
DIATL 18M 25	118
DIATL 20M 20	118
DIATL 20M 25	118
DIATL HP 18M 20	119
DIATL HP 18M 25	119
DIATL HP 20M 20	119
DIATL HP 20M 25	119
DIATL S 6M 12	119
DIATL S 8M 12	119
DIATL S 10M 12	119
DIATL S 12M 12	119
DIATL S 16M 16	119
DIATL SX 10M 12	119
DIATL SXE 16M 16	119
DIATL XE 12M 12	118
DIATL XE 16M 16	118
DIATL XE 16M 20	118
DIATL XE 18M 20	118
DIATL XE 18M 25	118
DIATL XE 20M 20	118
DIATL XE 20M 25	118
DIATL XE XP 20M 25	120
DIATL XE XP 25M 25	120
DIATL XEHP 18M 20	119
DIATL XEHP 18M 25	119
DIATL XEHP 20M 20	119
DIATL XEHP 20M 25	119
DIATL XP 20M 20	120
DIATL XP 20M 25	120
DIATL XP 25M 20	120
DIATL XP 25M 25	120
DIATL XXE 16M 16	118
DIATL XXE 16M 20	118
DIATL XXE 18M 20	118
DIATL XXE 18M 25	118
DIATL XXE 20M 20	118
DIATL XXE 20M 25	118
DIATL XXE XP 25M 25	120
DIATR 10M 12	118
DIATR 12M 12	118
DIATR 12M 25	118
DIATR 14M 16	118
DIATR 16M 16	118
DIATR 16M 20	118
DIATR 18M 16	118
DIATR 18M 20	118

DIATR 18M 25	118
DIATR 20M 20	118
DIATR 20M 25	118
DIATR HP 18M 20	119
DIATR HP 18M 25	119
DIATR HP 20M 20	119
DIATR HP 20M 25	119
DIATR S 6M 12	119
DIATR S 8M 12	119
DIATR S 10M 12	119
DIATR S 12M 12	119
DIATR S 16M 16	119
DIATR S 8012 B	26
DIATR S 8012 B	120
DIATR S 8016 B	26
DIATR S 8016 B	120
DIATR S 8016 B 1/2	26
DIATR S 8016 B 1/2	120
DIATR SX 10M 12	119
DIATR SXE 16M 16	119
DIATR XE 12M 12	118
DIATR XE 16M 16	118
DIATR XE 16M 20	118
DIATR XE 18M 16	118
DIATR XE 18M 20	118
DIATR XE 18M 25	118
DIATR XE 20M 20	118
DIATR XE 20M 25	118
DIATR XE XP 20M 25	120
DIATR XE XP 25M 25	120
DIATR XEHP 18M 20	119
DIATR XEHP 18M 25	119
DIATR XEHP 20M 20	119
DIATR XEHP 20M 25	119
DIATR XP 20M 20	120
DIATR XP 20M 25	120
DIATR XP 25M 20	120
DIATR XP 25M 25	120
DIATR XXE 16M 16	118
DIATR XXE 16M 20	118
DIATR XXE 18M 20	118
DIATR XXE 18M 25	118
DIATR XXE 20M 20	118
DIATR XXE 20M 25	118
DIATR XXE XP 25M 25	120
DIATR XXEHP 20M 20	119
DIATR XXEHP 20MM 25	119
DIATR XXXE 20M 20	118
DIATR XXXE 20M 25	118
DIATR XXXE XP 25M 25	120
DPS-10	161
DPS-20	161
DPS-50	161
DSCR 125	147
DSCR 180	147
DSCR 230	147
DSK25	160
DSKR80	160
DSKR120	160
DSLW 105	147
DSLW 125	147
DSLW 180	147
DSLW 230	147
DSLW 350	147
DST3M	133
DST4M	133
DST6M	133
DST8M	133
DST10M	133
DST12M	133
DST 368M KIT	133
DSTR 105	147
DSTR 125	147
DSTR 180	147

DSTR 230	147
DWS-162	162
DWS-331	162
EXPDB-1	135
EXPDB-2	135
EY 112	99
EY 112 1/2	99
EY 206 M	98
EY 208 M	98
EY 210 M	98
EY 212 M	98
EY 213 M	98
EY 216 M	98
EY 218 M	98
EY 219 M	98
EY 416	100
EY 416 1/2	100
EY 420	100
EY 420 1/2	100
EY 424	100
EY 424 1/2	100
EY 508 B	100
EY 508 B 1/2	100
EY 510 B	100
EY 510 B 1/2	100
EY 512 B	100
EY 512 B 1/2	100
EY 516 B	100
EY 516 B 1/2	100
EY 608 B	101
EY 608 B 1/2	101
EY 610 B	101
EY 610 B 1/2	101
EY 612 B	101
EY 612 B 1/2	101
EY 616 B	101
EY 616 B 1/2	101
EY 708 B	101
EY 708 B 1/2	101
EY 712 B	101
EY 712 B 1/2	101
EY 716 B	101
EY 716 B 1/2	101
EY 916 B	102
EY 916 B 1/2	102
EY 1018	98
EY 1018 1/2	98
EY 1406 M	98
EY 1408 M	98
EY 1410 M	98
EY 1412 M	98
EY 1413 M	98
EY 1416 M	98
EY 1418 M	98
EY 1419 M	98
EY 1708 B	102
EY 1708 B 1/2	102
EY 1712 B	102
EY 1712 B 1/2	102
EY 5705 B	99
EY 5705 B 1/2	99
EY 5708 B	99
EY 5708 B 1/2	99
EY 7506 B	99
EY 7506 B 1/2	99
EY 7508 B	99
EY 7508 B 1/2	99
EY 8012 B	100
EY 8012 B 1/2	100
EY 8016 B	100
EY 8016 B 1/2	100
EY 8020 B	100
EY 8020 B 1/2	100
EYB1	166

EYB 2	166
EYB 3	166
EYB 4	166
EYC 8 B	101
EYC 8 B 1/2	101
EYC 12 B	101
EYC 12 B 1/2	101
FAM-1	163
FB 06M	134
FB 08	134
FB 10M	134
FB 12	134
FB 12M	134
FB 16	134
FB 16M	134
FB 20	134
FB 20M	134
FB 22M	134
FB 24	134
FB 25M	134
FB 28	134
FB 28M	134
FB 32	134
FB 32M	134
FB 35M	134
FB 36	134
FB 38M	134
FB 40	134
FB 42M	134
FB 44	134
FB 45M	134
FB 48	134
FB 48M	134
FB 50M	134
FB 52	134
FB 54M	134
FB 56	134
FB 60	134
FB 64	134
FB 72	134
FB-5KIT TCT METRIC	134
FBT 06M	134
FBT 10M	134
FBT 12M	134
FBT 16M	134
FBT 20M	134
FBT 22M	134
FBT 25M	134
FBT 28M	134
FBT 32M	134
FBT 35M	134
FBT 38M	134
FBT 42M	134
FBT 45M	134
FBT 48M	134
FBT 50M	134
FBT 54M	134
H 112	40
H 204 MS	15
H 204 S	15
H 205 S	15
H 208	15
H 208 S	15
H 210	15
H 212	15
H 213 M	15
H 214	15
H 216	15
H 216 M	15
H 219 M	15
H 220	15
H 224	15
H 304	41
H 408	42

H 412	42
H 416	42
H 420	42
H 424	42
H 510	51
H 512	51
H 516	51
H 604	53
H 608	53
H 612	53
H 708	55
H 712	55
H 716	55
H 916	59
H 1012	35
H 1018	35
H 1018 1/2	35
H 1416	15
H 1508	23
H 1512 3/8	23
H 1516 1/2	23
H 1708	62
H 1712	62
H 2016	21
H 5705	65
H 5708	65
H 7506	44
H 7509	44
HA 102	152
HA 103-A	152
HA 105	152
HA 500	152
HA 902	152
HA 907	152
HA-DIA-S	152
HDSC-1	131
HDSC-2	131
HDSC-3	131
HDSC-4	131
HDSC-5	131
HMC08	132
HMC10	132
HMC12	132
HMC14	132
HMC16	132
HMC18	132
HMC20	132
HMC24	132
HMC28	132
HMC32	132
HPLG 08	136
HPLG 12	136
HPLG 16	136
HPLG 20	136
HSD-3 KIT 1	136
HSF 1508	24
HSF 1512 3/8	24
HSF 1516 1/2	24
HX 208	15
JD250X2.5X32X180	148
JD250X2.5X32X200	148
JD250X2.5X32X220	148
JD250X2.5X40X220	148
JD250X2X32X180	148
JD250X2X32X200	148
JD250X2X32X220	148
JD275X2.5X32X180	148
JD275X2.5X32X220	148
JD275X2.5X40X180	148
JD275X2.5X40X220	148
JD300X2.5X32	149
JD300X2.5X32X200	148
JD300X2.5X32X220	148
JD300X2.5X38	149

JD300X2.5X38X220	148
JD300X2.5X38X280	148
JD300X2.5X40	149
JD300X2.5X40X160	148
JD300X2.5X40X180	148
JD300X2.5X40X200	148
JD300X2.5X40X220	148
JD300X2.5X40X240	148
JD315X2.5X32	149
JD315X2.5X32X180	148
JD315X2.5X32X200	148
JD315X2.5X32X220	148
JD315X2.5X32X240	148
JD315X2.5X32X260	148
JD315X2.5X40	149
JD315X2.5X40X180	148
JD315X2.5X40X200	148
JD315X2.5X40X220	148
JD315X2.5X40X240	148
JD350X2.5X32	149
JD350X2.5X32X180	149
JD350X2.5X32X200	149
JD350X2.5X32X220	149
JD350X2.5X32X240	149
JD350X2.5X40	149
JD350X2.5X40X160	149
JD350X2.5X40X180	149
JD350X2.5X40X200	149
JD350X2.5X40X220	149
JD350X2.5X40X240	149
KH3MMX20MM	155
KH3MMX25MM	155
KH3MMX30MM	155
KH3MMX35MM	155
KH8MMX40MM	155
KH8MMX50MM	155
KH8MMX60MM	155
KH8MMX70MM	155
KH1900B	154
KHF20A	154
KHF30A	154
KHL22D	154
KHL22L	154
KHL120	154
KT3MMX20MM	155
KT3MMX22MM	155
KT3MMX25MM	155
KT3MMX30MM	155
KT3MMX35MM	155
KT3MMX38MM	155
KT4MMX38MM	155
KTI0MMX60MM	155
KTI0MMX70MM	155
KTI900B	154
KTF20A	154
KTF30A	154
KTKNIVES	154
KTL22D	154
KTL22L	154
KTL120	154
KTSC 20	154
KTSC 24	154
L5BA10N 150	142
L5BA10N 180	142
L5BA10N 250	142
L5BA10T3 180	142
L5BA10T3 250	142
L5BA10T3 300	142
L5BA14N 225	142
L5BA14N 250	142
L5BA14N 300	142
L5BA16N 380	144
L10BA19N 250	143
L10BA19N 300	143

L10BA30N 250	143
L10BA30N 300	143
L10BA30N 350	143
L10BA30N 380	144
L10BA30N 400	143
L10BA30N 450	143
L10BA30N 500	143
L20BA19N 250	143
L20BA19N 300	143
L20BA19N 350	143
L20BA19N 400	143
L20BA19N 450	143
L20BA30N 250	144
L20BA30N 300	144
L20BA30N 350	144
L20BA30N 400	144
L20BA30N 500	144
L20BA39N 250	144
L20BA39N 300	144
L20BA39N 350	144
L20BA39N 450	144
L20BA39N 560	144
L20BA39N 610	144
LN2BA30N 300	144
LN2BA30N 350	144
LN2BA30N 400	144
LN2EAM10 180	145
LN2EAM10 200	145
LN2EAM10 250	145
LN2EAM10 275	145
LN2EAM10 300	145
LN2EAM10 350	145
LN2EAM10 400	145
LN2EAM10 450	145
LN2EAM14 300	145
LN2EAM14 400	145
LPQ5BA10N 300	142
LPQ5BA14N 250	142
LPQ5BA14N 300	146
LPQ5BA14N 350	142
LPQ5EA10N 300	143
LPQ5EA14N 300	143
LPQPKGBA72-20	146
LPQPKGBA72-22	146
LPQPKGBA96-20	146
LPQPKGBA96-22	146
LPQPKGEA72-20	146
LPQPKGEA72-22	146
LPQPKGEA96-20	146
LPQPKGEA96-22	146
LPQSPLIT 100X20	145
LPQSPLIT 120X20	145
LPQSPLIT 120X22	145
LPQSPLIT 125X20	145
LSOLID 120X20	145
LSPLIT 100X20	145
LSPLIT 100X22	145
LSPLIT 120X20	145
M3	114
M3.5	114
M4	114
M4	114
M6 24T 5/8	140
M6 24T 20MM	140
M6 30T 20MM	140
M7 40T 20MM	140
M8 24T 25MM	140
M8 24T 30MM	140
M8 30T 25MM	140
M8 30T 30MM	140
M8 40T 25MM	140
M8 40T 30MM	140
M8 60T 25MM	140
M8 60T 30MM	140

M9 24T 13/8	140
M9 24T 25MM	140
M9 24T 30MM	140
M9 30T 5/8	140
M9 30T 13/8	140
M9 30T 25MM	140
M9 30T 30MM	140
M9 40T 13/8	140
M9 40T 25MM	140
M9 40T 30MM	140
M9 60T 13/8	140
M9 60T 25MM	140
M9 60T 30MM	140
M10 40T 5/8	140
M10 40T 25MM	140
M10 40T 30MM	140
M10 60T 5/8	140
M10 60T 25MM	140
M10 60T 30MM	140
M10 72T 5/8	140
M10 72T 25MM	140
M10 72T 30MM	140
M12 30T 30MM	140
M12 72T 11/4	140
M12 72T 25MM	140
M12 72T 30MM	140
M184 20T 20MM	140
M184 30T 20MM	140
M184 40T 20MM	140
M210 24T 25MM	140
M210 24T 30MM	140
M210 30T 25MM	140
M210 30T 30MM	140
M210 40T 25MM	140
M210 40T 30MM	140
M210 60T 20MM	140
M210 60T 25MM	140
M210 60T 30MM	140
M262 60T 1	140
M-THIN6 24T 20MM	141
M-THIN6 40T 20MM	141
M-THIN184 20T 20MM	141
M-THIN184 30T 20MM	141
M-THIN184 40T 20MM	141
M-THIN210 30T 25MM	141
M-THIN210 40T 25MM	141
M-THIN235 30T 25MM	141
M-THIN235 40T 25MM	141
M-THIN250 100T 30MM	141
M-THIN305 60T 1	141
M-THIN305 80T 1	141
MALIP	164
MMET102 20T 5/8	141
MMET115 20T 7/8	141
MMET125 20T 7/8	141
MMET150 30T 7/8	141
MMET150 30T 20MM	141
MMET184 36T 7/8	141
MMET184 36T 20MM	141
MMET185 48T 20MM	141
MMET185 48T 20MM	142
MMET210 40T 7/8	141
MMET210 40T 25MM	141
MMET230 48T 7/8	141
MMET230 48T 25MM	141
MMET250 60T 25MM	141
MMET305 60T 1	141
MMET305 60T 25MM	141
MMIT1	164
MN216 24T 30MM	141
MN216 48T 30MM	141
MNF9 80T 25MM	141
MNF10 80T 30MM	141
MNF10 100T 25MM	141

MNF10 100T 30MM	141
MNF160 60T 20MM	141
MNF184 60T 20MM	141
MNF210 80T 25MM	141
MNF216 60T 30MM	141
MNF216 80T 30MM	141
MNF262 80T 1	141
MNF300 100T 1	141
MNF300 100T 30MM	141
MPCD125 4T 20MM	142
MPCD160 4T 20MM	142
MPCD180 4T 20MM	142
MPCD250 6T 30MM	142
MPCD300 8T 30MM	142
MRMI	164
MROUT1	164
PBL-1	162
PBSO-1	163
PBSS-1	163
PL 7.65 12 1.5	113
PL 9.0 12 1.5	113
PL 12 12 1.5	113
PL 14 14 1.5	113
PL 14 14 2	113
PL 15 12 1.5	113
PL 19.5 12 1.5 E/C	113
PL 20 12 1.5	113
PL 25 12 1.5	113
PL 29.5 9 1.5 EC	114
PL 29.5 12 1.5 E/C	114
PL 30 12 1.5	113
PL 39.5 9 1.5 E/C	114
PL 39.5 12 1.5 EC	114
PL 40 12 1.5	113
PL 49.5 12 1.5 EC	114
PL 50 12 1.5	113
PL 50 12 1.7 E/C	114
PL 59.5 12 1.5 EC	114
PL 60 12 1.5	113
PLR 20 12	114
PLS 18	114
PLT 22	114
PS-1	162
PVA20L	160
PVA250	160
PVA500	160
R3 5512 1/2	110
R4 8012 16	110
R4 8012 20	110
R 22 B	109
R 22 B 1/2	109
R 45 B	109
R 45 B 1/2	109
R 1830 1/2	106
R 1830 16	106
R 1840 1/2	106
R 1850 1/2 - 3	106
R 1912	106
R 1912 1/2	106
R 1912 B	106
R 1912 B 1/2	106
R 1912 BB	107
R 1912 BB 1/2	107
R 1930 1/2	106
R 1930 16	106
R 1930 B 1/2	107
R 1930 BB 1/2	107
R 1940 1/2	106
R 1940 B 1/2	107
R 1940 BB 1/2	107
R 1950 1/2-3	106
R 1950 16-3	106
R 1950 B 1/2 - 3	107
R 2030 1/2	106

R 2030 16	106
R 2040 1/2	106
R 2040 16	106
RCC-001	158
RDG-1	159
REPD-2.4MM	131
REPD-2MM	131
REPD-3.5MM	131
REPD-3.175MM	131
REPD-3MM	131
RMS 200 1/2	111
RMS 300 1/2	112
RMS 300 16	112
RMST 201	111
RMST 202	111
RMST 203	111
RMST 204	111
RMST 205	111
RMST 206	111
RMST 207	111
RMST 301	112
RMST 302	112
RMST 303	112
RMST 304	112
RMSTB 20122	111
RMSTB 30202	112
RS 12.7 30 1/2	108
RS 1230 1/2	108
RS 1630 1/2	108
RS 1640 1/2	108
RS 1930 1/2*	108
RS 1940 1/2*	108
RS 1940 16*	108
RS 2030 1/2*	108
RS 2040 1/2*	108
RS 2040 16*	108
RSP 12.730 1/2*	108
RSP 1640 1/2*	108
RV 1930 B 1/2	108
RV 1940 B 1/2	108
RV 1950 B 1/2 - 3	108
RV 2440 B 1/2	108
RV 2450 B 1/2 - 3	108
RV 2830 B 1/2	108
RV 2840 B 1/2	108
RV 2850 B 1/2 - 2	108
RVG 90 1/2	109
RVG 91 1/2	109
S12HP1212	151
S25HP227	151
S52HANDLE	150
S95HANDLE	150
S528	150
S5210	150
S5212	150
S5214	150
S95228	150
S95246	150
S95247	150
S95248	150
S95265 RIP	150
S95266	150
S95267	150
S952010	150
S952210	150
SCS55	151
SDPS300	151
SDS819	150
SFDS	151
SFFC	150
SG-1	159
SGS8	150
SMT-1	163
SWB-6	151

T2ESRM08	12
T2ESRM8M	12
T2ESRM10M	12
T2ESRM12 3/8	12
T2SRM08 Q	12
T2SRM8M Q	12
T2SRM10M Q	12
T2SRM12 3/8 Q	12
T2SRM16 1/2	12
T2SRM16 1/2 Q	12
T2XESRM16 1/2 Q	12
T2XSRM16 1/2	12
T3ESRM10M	12
T3ESRM12 3/8	12
T3ESRM12 12M	12
T3SLW8	11
T3SLW 12 3/8	11
T3SLW 16 1/2	11
T3SRM10M Q	13
T3SRM12 3/8 Q	13
T3SRM16 1/2	12
T3SRM16 1/2 Q	13
T3SRW8	11
T3SRW12 3/8	11
T3SRW16 1/2	11
T3XESRM16 1/2 Q	13
T3XSRM16 1/2	12
T4SLRF12 3/8	9
T4SLRF 16 1/2	9
T4SRM16 1/2	13
T4SRM16 1/2 Q	13
T4SRMR10M Q	13
T4SRMR16 1/2	13
T4SRRF12 3/8	9
T4SRRF 16 1/2	9
T4XESRM16 1/2 Q	13
T4XESRMR16 1/2	13
T4XSLRF 16 1/2	9
T4XSRM16 1/2	13
T4XSRMR16 1/2	13
T4XSRRF 16 1/2	9
T10	114
T15	114
T 100	34
T 112	40
T 112 W/F	40
T 128	40
T 128 1/2	40
T 128 1/2 W/F	40
T 128 W/F	40
T 192.00 B	29
T 192.22 B	29
T 192.30 B	29
T 193.00	29
T 194-3 M LH	69
T 194-3 M RH	69
T 194-5 M LH	69
T 194-5 M RH	69
T 194-8 M LH	69
T 194-8 M RH	69
T 194.00	30
T 194.15	30
T 194.15 LH	31
T 194.25	30
T 194.25 LH	31
T 194.45	30
T 194.45 LH	31
T 202 MS	16
T 202 S	16
T 203 MS	16
T 203 S	16
T 204 MS	16
T 204 S	16
T 205 MS	16

*These tools will be deleted from the range once current stocks are sold out.

T 205 S	16
T 206 M	16
T 206 MS	16
T 206 S	16
T 207 M	17
T 207 S	16
T 208	16
T 208 M	17
T 208 S	16
T 209	17
T 209 M	17
T 210	17
T 210 M	17
T 211 M	17
T 212	17
T 212 M	17
T 213 M	17
T 214	17
T 214 M	17
T 215 M	17
T 216	17
T 216 M	17
T 216.5 M	17
T 217 M	17
T 218	17
T 218 M	17
T 218.5 M	17
T 219 M	17
T 219.5 M	17
T 220	17
T 220 M	17
T 221 M	17
T 222	17
T 222 M	17
T 224	17
T 225 M	17
T 226	17
T 228	17
T 232	17
T 302	41
T 303	41
T 303 - 500	32
T 304	41
T 305	41
T 306	41
T 307	41
T 403 - 501	31
T 408	42
T 410	42
T 412	42
T 416	42
T 416 1/2	42
T 420	42
T 420 1/2	42
T 424	42
T 424 1/2	42
T 432 1/2	42
T 440 1/2	42
T 448 1/2	42
T 500-1.6M	93
T 500-2.5M	93
T 500-2.8M	93
T 500-2M	93
T 500-3.2M	93
T 500-3.6M	93
T 500-4.8M	93
T 500-4M	93
T 500-5.5M	93
T 500-6.4M	93
T 500-8.0M	93
T 502 B	52
T 502 MB	52
T 503 - 502	41
T 503 - 503	41

T 503 - 504	41
T 503 - 505	41
T 504 B	52
T 504 MB	52
T 505 MB	52
T 506	51
T 506 B	52
T 506 B 1/2	52
T 506 MB	52
T 508	51
T 508 B	52
T 508 B 1/2	52
T 510	51
T 510 B	52
T 510 B 1/2	52
T 510 MB 1/2	52
T 512	51
T 512 B	52
T 512 B 1/2	52
T 512 MB 1/2	52
T 516	51
T 516 B	52
T 516 B 1/2	52
T 520 B 1/2	52
T 524 B 1/2	52
T 528 B 1/2	52
T 532 B 1/2	52
T 540 B 1/2	52
T 602 B	53
T 602 MB	53
T 604	53
T 604 B	53
T 604 MB	53
T 605 MB	53
T 606 B	53
T 606 B 1/2	53
T 606 MB	53
T 608	53
T 608 B	53
T 608 B 1/2	53
T 610 B	53
T 610 B 1/2	53
T 610 MB 1/2	53
T 612	53
T 612 B	53
T 612 B 1/2	53
T 612 MB 1/2	53
T 616 B	53
T 616 B 1/2	53
T 620 B 1/2	53
T 624 B 1/2	53
T 628 B 1/2	53
T 632 B 1/2	53
T 640 B 1/2	53
T 700-1.6 M	95
T 700-2 M	95
T 700-2.5 M	95
T 700-2.8 M	95
T 700-3.2 M	95
T 700-3.6 M	95
T 700-4 M	95
T 700-4.8 M	95
T 700-5.5 M	95
T 700-6.4 M	95
T 700-8.0 M	95
T 702 B	56
T 703 - 507	31
T 704 B	56
T 706	55
T 706 B	56
T 708	55
T 708 B	56
T 708 B 1/2	56
T 710 B	56

T 710 B 1/2	56
T 712	55
T 712 B	56
T 712 B 1/2	56
T 716	55
T 716 B	56
T 716 B 1/2	56
T 720 B 1/2	56
T 724 B 1/2	56
T 803 - 509	20
T 900-1.2 M	25
T 900-1.6 M	25
T 916	59
T 916 B	60
T 916 B 1/2	60
T 920 B 1/2	60
T 924 B 1/2	60
T 1012	35
T 1016	35
T 1018	35
T 1018 1/2	35
T 1018 3/8	35
T 1018 10MM	35
T 1019	35
T 1024 1/2	35
T 1230 1/2	40
T 1236 1/2	40
T 1240 1/2	40
T 1406 M	18
T 1408	18
T 1408 M	18
T 1409 M	18
T 1410	18
T 1410 M	18
T 1410 M E/C	19
T 1410 MS	17
T 1411 M	18
T 1412	18
T 1412 M	18
T 1413 M	18
T 1413 M E/C	19
T 1413 MS	17
T 1414	18
T 1414 M	18
T 1415 M	18
T 1416	18
T 1416 M	18
T 1416 M E/C	19
T 1416 MS	17
T 1416.5 M	18
T 1417 M	18
T 1418	18
T 1418 M	18
T 1418 M E/C	19
T 1418.5 M	18
T 1419 M	18
T 1419 M E/C	19
T 1419.5 M	18
T 1420	18
T 1420 M	18
T 1422	18
T 1424	18
T 1425 M	19
T 1425 M E/C	19
T 1426	18
T 1428	18
T 1432	19
T 1432 M	19
T 1432 M EC	19
T 1435 M	19
T 1436	19
T 1448	19
T 1452	19
T 1456	19

T 1460	19
T 1464	19
T 1508	23
T 1510	24
T 1510 - 2	24
T 1512 3/8	24
T 1516 1/2	24
T 1622 1/2	21
T 1624 1/2	21
T 1626 1/2	21
T 1628 1/2	21
T 1708	62
T 1708 B	62
T 1708 B 1/2	62
T 1712	62
T 1712 B	62
T 1712 B 1/2	62
T 1716 B 1/2	62
T 1720 B 1/2	62
T 1804 MS	16
T 1804 S	16
T 1805 MS	16
T 1806 MS	16
T 1806 S	16
T 1808 S	16
T 1910	23
T 1910 - 2	23
T 2016	21
T 2614	32
T 2622	33
T 5705	65
T 5705 B	66
T 5705 B 1/2	66
T 5708	65
T 5708 B	66
T 5708 B 1/2	66
T 5712 B 1/2	66
T 6128	39
T 6128 1/2	39
T 7502	44
T 7502 1/2	44
T 7504	44
T 7504 1/2	44
T 7506	44
T 7506 1/2	44
T 7506 B	67
T 7506 B 1/2	67
T 7508 B	67
T 7508 B 1/2	67
T 7509	44
T 7509 1/2	44
T 7512 B 1/2	67
T 8008 B	26
T 8012 B	26
T 8012 BB	27
T 8016 B	26
T 8016 B 1/2	26
T 8016 BB	27
T 8016 BB 1/2	27
T 8020 B	26
T 8020 B 1/2	26
T 8020 BB	27
T 8020 BB 1/2	27
T 8028 B 1/2	26
T 8028 BB 1/2	27
T 8105 B 1/2	60
T 8110 B 1/2	60
T 8122 B	60
T 8122 B 1/2	60
T 8130 B	60
T 8130 B 1/2	60
T 8165 B	61
T 8165 B 1/2	61
T 8180 B	61

T 8180 B 1/2	61
T 8212 B	28
T 8216 B	28
T 8216 DB	27
T 8220 B	28
T 8224 B 1/2	28
T 8224 DB 1/2	27
T 8236 B 1/2	28
T 9122 B	29
T 9130 B	29
TA1	167
TA3	167
TA4	167
TA5	167
TA6	167
TA8	167
TA9	167
TA10	167
TA11	167
TA13	167
TA17	167
TA18	167
TA19	167
TA20	167
TA21	167
TA22	167
TA23	167
TA24	167
TA25	167
TA26	167
TA 7	167
TA 15	167
TA 16	167
TA 193.00 B	29
TA 194.00 B	30
TA 194.00 B 1/2	30
TA 194.15 B	30
TA 194.15 B 1/2	30
TA 194.25 B	30
TA 194.25 B 1/2	30
TA 194.45 B	30
TA 194.45 B 1/2	30
TA 500-1.6M	93
TA 500-1.6M 1/2	93
TA 500-1.6MB	94
TA 500-1.6MB1/2	94
TA 500-2 M 1/2	93
TA 500-2 MB 1/2	94
TA 500-2.5M	93
TA 500-2.5M 1/2	93
TA 500-2.5MB	94
TA 500-2.5MB1/2	94
TA 500-2.8M	93
TA 500-2.8M 1/2	93
TA 500-2.8MB	94
TA 500-2.8MB1/2	94
TA 500-2M	93
TA 500-2MB	94
TA 500-3.2M	93
TA 500-3.2M 1/2	93
TA 500-3.2MB	94
TA 500-3.2MB1/2	94
TA 500-3.6M	93
TA 500-3.6M 1/2	93
TA 500-3.6MB	94
TA 500-3.6MB1/2	94
TA 500-4 M 1/2	93
TA 500-4 MB	94
TA 500-4 MB 1/2	94
TA 500-4.8M	93
TA 500-4.8M 1/2	93
TA 500-4.8MB	94
TA 500-4.8MB1/2	94
TA 500-4M	93

TA 500-5.5M	93
TA 500-5.5M 1/2	93
TA 500-5.5MB	94
TA 500-5.5MB1/2	94
TA 500-6.4M	93
TA 500-6.4M 1/2	93
TA 500-6.4MB	94
TA 500-6.4MB1/2	94
TA 500-8.0M	93
TA 500-8.0M 1/2	93
TA 500-8.0MB	94
TA 500-8.0MB1/2	94
TA 700-1.6 M	95
TA 700-1.6 MB	94
TA 700-1.6M 1/2	95
TA 700-1.6MB1/2	94
TA 700-2 M	95
TA 700-2 M 1/2	95
TA 700-2 MB	94
TA 700-2 MB 1/2	94
TA 700-2.5 M	95
TA 700-2.5 MB	94
TA 700-2.5M 1/2	95
TA 700-2.5MB1/2	94
TA 700-2.8 M	95
TA 700-2.8 M 1/2	95
TA 700-2.8 MB	94
TA 700-2.8MB1/2	94
TA 700-3.2 M	95
TA 700-3.2 MB	94
TA 700-3.2M 1/2	95
TA 700-3.2MB1/2	94
TA 700-3.6 M	95
TA 700-3.6 MB	94
TA 700-3.6M 1/2	95
TA 700-3.6MB1/2	94
TA 700-4 M	95
TA 700-4 M 1/2	95
TA 700-4 MB	94
TA 700-4 MB 1/2	94
TA 700-4.8 M	95
TA 700-4.8 MB	94
TA 700-4.8M 1/2	95
TA 700-4.8MB1/2	94
TA 700-5.5 M	95
TA 700-5.5 MB	94
TA 700-5.5MB1/2	94
TA 700-6.4 M	95
TA 700-6.4 MB	94
TA 700-6.4M 1/2	95
TA 700-6.4MB1/2	94
TA 700-8.0 M	95
TA 700-8.0 MB	94
TA 700-8.0M 1/2	95
TA 700-8.0MB1/2	94
TA 900-1.2 M	25
TA 900-1.2 MB	25
TA 900-1.6 M	25
TA 900-1.6 MB	25
TACC-120	135
TAFJ 60 1/2	84
TAFJ 90 B 1/2	84
TAG 01 B 1/2	86
TAG 02 B 1/2	86
TAGC 01	86
TAGC 02	86
TAHB50	127
TATC-100	149
TB2	166
TB3	166
TB4	166
TB5	166
TB6	166
TB7	166

TB8	166
TB9	166
TB10	166
TB11	166
TB12	166
TB13	166
TB14	166
TB15	166
TB16	166
TB17	166
TB18	166
TB19	166
TB20	166
TB21	166
TB19149	36
TB 606 B	54
TB 606 B 1/2	54
TB 608 B 1/2	54
TBB 4	47
TBB 4 1/2	47
TBB 8	47
TBB 8 1/2	47
TBD 4	48
TBD 4 1/2	48
TBD 8 1/2	48
TBD 22	32
TBD 30	33
TBDX 22	32
TBDX 30	33
TBE 416 1/2	43
TBE 420 1/2	43
TBE 424 1/2	43
TBF 4	47
TBF 4 1/2	47
TBF 8	47
TBF 8 1/2	47
TBM 33 B 1/2	68
TBN 2 B	63
TBN 2 B 1/2	63
TBN 3 B	63
TBN 3 B 1/2	63
TBN 4 1/2	63
TBN 4 B	63
TBN 4 B 1/2	63
TBN 4.5 MB 1/2	63
TBN 5 MB 1/2	63
TBN 6 B	63
TBN 6 B 1/2	63
TBN 8 B 1/2	63
TBN 10 B 1/2	63
TBN 12 B 1/2	63
TBN 15 B 1/2	63
TBN 32 MB 1/2	63
TBO 30 B	55
TBO 30 B 1/2	55
TBO 35 B	55
TBO 35 B 1/2	55
TBO 50 B 1/2	55
TBP3M	132
TBP4M	132
TBP5M	132
TBP6M	132
TBP7M	132
TBP8M	132
TBP9M	132
TBPI0M	132
TBPI1M	132
TBPI2M	132
TBPI3M	132
TBP-5KIT	132
TBR 608 B	54
TBR 608 B 1/2	54
TBR 616 B 1/2	54
TBRS 40	117

TBRS 41	117
TBRS 42	117
TBRS 43	117
TBS 1	62
TBS 2	62
TBS 3	62
TBS 4	62
TBS 5	62
TBS 6	62
TBS 7	62
TBS 8	62
TBS 9	62
TBT 19	166
TBT 20	166
TBT 21	166
TBT 22	166
TBUD-12	103
TBW 4	47
TBW 4 1/2	47
TBW 8	47
TBW 8 1/2	47
TBX 604 1/2	49
TBX 606 1/2	49
TC 1	167
TC 2	167
TC 3	167
TC 4	167
TC 6	46
TC 6 1/2	46
TC 8 B	58
TC 8 B 1/2	58
TC 10	46
TC 10 1/2	46
TC 12 1/2	46
TC 12 B	58
TC 12 B 1/2	58
TC 16 1/2	46
TC 16 B 1/2	58
TC 708 B	56
TC 708 B 1/2	56
TC 712 B	56
TC 712 B 1/2	56
TC 716 B 1/2	56
TCB 50 B 1/2	71
TCB 60 B 1/2	71
TCB 500 B 1/2	71
TCB 600 B 1/2	71
TCM 2	167
TCM 3	167
TCM 4	167
TCO 1B	64
TCO 1B 1/2	64
TCR 8 B	57
TCR 8 B 1/2	57
TCR 12 B	57
TCR 12 B 1/2	57
TCR 16 B 1/2	57
TCRA 16 B	58
TCRA 16 B 1/2	58
TCRA 32 B 1/2	58
TCRR 3 B	45
TCRR 5 B 1/2	45
TCRX 8 1/2	49
TCRX 12 1/2	49
TCW 1 B 1/2	88
TCW 2 B 1/2	88
TCW 3	88
TD 706 1/2	50
TD 706 B 1/2	50
TD 712 B 1/2	50
TD 716 1/2	50
TDA 194-3 MB1/2	69
TDA 194-5 MB1/2	69
TDA 194-8 MB1/2	69

TDA 194.00 B	30
TDA 194.00 B1/2	30
TDA 194.15 B	30
TDA 194.15 B1/2	30
TDA 194.25 B	30
TDA 194.25B1/2	30
TDA 194.45 B	30
TDA 194.45B 1/2	30
TDC 16 1/2	37
TDC 20 1/2	37
TDC 24 1/2	37
TDC 706 B	57
TDC 706 B 1/2	57
TDC 708 B 1/2	57
TDL 3 B	64
TDL 3 B 1/2	64
TDL 4 B	64
TDL 4 B 1/2	64
TDL 6 B	64
TDL 6 B 1/2	64
TDO 8 B	66
TDO 8 B 1/2	66
TDO 12 B 1/2	66
TDO 16 B 1/2	66
TDP 20	37
TDP 20 1/2	37
TDP 35 1/2	37
TDR 33 B 1/2	82
TDSG 44 B	37
TDSG 44 B 1/2	37
TE 808 1/2	89
TE 812 1/2	89
TEB 01 B 1/2	52
TEB 02 B 1/2	52
TEB 03 B 1/2	52
TEB 04 B 1/2	52
TEB 09 B 1/2	51
TEB 10 B 1/2	51
TEB 11 B 1/2	51
TEB 12 B 1/2	51
TEB 14 B 1/2	68
TEB 15 B 1/2	69
TEB 16 B 1/2	69
TEF 01 B 1/2	55
TEG 15	34
TEG 15 LH	34
TEGU5	158
TEGU10	158
TEGUK	158
TEGUK 1	158
TEGUK 2	158
TEGUK 3	158
TEGUK 4	158
TEGUK 5	158
TEGUK 6	158
TEGUK 7	158
TF 7506	44
TF 7506 1/2	44
TF 7509	44
TF 7509 1/2	44
TFG 60	84
TFJE 90	84
TFJS 90	84
TFM 01 B 1/2	77
TFM 03 B 1/2	77
TFM 06 B 1/2	78
TFM 12 B 1/2	78
TFM 18 B 1/2	78
TFM 24 B 1/2	79
TFM 30 B 1/2	79
TFM 32 B 1/2	79
TFM 36 B 1/2	80
TFM 42 B 1/2	80
TFM 48 B 1/2	80

TFM 54 B 1/2	81
TFM 60 B 1/2	81
TFM 66 B 1/2	81
TFM 72 B 1/2	82
TFM 80 B 1/2	82
TFRNA 8	22
TFRNA 12	22
TFRNA 16	22
TFRNA 20	22
TFRNA 24	22
TG 8	14
TG 8 E/C	14
TG 8 P	14
TG 12 3/8	14
TG 12 3/8 E/C	14
TG 12 3/8 P	14
TG 16 1/2	14
TG 16 1/2 E/C	14
TG 16 1/2 P	14
TGA 100 1/2	84
TGAD 12	35
TGAS 12	35
TGB 50	85
TGB 50 1/2	85
TGB 100 1/2	85
TGB 200 1/2	85
TGBD 16 1/2	35
TGBS 16 1/2	35
TGC 100 1/2	86
TGD 35 1/2	85
TGHD 12	35
TGHS 12	35
TH 20 1/2	128
TH 25 1/2	128
TH 25 3/8	128
TH 30 1/2	128
TH 32 1/2	128
TH 35 1/2	128
TH 35 3/8	128
TH 40 1/2	128
TH 50 1/2	128
THBN 45 B 1/2	65
THBN 60 B 1/2	65
THBN 75 B 1/2	65
THC 45 1/2	43
THC 75 1/2	43
THR 40 B 1/2	65
THR 50 B 1/2	64
THR 60 B 1/2	65
THS 12	38
THS 16	38
THS 16 1/2	38
TI 916 B 1/2	61
TK1	166
TK3	166
TK4	166
TK5	166
TK6	166
TK 2	166
TL 70	36
TL 80	36
TL 90 1/2	36
TL 100 1/2	36
TL 120	36
TL 140	36
TL 150 1/2	36
TL 160 1/2	36
TLE 24	33
TLE 24 LH	33
TLM 10	21
TLM 12	21
TLM 12 UNF	21
TLM 13 UNF	21
TLM 14	21

TLM 14 UNF	21
TLM 16	21
TLM 16 UNF	21
TML 60 1/2	86
TO 8012 B	27
TOG 57 1/2	89
TOG 57 B 1/2	89
TOG 67 B 1/2	89
TPD 1 B 1/2	87
TPD 2 1/2	87
TPD 3 1/2	90
TPD 3 B 1/2	90
TPD 4 1/2	90
TPD 4 B 1/2	90
TPD 5 1/2	91
TPD 5 B 1/2	91
TPD 6 1/2	91
TPD 6 B 1/2	91
TPD 25	89
TPD 25 1/2	89
TPD 50	89
TPD 50 1/2	89
TPDC 10	87
TPDC 11	87
TPDC 12	87
TPDC 13	87
TPDR 10 B 1/2	87
TPDR 11 B 1/2	87
TPDR 12 B 1/2	87
TPDR 13 B 1/2	87
TPDS 10 B 1/2	87
TPDS 11 B 1/2	87
TPDS 12 B 1/2	87
TPDS 13 B 1/2	87
TPDV 3 1/2	91
TPDV 4 1/2	92
TPDV 5 1/2	92
TPDV 6 1/2	92
TPS 8 1/2-2	88
TPS 8 B 1/2-1	88
TPS 8 B-1	88
TPS 8-2	88
TPSG 8	88
TR 7506	44
TR 7506 1/2	44
TR 7509	44
TR 7509 1/2	44
TRBS 1	96
TRBS 20 1/4	96
TRBS 30 1/2	96
TRD 3 B 1/2	70
TRM 3 B 1/2	70
TRN 416 1/2	42
TRN 420 1/2	42
TRN 424 1/2	42
TRO 01 1/2	137
TRO 02 1/2	137
TRO 03 1/2	137
TROL 01 1/2	137
TROL 02 1/2	137
TROL 03 1/2	137
TRP 40 B 1/2	90
TRR 10 B 1/2	63
TRR 16 B 1/2	63
TRS 3 B 1/2	70
TRS 7506 1/2	45
TRS 7509 1/2	45
TS 5705 B	68
TS 5705 B 1/2	68
TS 5708 B 1/2	68
TS 5712 B 1/2	68
TS 8012 B	26
TS 8012 BB	27
TS 8016 B	26

TS 8016 BB	27
TSA 28 1/2	38
TSA 30 1/2	38
TSA 30.6 1/2	38
TSB 33 B 1/2	83
TSF 8	7
TSF 12 3/8	7
TSFHH08	7
TSFHH12 3/8	7
TSH 1424	19
TSH 8024 B 1/2	26
TSH 8224 B 1/2	28
TSHX 1424	19
TSHX 8024 B 1/2	26
TSHX 8224 B 1/2	28
TSL 8	8
TSL 12 3/8	8
TSL 16 1/2	8
TSLCB 12 3/8	9
TSLCB 16 M	9
TSLR 12 3/8	8
TSLR 16 1/2	8
TSLR 16 M	8
TSLW 4	10
TSLW 5	10
TSLW 6	10
TSLW 8	10
TSLW 8 M	10
TSLW 10 1/2	10
TSLW 10 5/16	10
TSLW 10 M	10
TSLW 12 1/2	10
TSLW 12 3/8	10
TSLW 12 BB 3/8	28
TSLW 12 M	10
TSLW 16 1/2	10
TSLW 16 BB 1/2	28
TSLW 16 M	10
TSLW 20 M	10
TSM 1408 M	20
TSM 1409.5 M	20
TSM 1413 M	20
TSP08 SH	6
TSP 04 MS	7
TSP 04 S	7
TSP 06 MS	7
TSP 06 S	7
TSP 08 S	7
TSPER08 S	6
TSPL 02 MS	6
TSPL 03 MS	6
TSPL 04 MS	6
TSPL 04 S	6
TSPL 06 S	6
TSPL 08 S	6
TSPR 02 MS	6
TSPR 03 MS	6
TSPR 04 MS	6
TSPR 04 S	6
TSPR 06 S	6
TSPR 08 S	6
TSR 8	8
TSR 12 3/8	8
TSR 16 1/2	8
TSR 33 B 1/2	83
TSRCB 12 3/8	9
TSRCB 16 M	9
TSRM 10 M	11
TSRM 12 3/8	11
TSRM 12 M	11
TSRM 16 1/2	11
TSRM 16 M	11
TSRM 20 M	11
TSRR 8	8

TSRR 8 M	8
TSRR 10 M	8
TSRR 12 3/8	8
TSRR 12 M	8
TSRR 16 1/2	8
TSRR 16 M	8
TSRR 20 M	8
TSRW 4	10
TSRW 5	10
TSRW 6	10
TSRW 8	10
TSRW 8 M	10
TSRW 10 1/2	10
TSRW 10 5/16	10
TSRW 10 M	10
TSRW 12 1/2	10
TSRW 12 3/8	10
TSRW 12 BB 3/8	28
TSRW 12 M	10
TSRW 16 1/2	10
TSRW 16 BB 1/2	28
TSRW 16 M	10
TSRW 20 M	10
TSRWB 8	11
TSRWB 12 3/8	11
TSRWB 16 1/2	11
TSS 1 B 1/2	72
TSS 2	72
TSS 2 1/2	72
TSS 3 B	72
TSS 3 B 1/2	72
TSS 4 B 1/2	73
TSS 5 B 1/2	73
TSS 6 B 1/2	73
TSS 7 B 1/2	74
TSS 8 B 1/2	74
TSS 9 B 1/2	74
TSS 10 B 1/2	74
TSS 11 B 1/2	74
TSS 12 B 1/2	74
TSS 13 1/2	75
TSS 14 B 1/2	75
TSS 15 B 1/2	75
TSS 16 1/2	76
TSS 17 1/2	76
TSS 18 B 1/2	76
TSS 19 B 1/2	77
TSS 21 B 1/2	74
TSS 22 B 1/2	74
TSS 31 B 1/2	74
TSS 32 B 1/2	74
TSSRW 8	10
TST 1409.5 M	22
TST 1413 M	22
TSTX 1413 M	22
TT 606 B 1/2	54
TT 608 B 1/2	54
TTC 8	46
TTC 8 1/2	46
TTC 8 B	59
TTC 8 B 1/2	59
TTC 12	46
TTC 12 1/2	46
TTC 12 B	59
TTC 12 B 1/2	59
TTC 16 1/2	46
TTC 16 B	59
TTC 16 B 1/2	59
TTC 706 B 1/2	57
TTC 708 B 1/2	57
TTCR 4 B	46
TTCR 6 B 1/2	46
TTG 10 1/2	85
TTGC 10	85

TTGR 10	85
TTGS 10	85
TTGW 10	85
TTSLW 4	10
TTSLW 5	10
TTSLW 6	10
TTSLW 8	10
TTSLW 8 M	10
TTSLW 10 1/2	10
TTSLW 10 5/16	10
TTSLW 10 M	10
TTSLW 12 1/2	10
TTSLW 12 3/8	10
TTSLW 12 M	10
TTSLW 16 1/2	10
TTSLW 16 M	10
TTSLW 20 M	10
TTSRW 4	10
TTSRW 5	10
TTSRW 6	10
TTSRW 8	10
TTSRW 8 M	10
TTSRW 10 1/2	10
TTSRW 10 5/16	10
TTSRW 10 M	10
TTSRW 12 1/2	10
TTSRW 12 3/8	10
TTSRW 12 M	10
TTSRW 16 1/2	10
TTSRW 16 M	10
TTSRW 16 M	10
TTSRW 20 M	10
TTSSRW 8	10
TTXSLW 8	10
TTXSLW 16 1/2	10
TTXSRW 8	10
TTXSRW 16 1/2	10
TTXSLW 16 1/2	10
TTXSRW 16 1/2	10
TV148	165
TV149	165
TV 1232	40
TV 1232 1/2	40
TV 1264 1/2	40
TV 1532	41
TV 1532 1/2	41
TV 1564 1/2	41
TV 2208	39
TV 2216 1/2	39
TV 3008	39
TV 3016 1/2	39
TV 4508	39
TV 4516 1/2	39
TVCP	165
TVFLEX	165
TW 7506	45
TW 7506 1/2	45
TW 7509	45
TW 7509 1/2	45
TWCH 40 1/2	129
TWCH 50 1/2	129
TWCH 60 1/2	129
TWJ 16 1/2	87
TX 206 M	16
TX 208	16
TX 208 M	17
TX 210 M	17
TX 212	17
TX 213 M	17
TX 216	17
TX 216 M	17
TX 218 M	17
TX 220	17
TX 506	48
TX 508	48

TX 508 1/2	48
TX 508 B 1/2	48
TX 512 1/2	48
TX 512 B 1/2	48
TX 516 1/2	48
TX 516 B 1/2	48
TX 520 1/2	48
TX 524 1/2	48
TX 700-4.8 M	95
TX 700-5.5 M	95
TX 700-6.4 M	95
TX 700-8 M	95
TX 1412 M	18
TX 1413 M	18
TX 1416	18
TX 1416 M	18
TX 1418 M	18
TX 1419 M	18
TX 1420	18
TX 1424	18
TX 1712 B 1/2	62
TX 2622	33
TX 8016 B 1/2	26
TX 8016 BB 1/2	27
TX 8028 B 1/2	26
TX 8028 BB 1/2	27
TX 8122 B 1/2	60
TX 8165 B 1/2	61
TX 8180 B 1/2	61
TX 8224 B 1/2	28
TXA700-4.8MBI/2	94
TXA700-5.5MBI/2	94
TXA700-6.4MBI/2	94
TXA 700-4.8M1/2	95
TXA 700-5.5M1/2	95
TXA 700-6.4M1/2	95
TXA 700-8 M 1/2	95
TXA 700-8 MBI/2	94
TXSL 8	8
TXSLCB 16 1/2	9
TXSLW 8	10
TXSLW 16 1/2	10
TXSLW 16 BB 1/2	28
TXSPL 08 S	6
TXSPR 08 S	6
TXSR 8	8
TXSRCB 16 1/2	9
TXSRW 8	10
TXSRW 16 1/2	10
TXSRW 16 BB 1/2	28
TXX 208	16
TXX 8016 B 1/2	26
TXX 8016 BB 1/2	27
TXXSLW 16 1/2	28
TXXSLW 16 BB 1/2	28
TXXSRW 16 1/2	10
TXXSRW 16 BB 1/2	28
WD3L56	127
WD3L70	127
WD3R56	126
WD3R70	126
WD4L56	127
WD4L70	127
WD4R56	126
WD4R70	126
WD5L56	127
WD5L70	127
WD5R56	126
WD5R70	126
WD6.5L56	127
WD6.5L70	127
WD6.5R56	126
WD6.5R70	126
WD6L56	127

WD6L70	127
WD6R56	126
WD6R70	126
WD8L56	127
WD8L70	127
WD8R56	126
WD8R70	126
WD9.5L56	127
WD9.5L70	127
WD9.5R56	126
WD9.5R70	126
WD9L56	127
WD9L70	127
WD9R56	126
WD9R70	126
WD10L56	127
WD10L70	127
WD10R56	126
WD10R70	126
WD11L56	127
WD11L70	127
WD11R56	126
WD11R70	126
WD12L56	127
WD12L70	127
WD12R56	126
WD12R70	126
WD15L56	127
WD15L70	127
WD15R56	126
WD15R70	126
WD20R56	128
WD25L56	128
WD25R56	128
WD25R70	128
WD30L56	128
WD30L70	128
WD30R56	128
WD30R70	128
WD35L56	128
WD35L70	128
WD35R56	128
WD35R70	128
WDT5L70	126
WDT5R70	126
WDT8L70	126
WDT8R70	126



Terms & Conditions of Sale

1. General

In these conditions of sale:

"the seller" means Sutton Tools Pty. Ltd. (A.B.N. 12 004 175 731)

"the buyer" means the person or company placing an order with the seller for the purchase of goods/services.

"the goods/services" means the goods/services supplied by the seller under its contract with the buyer.

2. Payment

- 2.1 The purchase price in relation to goods/services shall be payable net within 30 days from the end of the month in which the goods/services were dispatched by the seller to the buyer, unless other terms of payment are expressly stated in writing and signed by the seller.
- 2.2 Should the buyer fail to pay any amount to the seller when it is due, in respect to any order, the seller in addition to any other rights it may have, shall be entitled to suspend further deliveries in respect to any order.

3. Rights in relation to goods/services

- 3.1 The property in the goods/services shall not pass to the buyer until payment in full on any account whatsoever has been received by the seller, and the buyer's payment has been honoured.
- 3.2 If the buyer fails to honour any of these Terms & Conditions of Sale, the seller, without notice shall have the right to take possession of the goods/services and/or recover the full amount owing to the seller together with interest and costs.
- 3.3 The buyer shall hold the goods/services supplied by the seller in such a way as to identify them as being goods/services in which the property has not passed to the buyer pending payment in full.
- 3.4 Until payment of all debts owing to the seller (some which may not necessarily be due for payment), the seller has the right to retake and resume possession of any of the goods/services, should an arrangement under Part X of the Bankruptcy Act 1966 be invoked against the buyer, or the buyer is placed into receivership/liquidation or wound up.

4. General condition of sale

- 4.1 Delivery Free into store, to Sutton Tools Distributors, in pack quantities as detailed in the price list.
- 4.2 Delivery FIS for orders greater than \$30 via Australia Post or greater than \$200 via Air Freight. Otherwise a service and handling fee will apply.
- 4.3 Goods sent direct to end users: a surcharge of \$25.00 will apply to consignments less than 5 kilo's, above 5 kilo's – price on application. If applicable, GST of 10% will be charged.
- 4.4 All prices shown are in AUSTRALIAN DOLLARS.
- 4.5 Priced items are stockable; items outside this range are made to special order only. The prices set out and referred to herein are recommended prices only and there is no obligation to comply with the recommendation.

5. Claims and defects

- 5.1 Claims due to customer ordering errors will be subject to a restocking charge of 15% and must be returned in a saleable condition – unmarked, unopened, pristine condition to current specifications. Sutton Tools' sales department should be contacted prior to any goods being returned. Any goods being returned should be freighted at Customer / Buyer cost.
- 5.2 Claims must be reported without delay upon discovery of the same and in any event not later than 7 working days following delivery.
- 5.3 Where complaints in respect to defects or warranted goods are justified our liability is limited solely to the obligation to take back the goods and to replace them free of charge.
- 5.4 The company reserves the right to adopt without prior notice, standards and dimensions other than those set forth herein.

Disclaimer: Whilst every effort has been made to ensure that the information is accurate, Sutton Tools reserve the right to correct any errors, inaccuracies or omissions and to change or update information at any time without prior notice.



Carbitool is a division of Sutton Tools Pty. Ltd. ABN. 12 004 175 731

Head Office

12 Levanswell Road, Moorabbin 3189, Victoria, Australia

T +61 3 9555 2966 **F** +61 3 9555 8695 **E** sales@carbitool.com.au

www.carbitool.com.au



499980530_0919